

OPERATING INSTRUCTIONS

SORVALL[®] RT6000B & T6000B TABLETOP CENTRIFUGES

**Du Pont Company
SORVALL[®] Products
Wilmington, Delaware 19898
U.S.A.**

SORVALL[®] Centrifuges



This manual is a guide to the use of the

SORVALL® RT6000B and T6000B Tabletop Centrifuges

Data herein has been verified and validated and is believed adequate for the intended use of the centrifuge. Because failure to follow the recommendations set forth in this manual could produce personal injury or property damage, always follow the recommendations set forth herein. Du Pont does not guarantee results and assumes no obligation for the performance of rotors or other products that are not used in accordance with the instructions provided. This publication is not a license to operate under, nor a recommendation to infringe upon, any process patents.

Publications prior to the Issue Date of this manual may contain data in apparent conflict with that provided herein. Please consider all data in this manual to be the most current.

NOTES, CAUTIONS, and WARNINGS within the text of this manual are used to emphasize important and critical instructions.

WARNING: A Warning informs the operator of a hazard or an unsafe practice that could result in personal injury, affect the operator's health, or contaminate the environment.

CAUTION: A Caution informs the operator of an unsafe practice that could result in damage of equipment.

NOTE: A Note highlights essential information.

Important Safety Information

Certain potentially dangerous conditions are inherent to the use of all centrifuges. To ensure safe operation of this centrifuge, anyone using it should be aware of all safe practices and take all precautions described below and throughout this manual.

WARNING

When using radioactive, toxic, or pathogenic materials, be aware of all characteristics of the materials and the hazards associated with them in the event leakage occurs during centrifugation. If leakage does occur, neither the centrifuge nor the rotor can protect you from particles dispersed in the air. To protect yourself, we recommend additional precautions be taken to prevent exposure to these materials, e.g., use of controlled ventilation or isolation areas.

Always be aware of the possibility of contamination when using radioactive, toxic, or pathogenic materials. Take all necessary precautions and use appropriate decontamination procedures if exposure occurs.

The use of sealed rotors, buckets and/or sample containers will provide increased protection from contamination during routine operation. However, these items will not guarantee contamination protection from accidents resulting in damage to the rotor or buckets. Do not run hazardous materials in the centrifuge unless placed in a biohazard enclosure and operated using all appropriate safety precautions.

Never use any material capable of producing flammable or explosive vapors.

Never exceed the maximum rated speed of the installed rotor; to do so can cause rotor failure.

Always reduce (derate) rotor speed as instructed in this manual whenever:

- the rotor speed/temperature combination exceeds the solubility of the gradient material and causes it to precipitate.
- the compartment load exceeds the maximum allowable compartment load specified. See Chapter 3, Operation, page 3-6.

Failure to reduce rotor speed under these conditions can cause rotor failure.

CAUTION

Do not run or precool a rotor at the critical speed, as this will have a detrimental effect on centrifuge component life. See Chapter 3, page 3-3.

Do not operate the centrifuge with a rotor out of balance. To do so can cause damage to the centrifuge drive assembly.

Do not operate centrifuge without a rotor properly installed: rotor cover must be on and locked in place, and the rotor locked to the centrifuge drive. See rotor instruction manual.

The centrifuge can be damaged if connected to the wrong voltage. Check the voltage before plugging the centrifuge into a power source. Du Pont is not responsible for incorrect installation.

Always maintain the centrifuge in the recommended manner. See Chapter 4, Maintenance.

Table of Contents

	Page
Safety Information Page	iii

Chapter 1. DESCRIPTION

Centrifuge Description	1-1
Centrifuge Specifications	1-1
Rotors	1-2

Chapter 2. INSTALLATION

Inspection	2-1
Electrical Requirements	2-1
Installation	2-2

Chapter 3. OPERATION

Controls and Indicators	3-1
Rotor Considerations	3-2
Precooling a Rotor in the RT6000B Centrifuge	3-3
Running Hazardous Material	3-4
Operation	3-4
Emergency Sample Recovery	3-6
Reducing Speed for Rotor Compartment Loads in Excess of Design Mass	3-6

Chapter 4. MAINTENANCE

Inspection and Cleaning	4-1
REV/MIN x 1000 Indicator Adjustment	4-2
Motor Brush Inspection and Replacement	4-3
RT6000B CHAMBER TEMP° C Indicator Adjustment	4-4
Parts Ordering Information	4-4
Service Decontamination Policy	4-5

APPENDIX

Warranty
Index
Decontamination Certificates

List of Illustrations

Figure		Page
3-1.	Controls and Indicators	3-1
3-2.	Location of Mechanical Override Loop	3-6
4-1.	REV/MIN x 1000 Indicator Adjustment	4-3
4-2.	Motor Brush Assembly	4-4
4-3.	CHAMBER TEMP° C Indicator Adjustment	4-4

List of Tables

Table		Page
3-1.	Controls and Indicators	3-1

A PHOTOGRAPH OF THIS INSTRUMENT WAS NOT TAKEN AND THEREFORE
WILL NOT BE AVAILABLE FOR FIRST PRINTING OF MANUAL

*Figure 1-1. SORVALL® RT6000B Refrigerated
Tabletop Centrifuge (T6000B not shown)*

Chapter 1 DESCRIPTION

This manual provides you with the information you need to install, operate and maintain your SORVALL® RT6000B and T6000B Tabletop Centrifuges. If you encounter any problem concerning either operation or maintenance that is not covered in this manual, please contact our Marketing Technical Group for assistance. In the United States, telephone toll free (800) 551-2121. Outside the United States, contact your local distributor or agent for SORVALL® Products.

Centrifuge Description

The RT6000B combines the features of the tabletop centrifuge and those of the larger refrigerated centrifuge in a compact tabletop instrument. It is similar to other SORVALL® Tabletop Centrifuges, with an added refrigeration system that consists of an evaporator/rotor chamber and a low-temperature condensing unit. The system is designed to maintain temperature within 1°C, while in the operating range of -5°C to +25°C. The T6000B is a non-refrigerated tabletop centrifuge.

Both the RT6000B and T6000B feature a closed-loop speed control and have a see-through chamber door that allows rotor calibration and visual inspection of a run in progress. The chamber door is counterbalanced for easy opening and safe closing. The lid latch is locked manually by turning the door release knob counterclockwise to the LOCKED position, then mechanically an interlock engages when the rotor begins spinning to prevent the chamber door from being opened during operation. The gyro-action, self-centering drive has a diamond hex-shaped drive spindle which assures proper seating of rotors. The centrifuges also have a slow-start feature that slowly accelerates the rotor from 0 to 600rpm.*

Centrifuge Specifications

Maximum Speed** 6000 rpm

Operating Temperature

Range (RT6000B only) -5°C to +25°C

Maximum heat output during

operation 6000 Btu per hour (RT6000B)
 3000 Btu per hour (T6000B)

(continued)

*Speed in revolutions per minute (rpm) is related to angular velocity, ω , according to the following:

$$\omega = (\text{rpm}) \left(\frac{2\pi}{60} \right) = (\text{rpm}) (0.10472)$$

Where ω = rad/s. All further references in this manual to speed will be designated as rpm.

** Maximum speed is dependent on rotor and line voltage.

Centrifuge Specifications (continued)

Electrical Requirements:

RT6000B	115 Vac, 60 Hz, 15A, single phase*
	220 Vac, 50 Hz, 8A, single phase*
T6000B.....	115 Vac, 60 Hz, 8A, single phase
	220 Vac, 50 Hz, 4A, single phase

Dimensions:

Width (RT6000B)	81 cm (32 inches)
(T6000B)	66 cm (26 inches)
Depth	64 cm (25 inches)
Height.....	32 cm (12.5 inches)

Mass (Weight):

RT6000B	85 kg (187 lbs)
T6000B.....	78 kg (160 lbs)

*CSA and UL Certified.

Rotors

The table below lists the rotors available for the RT6000B and T6000B Centrifuges. For more information about other rotor accessories and tubes refer to the most current SORVALL® Rotors, Tubes, Bottles, and Adapters Catalog.

Rotor Specifications

Rotor	Maximum Operating Speed (rpm)	Maximum Compartment Mass (grams)	Maximum Relative Centrifugal Force (RCF)
A-384 Fixed-Angle Rotor	6000	27 ¹	4890
A-500 Fixed-Angle Rotor	6000	115 ¹	4960
H-1000B Swinging Bucket Rotor	3200	820 ²	2190
A/S-400 Fixed-Angle Rotor	4380	90 ²	3000

1 Includes weight of tube holder, tube or bottle, adapter, and tube contents.

2 Includes weight of adapter, tube or bottle, and tube contents.

RT-6000B

Centrifuge Specifications

Maximum Speed** 6000 rpm

Operating Temperature

Range (RT6000B only) -5°C to +25°C

Maximum heat output during

operation 6000 Btu per hour (RT6000B)
 3000 Btu per hour (T6000B)

Electrical Requirements:

RT6000B 115 Vac, 60 Hz, 15A, single phase*
 220 Vac, 50 Hz, 8A, single phase*
 T6000B..... 115 Vac, 60 Hz, 8A, single phase
 220 Vac, 50 Hz, 4A, single phase

Dimensions:

Width (RT6000B) 81 cm (32 inches)
 (T6000B) 66 cm (26 inches)
 Depth 64 cm (25 inches)
 Height..... 32 cm (12.5 inches)

Mass (Weight):

RT6000B 85 kg (187 lbs)
 T6000B..... 78 kg (160 lbs)

Rotor Specifications

Rotor	Maximum Operating Speed (rpm)	Maximum Compartment Mass (grams)	Maximum Relative Centrifugal Force (RCF)
A-384 Fixed-Angle Rotor	6000	27 ¹	4890
A-500 Fixed-Angle Rotor	6000	115 ¹	4960
H-1000B Swinging Bucket Rotor	3200	820 ²	2190
A/S-400 Fixed-Angle Rotor	4380	90 ²	3000

Chapter 2

INSTALLATION

This chapter contains instructions to prepare your SORVALL® RT6000B and T6000B for operation.

Inspection

When you receive your centrifuge, carefully inspect it for any signs of shipping damage. If you find damage, report it immediately to the transportation company and file a damage claim, then notify Du Pont.

Check the parts received with the centrifuge against the shipping list; if any parts are missing, contact Du Pont (see back cover).

WARNING

The RT6000B weighs 187 lbs. and the T6000B weighs 160 lbs. Refer to the unpacking instructions for proper care when lifting and installing the centrifuge. Failure to use proper lifting techniques can result in possible damage to the centrifuge and/or personal injury.

CAUTION

Do not lift the centrifuge by the front panel or by the lid. To do so can result in damage to these parts.

Do not place the RT6000B on its side; any position other than upright can cause compressor contamination.

Electrical Requirements

The centrifuge has specific power requirements and must be connected to the correct supply for proper performance. The nameplate on the back of the cabinet specifies one of the following:

RT6000B: 105-125 Vac, 60 Hz, single phase, 15 amps*
210-230 Vac, 50 Hz, single phase, 8 amps*

T6000B: 105-125 Vac, 60 Hz, single phase, 8 amps
210-230 Vac, 50 Hz, single phase, 4 amps

The current draw during acceleration in the T6000B could peak to 15 amps for 60 Hz centrifuges and 8 amps for 50 Hz centrifuges. Therefore, if the main power source is

*CSA and UL Certified

protected by fuses rather than circuit breakers, we recommend the use of slow-blow or time-delay fuses.

CAUTION

If the power cord is connected to the wrong voltage, it can cause damage to the centrifuge. Check the voltage listed on the nameplate before plugging the power cord into the power source. Du Pont is not responsible for incorrect installation.

The power cord has a universal keyed plug that inserts into the receptacle at the back of the centrifuge. The other end of the power cord has a NEMA5-15P, three-prong molded cap with a ground pin and parallel blades. The plug will fit Hubbell receptacle No. 5261 for 115 volt (parallel blades) or receptacle No. 5561 for 220 volt (tandem blades). The power cord must be attached when the centrifuge is installed.

Installation

To install the centrifuge:

1. Place the centrifuge on a large, sturdy bench or work table that will support its weight leaving space for sample preparation. Be sure to leave a minimum clearance of 5cm(2 inches) on all sides for proper air circulation.
2. Insert the universal keyed end of the power cord into the receptacle at the back of the centrifuge.
3. Make sure the centrifuge is level. If necessary, place the leveling pads provided under the corners of the centrifuge.
4. Make sure the POWER switch is set to "0" (off position), then plug the power cord into a wall receptacle. The centrifuge is now ready for use.

Chapter 3 OPERATION

This chapter describes the function of each operating control and indicator and provides the information necessary to operate your SORVALL® RT6000B and T6000B Centrifuges.

Controls and Indicators

Figure 3-1 shows the location of operating controls and indicators. Table 3-1 lists them by item number and describes their function.

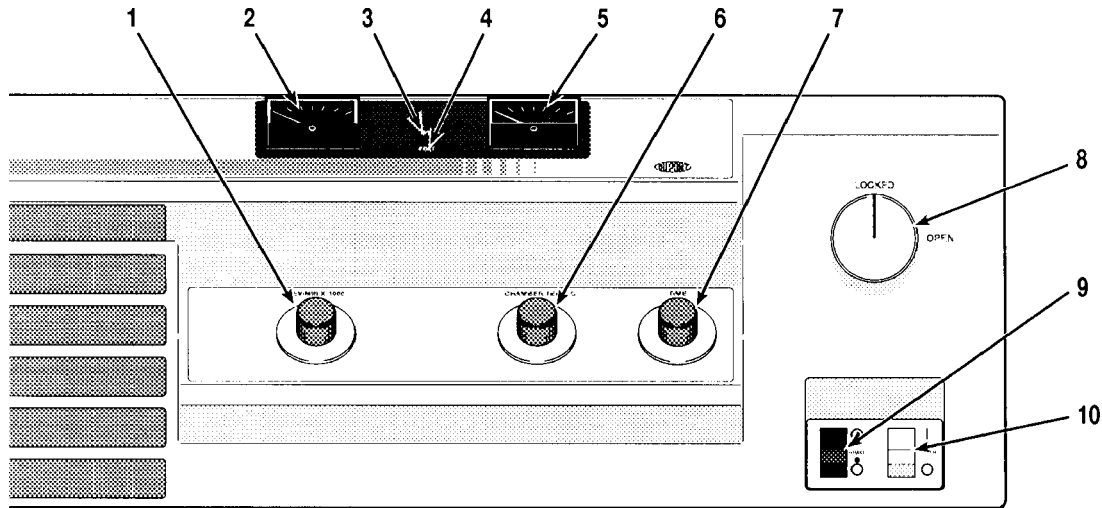

Figure 3-1. Controls and Indicators

Table 3-1. Controls and Indicators
(keyed to figure 3-1)

Item	Name	Function
1	REV/MIN x 1000 dial	Sets desired run speed. At full counterclockwise position the speed control is turned off and the rotor will not spin. (The settings on the dial indicate actual rotor speed.)
<p>CAUTION Continued operation of the centrifuge below 600 rpm may damage the speed control.</p>		

(continued)

**Table 3-1. Controls and Indicators (continued)
(keyed to figure 3-1)**

Item	Name	Function
2	REV/MIN x 1000 indicator	Indicates actual rotor speed from 0 to 6000 rpm \pm 100 rpm.
3	OPEN light*	Lights at the end of the run to indicate that the door may be opened.
4	FAULT light* (T6000B)	Lights when a rotor imbalance occurs or when a drive belt malfunction occurs. Centrifuge will not restart until problem has been corrected.
4	FAULT light* (RT6000B)	Lights when a rotor imbalance occurs, when chamber over or under temperature occurs, or when a drive belt malfunction occurs. The centrifuge will not restart until problem has been corrected.
5	CHAMBER TEMP° C indicator (RT6000B only)	Indicates actual chamber temperature from -20°C to +40°C.
6	CHAMBER TEMP° C dial (RT6000B only)	Sets desired chamber temperature from -20°C to +40°C.
7	TIME dial	Sets length of run time up to 30 minutes (or 35 minutes on 50 Hz instruments). At ∞ , sets indefinite run time. The TIME dial acts as a start switch to begin centrifuge run.
8	Door release knob	When the knob is turned to OPEN it will release the door latches; when knob is turned to LOCKED it engages the door latches.
9	BRAKE switch	When set to "⊙", the centrifuge brakes to approximately 200 rpm at end of run then coasts to a stop. When set to "⊙", the centrifuge coasts to a stop without braking.
10	POWER switch	The power switch is an on/off toggle switch that, when set to "I" applies power to the centrifuge.

*These messages are backlit, meaning that each message lights only when the condition that it represents exists.

Rotor Considerations

a. Rotor Temperature

Any type of centrifugation creates an increase in rotor temperature. The increase in temperature is caused by many variables including ambient temperature, rotor speed, length of the run, and the type of rotor.

Air flow through the T6000B centrifuge is designed to minimize increase in rotor temperature. Air enters through an opening in the center of the lid and exits through the exhaust duct at the top of the rotor chamber.

WARNING

Blocking the air flow entering and/or exiting the T6000B rotor chamber will cause an increase in the temperature within the rotor chamber. The temperature increase can temporarily distort the non-metal surfaces allowing particles to exit the rotor chamber resulting in personal injury and/or centrifuge damage should tube breakage or rotor failure occur.

When running temperature-sensitive material we recommend that you do a trial run.

b. Rotor Installation, Loading and Balancing

Refer to the rotor instruction manual for loading and balancing procedures as well as information regarding the selection and use of tubes, bottles, and adapters.

WARNING

When loading the rotor, be sure not to exceed the maximum compartment mass of the rotor (see Table 1-1 or the individual rotor instruction manual). If maximum compartment mass is exceeded, maximum rotor speed must be lowered as described on page 3-6, Reducing Speed for Rotor Compartment Loads in Excess of Design Mass. Failure to do so can cause rotor failure which could result in personal injury and/or centrifuge damage.

CAUTION

Do not operate the centrifuge without a rotor installed and properly balanced. Also, when installing a rotor carefully place it on the centrifuge drive spindle. The drive can be damaged if rotors are dropped onto it.

Precooling a Rotor in the RT6000B Centrifuge

For operation at temperatures other than ambient, the rotor and rotor chamber should be pre-cooled before the run using either of the precooling methods described.

a. Precooling a Rotor in the Centrifuge

1. Follow steps 1 through 6 of the operating instructions (pages 3-4 and 3-5).
2. Set the REV/MIN x 1000 dial to 1500 rpm.

The length of time it will take to precool a rotor will vary depending on the temperature selected, rotor weight, and rotor material.

b. Precooling the Centrifuge Chamber Only

If the rotor has been precooled outside of the chamber (e.g., in a refrigerator or cold room), the chamber should be precooled before the run.

1. With the chamber door closed, set the CHAMBER TEMP° C dial to the temperature desired.
2. When the chamber is cooled to the proper temperature, install the precooled rotor and begin the centrifuge run.

NOTE

To expedite cooling of the centrifuge chamber, run an empty rotor at 1500 rpm.

Running Hazardous Material

Because neither centrifuge chamber of the RT6000B or T6000B are designed for biocontainment, some vapors or aerosols released from uncapped, leaking or broken tubes may leak from the chamber during operation. Once a run is completed and the chamber door is opened, the vapors or aerosols which have concentrated in the chamber will be released into the laboratory area. For this reason, when materials which are pathogenic, toxic, or otherwise hazardous in nature are to be run, the centrifuge should be placed in a biohazard safety enclosure and operated using all appropriate safety precautions. **Observe the WARNING found on the Safety Information Page.**

Use appropriate decontamination procedures should exposure to any hazardous material occur. See Chapter 4 for the procedure to follow if a centrifuge or rotor that has been used with a hazardous material must be returned to our service facilities for repair.

Operation

To perform the run:

1. Set the POWER switch to "I", and turn the TIME dial off. (The fan will turn on and continue to operate whenever the POWER switch is in the on position).

NOTES

RT6000B Centrifuges ONLY:

The FAULT light may come on when the power is turned on with the door closed. The light will go off when the door is opened.

It is recommended that the chamber door be kept closed when the centrifuge is not in use to prevent condensation from forming in the rotor chamber.

2. When the OPEN light comes on, turn the door release knob to the OPEN position, and lift the chamber door up.
3. Install the rotor on the drive shaft and close the door. Turn the door release knob to the LOCKED position (the door latches will engage).

CAUTION

Be sure the rotor is properly balanced and seated on the drive spindle. See rotor instruction manual.

4. **RT6000B only:** Set the CHAMBER TEMP° C dial to the run temperature desired.
5. Set the BRAKE switch to "⊙" if braking is desired.
6. Set the TIME dial to the run time desired.
7. Set the REV/MIN x 1000 dial to the desired run speed.

NOTE

The settings on the REV/MIN x 1000 dial indicate actual rotor speed. Verify the rotor speed by checking the REV/MIN x 1000 indicator.

A zero speed switch is incorporated in the REV/MIN x 1000 dial. This switch prevents rotation of the rotor if the door is locked and the timer is on.

At the end of the run remove the rotor as described below.

WARNING

Always check that the rotor has stopped spinning *before* opening the chamber door. Do not open the door while the rotor is still in motion; to do so can result in possible injury.

To remove the rotor:

1. Leave the POWER switch set to "I".
2. If the TIME dial is set to ∞, turn it off.
3. When the OPEN light comes on, turn the door release knob to OPEN position and lift the chamber door up.
4. Remove the rotor, close the chamber door, and set the POWER switch to "0".

Emergency Sample Recovery

If the main power shuts off because of a power failure or system malfunction while the rotor is spinning, the chamber door will not open. A mechanical override is provided to allow sample recovery in the case of an emergency.

WARNING

This procedure is included for *emergency sample recovery only* and should never be used for any purpose other than those explained in this section.

When the main power shuts off, the brake will not operate. Wait until the ~~rotor stops spinning before using the mechanical override.~~

The mechanical override loop is located under the right, front corner of the centrifuge as shown in figure 3-2. To operate the override, insert a screwdriver or similar object into the metal loop and pull down. Turn the door release knob to the OPEN position and lift the chamber door up.

Figure 3-2. Location of Mechanical Override Loop

NOTE

Leave a clearance area around the lower right corner of the centrifuge to prevent obstruction of the mechanical override.

Reducing Speed for Rotor Compartment Loads in Excess of Design Mass

There is a maximum allowable compartment mass established for each centrifuge rotor.

To prevent rotor failure, the total contents of any compartment, including specimen, tubes, cover, and adapters (if used), must not exceed the figure given on page 1-2 unless rotor speed is reduced proportionately.

Strict adherence to the maximum allowable compartment mass or reduced speed is required to prevent rotor failure. **Observe WARNING on the Safety Information Page in front of this manual.**

The rotor speed is reduced in proportion to the square of the ratio for the maximum allowable compartment mass to the actual compartment mass (including specimen, tubes, covers, and adapters). If the compartment mass is more than that specified for the rotor, the reduced speed can be determined by using the formula given below—

$$\text{Reduced Rotor Speed} = \text{Maximum Rotor Speed} \times \sqrt{\frac{\text{Maximum Compartment Mass}}{\text{Actual Compartment Mass}}}$$

Chapter 4

MAINTENANCE

This chapter describes routine maintenance procedures that you should perform on a regular basis. As the user, it is your responsibility to make certain that these procedures are followed when necessary. Also, to keep your centrifuge in good working condition and ensure accurate test results, we recommend that, in addition to these routine procedures, you have the speed control, timer, rotor imbalance detector and temperature control checked periodically by a Du Pont Service Representative or other qualified service personnel because occasionally, these controls may need to be recalibrated. If further service is needed, contact your local representative for SORVALL® Products.

WARNING

Because of the high voltages in this centrifuge, only personnel trained in electronics should test or repair the electrical circuits.

If hazardous materials have been processed in the centrifuge, take all necessary precautions when cleaning or servicing the centrifuge to avoid personal exposure to contamination.

Inspection and Cleaning

a. Inspection

Inspect the centrifuge each week for signs of wear, encrusted biological deposits, and general cleanliness. Follow the cleaning procedures described below when necessary.

b. Cleaning

Rotor Chamber

The rotor chamber should be kept clean and wiped dry. Wash the rotor chamber with a mild, nonalkaline dishwashing liquid, then rinse and dry with a soft absorbent cloth.

Use 70% ethanol to disinfect the rotor chamber or a 2% glutaraldehyde solution to sterilize it. For general radioactive decontamination, use a solution of equal parts of 70% ethanol, 10% SDS, and water. Follow this with ethanol rinses then deionized water rinses. Dry with a soft absorbent cloth. Dispose of all wash solutions in proper radioactive waste containers. **Read the CAUTION on the next page.**

CAUTION

Chlorides are extremely harmful to aluminum alloy rotors and can cause stress corrosion cracking. Therefore, if chlorides are used to disinfect the chamber, be sure to rinse the chamber thoroughly with water to remove all of the chloride cleanser.

Periodically defrost the rotor chamber of the RT6000B to maintain efficient cooling. The chamber can be defrosted by either leaving the door open with the power off until the frost melts, or by running a rotor for approximately five minutes at 40°C. When the chamber has been completely defrosted, wipe the chamber dry.

Drive Spindle

Before each run, wipe the spindle with a soft cloth before a rotor is installed to reduce the chance of the rotor sticking to the spindle. To keep the surface of the spindle smooth, polish occasionally with #400 Emery cloth. Always wipe the spindle clean after polishing.

Cabinet

Clean the enameled cabinet panels with a household wax cleaner. Use a mild, nonalkaline detergent and water to clean the centrifuge.

Chamber Door

Clean the chamber door with a soft, wet cloth and soapy water. Avoid using abrasive materials (for example, dry papertowels) and organic solvents (for example, acetone) on the dry surface.

Condenser Fins

To maintain the efficiency of the RT6000B refrigeration system, keep the condenser fins (located in the front of the centrifuge) free of dirt and dust. Clean the fins with a brush or vacuum cleaner at one to three month intervals.

c. FAULT System Check

To check the function of the FAULT system, move the drive spindle back and forth to simulate a rotor imbalance. This should cause the FAULT indicator to light.

REV/MIN x 1000 Indicator Adjustment (figure 4-1)

With the POWER switch set to "0", use a screwdriver and adjust the zero adjustment screw until the pointer reads 0.

Figure 4-1. REV/MIN x 1000 Indicator Adjustment

Motor Brush Inspection and Replacement

1. Unplug the centrifuge power cord.
2. Remove the four screws from the access cover and remove the cover.
3. Remove the plastic brush caps from the motor with a screwdriver, and pull the brushes from their holders, noting orientations.

NOTE

Before inserting the replacement brushes, remove any carbon accumulation from the interior of the brush holder. The brush should then move freely in the brush holder.

- a. If the brushes are longer than 6 mm (1/4 inch), new brushes are not needed. Reinstall brushes in their original brush tubes with the same orientation.
- b. If the brushes are shorter than 6 mm (1/4 inch), replace worn brushes with new brushes, Catalog No. 12732.

NOTE

If this is not the original set of brushes and the brushes are shorter than 6 mm (1/4 inch), periodically (that is, after 3 to 4 brush set changes) have the armature commutator inspected for wear and roughening (pitting) by a qualified technician when the brushes are replaced. If necessary, replace the armature.

4. Reinstall the plastic brush caps, making sure that the brush spring retainer “ears” are seated in the brush holder slots (see figure 4-2).
5. Reinstall the access cover and secure in place using the four screws removed in step 2.
6. With the POWER switch set to "0", plug in the centrifuge power cord.
7. If a new armature and/or new brushes have been installed, run the centrifuge at 1000rpm with a rotor for 30 minutes to seat the brushes. Failure to do this will result

in immediate brush burn and commutator pitting and will severely limit the life of the new parts.

CAUTION

Do not stone or burnish the commutator as this will increase brush wear and may result in smear metal on the surface of the commutator.

Do not allow brushes to wear to the point where they do not make contact with the commutator. This causes severe arcing, resulting in excessive brush and commutator wear.

Figure 4-2. Motor Brush Assembly

CHAMBER TEMP° C Indicator Adjustment (RT6000B only)

With the POWER switch set to "0", use a screwdriver and adjust the adjusting screw until the pointer reads -20°C. (Refer to figure 4-3.)

Figure 4-3. CHAMBER TEMP° C Indicator Adjustment

Parts Ordering Information

To order replacement parts, telephone toll free (800) 551-2121 in the United States. Outside the United States, contact your local distributor or agent for SORVALL® Products. Be sure to provide a description of the part, the centrifuge model and serial number.

Service Decontamination Policy

WARNING

Because of the characteristics of the samples likely to be processed in this centrifuge, biological or radioactive contamination may occur. Always be aware of this possibility, and take normal precautions. Use appropriate decontamination procedures should exposure occur.

If a centrifuge or rotor that has been used with radioactive or pathogenic material requires servicing by Du Pont personnel, either at the customer's laboratory or at a Du Pont facility, comply with the following procedure to ensure the safety of all personnel:

1. Clean the centrifuge or rotor to be serviced of all encrusted material and decontaminate it (see Maintenance Section of the centrifuge or rotor instruction manual) prior to servicing by the Du Pont representative or returning it to the Du Pont facility. There must be no radioactivity detectable by survey equipment.

The SORVALL® Rotors, Tubes, Bottles, Adapters, and Accessories Catalog contains descriptions of commonly used decontamination methods and a chart showing method compatibility with various materials. The centrifuge or rotor instruction manual contains specific guidance about cleaning and decontamination methods appropriate for the product it describes.

Clean and decontaminate your centrifuge or rotor as follows:

For tabletop centrifuges:

- a. Remove rotor from the rotor chamber.
- b. Remove motor sealing gasket and wash with appropriate decontaminant.
- c. Decontaminate cover, bowl, and drive using an appropriate method.

For rotors:

- a. Remove tubes, bottles, and adapters from the rotor and decontaminate rotor using an appropriate method. If tubes or rotor caps are stuck in the rotor, or the rotor lid is stuck, notify Du Pont representative; be prepared with the name and nature of the sample so the Du Pont Chemical Hazards Officer can decide whether to authorize the rotor's return to a Du Pont facility.
2. Complete and attach Decontamination Information Certificate (SORVALL® Instruments Form No. IPDP-59 or E53603) to the centrifuge or rotor before servicing or return to Du Pont facility. If Certificate is not available, attach a written statement verifying decontamination (what was contaminant and what decontamination method was used).

If the centrifuge or rotor must be returned to a Du Pont facility:

1. Contact your Du Pont representative to obtain a Return Service Order Number (RSO#); be prepared with the name and serial number of the centrifuge or rotor and the repairs required.

2. Send item(s) with the RSO# clearly marked on the outside of packaging to the address obtained from your Du Pont representative.

NOTE

United States federal regulations require that parts and instruments *must* be decontaminated before being transported.

If a centrifuge or rotor to be serviced does not have a Decontamination Information Certificate attached and, in Du Pont's opinion presents a potential radioactive or biological hazard, the Du Pont representative will not service the equipment until proper decontamination and certification is complete. If Du Pont receive a centrifuge or rotor at its Service facilities which, in its opinion, is a radioactive or biological hazard, the sender will be contacted for instructions as to disposition of the equipment. Disposition costs will be borne by the sender.

Decontamination Information Certificates are included with these instructions. Additional certificates are available from your local Account Representative or Field Service Engineer. In the event these certificates are not available, a written statement certifying that the unit has been properly decontaminated and outlining the procedures used will be acceptable.

NOTE

The Field Service Engineer will note on the Customer Service Repair Report if decontamination was required and, if so, what the contaminant was and what procedure was used. If no decontamination was required, it will be so stated.

APPENDIX

Warranty

Warranty

E. I. Du Pont de Nemours and Company makes no warranty of any kind, expressed or implied, except as stated in this warranty policy.

The SORVALL® RT6000B and T6000B Tabletop Centrifuges are warranted to be free from defects in material and workmanship for a period of one (1) year from the date of delivery. Du Pont will repair or replace and return free of charge any part which is returned to its factory within said period, transportation prepaid by user, and which is found upon inspection to have been defective in materials or workmanship. This warranty does not apply to any damage to any instrument resulting from: normal wear and tear; misuse; abuse; use of electrical currents or circuits other than those specified on the plate affixed to the instrument; or use of any rotor other than those intended for use in this instrument.

Du Pont reserves the right to change, alter, modify or improve any of its instruments without any obligation whatsoever to make corresponding changes to any instrument previously sold or shipped.

THE FOREGOING OBLIGATIONS ARE IN LIEU OF ALL OTHER OBLIGATIONS AND LIABILITIES INCLUDING NEGLIGENCE AND ALL WARRANTIES, OF MERCHANTABILITY OR OTHERWISE, EXPRESSED OR IMPLIED IN FACT OR BY LAW, AND STATE OUR ENTIRE AND EXCLUSIVE LIABILITY AND BUYER'S EXCLUSIVE REMEDY FOR ANY CLAIM OR DAMAGES IN CONNECTION WITH THE SALE OR FURNISHING OF GOODS OR PARTS, THEIR DESIGN, SUITABILITY FOR USE, INSTALLATION OR OPERATION. DU PONT WILL IN NO EVENT BE LIABLE FOR ANY SPECIAL OR CONSEQUENTIAL DAMAGES WHATSOEVER, AND OUR LIABILITY UNDER NO CIRCUMSTANCES WILL EXCEED THE CONTRACT PRICE FOR THE GOODS FOR WHICH LIABILITY IS CLAIMED.

- Cabinet, Cleaning, 4-2
- Centrifuge Specifications, 1-1
- CHAMBER TEMP°C Indicator
 - Adjustment, RT6000B, 4-4
- Cleaning,
 - Cabinet, 4-2
 - Chamber Door, 4-2
 - Condenser Fins, 4-2
 - Drive Spindle, 4-2
 - Rotor Chamber, 4-1
- Compartment Loads, 3-6
- Condenser Fins, Cleaning, 4-2
- Controls and Indicators, 3-1-3-2
- Decontamination Policy, 4-5
- Dimensions, Centrifuge, 1-2
- Door, Cleaning, 4-2
- Door Opening, Emergency, 3-6
- Electrical Requirements, 1-2, 2-1
- Emergency Sample Recovery, 3-6
- FAULT System Check, 4-2
- Inspection, 2-1, 4-1
- Installation, Centrifuge, 2-2
- Installation, Rotor, 3-3
- Location, Centrifuge, 2-2
- Maintenance, 4-1
- Mass, Centrifuge, 1-2
- Mechanical Override Loop, 3-6
- Motor Brush Replacement, 4-3
- Ordering Information, 4-4
- Operating Temperature, RT6000B, 1-1
- Operation, Centrifuge, 3-4
- Parts, Ordering, 4-4
- Precool
 - Chamber, 3-4
 - Rotor, 3-3
- Reducing Rotor Speed, 3-6
- REV/MIN x 1000 Indicator
 - Adjustment, 4-2
- Rotor Chamber, Cleaning, 4-1
- Rotor Installation, 3-3
- Rotor RCF Information, 1-2
- Rotor Specifications, 1-2
- Rotor Temperature, 3-2
- Running Hazardous Material, 3-4
- Safety Information, iii
- Sample Recovery, 3-6
- Service Decontamination Policy, 4-5
- Speed
 - Operating, 1-1
 - Reducing, 3-6
- Temperature, Operating, RT6000B, 1-1
- Temperature, Rotor, 3-2
- Warranty, *See Appendix*