

MS Balances



The MS Balance Line

Performance you can trust

Reassuringly easy to use

Trusted Results at Your Fingertips
Worry-free Weighing

METTLER TOLEDO

Trusted Results at Your Fingertips

Worry-free Weighing

In today's high pressure research and manufacturing environments, having the right equipment is key to achieving quality and efficiency. With customers demanding short lead times and reliable delivery dates, you need a balance you can trust to deliver accurate results - and which is convenient and reassuringly easy to use.

METTLER TOLEDO's MS balances fit the bill. These robust balances incorporate advanced security features so that you know you can trust your results. User guidance, an intuitive graphical user interface and built-in applications make daily weighing tasks simple, even for untrained operators. Clever design features make MS balances easy to clean and take care of too.

Worry-free weighing with the MS balance portfolio

Intuitive to operate and easy to clean, MS balances bring a new level of comfort to your daily weighing tasks.

Precision balances Small and large platform



Max. capacity: 320 g – 32 kg
Readability: 1 mg – 5 g

Analytical and semi-micro balances



Max. capacity: 120 g – 320 g
Readability: 0.01 mg – 0.1 mg



Instruments reduced to the max ensure that everyone in the Inprocess Lab can weigh productively without worries.



Erwin W. Studer
Co-Owner, profact AG,
Manufacturing Consultants Switzerland

"Today, advanced companies run lean laboratories which are focused on delivering results in the most efficient way in terms of cost, speed and quality. Every device should support this goal."

With trusted performance and comfortable operation, MS balances fulfill your lean laboratory needs.

Small Precision Balances

Engineered for Reliable Performance

The robust construction of the MS small platform precision balances makes them perfect for heavier tasks in the laboratory or out on the factory floor. The unique MonoBloc weighing cell delivers the accuracy you need and is fully protected against accidental overload.

Delivering consistently reliable results, even in harsh environments, these balances will also deliver a fast return on your investment.

Proven weighing cell delivers reliable results

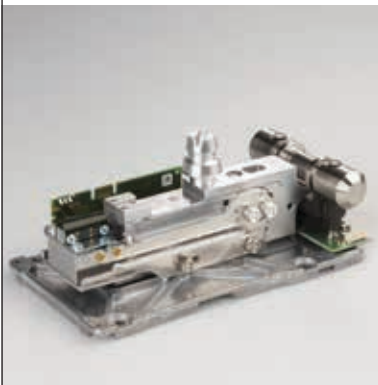

Our renowned MonoBloc weighing cell, with proFACT automatic internal adjustment, delivers consistently reliable results. Built-in overload protection ensures a long balance lifetime.

Automatic adjustment guarantees secure results



Fully automatic time and temperature controlled internal adjustment compensates for changes in ambient temperature which may affect the accuracy of your weighing results.

Improved stability means faster results



With three fixed feet and two LevelLock stands, MS balances are easy to level and sit solidly on your workbench. With the balance less susceptible to vibration, you get faster results.



The green screen clearly indicates that the result is within your pre-defined tolerances – this instant confirmation means applications such as check-weighing are much faster with fewer errors.

Metal housing ensures long balance lifetime

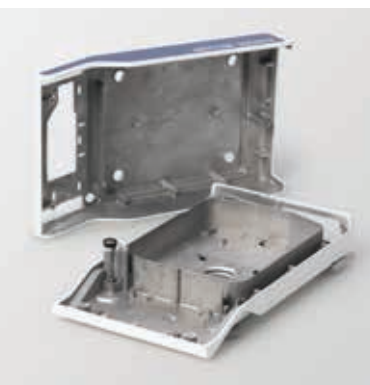

The full die-cast aluminium housing not only protects the weighing cell from environmental influences and impacts, it is also resistant to harsh chemicals, including acetone.

Small Precision Balances

Designed for Easy Operation

The built-in applications on MS balances provide you with straightforward user guidance, so you have the comfort of knowing that tasks are carried out correctly. Warning features, such as LevelControl and MinWeigh, give you a higher level of confidence in your results.

The extra-large touchscreen display is simple to operate, even whilst wearing gloves, and, with digits up to 18 mm in size, your results are clear to read. And when weighing tasks are complete, cleaning-up is easy thanks to the smooth, wipe-clean surfaces.

Optimized display makes daily tasks easier



The 7" extra-large color TFT touchscreen display is operable through cotton, silicon and rubber gloves. An intuitive user interface and 18mm high digits bring comfort to your daily tasks.

Built-in function simplifies balance leveling



The built-in LevelControl function issues a warning when the balance is not level and provides onscreen guidance to help you level the balance correctly within seconds.

MinWeigh function assists dosing process



During weighing-in, the weight value remains red until the net sample is above the pre-programmed minimum value. It's clear to see when process tolerances have been met.



The large draft shield protects the balance from air currents – ideal for delicate applications, such as determining the weight of coatings by differential weighing.



Personalized user profiles provide security and ease of use

- Operate the balance in your own language
- Save time with built-in applications
- Use passcodes to protect balance settings

► www.mt.com/ms-precision

Large Precision Balances

Tough Performers Built to Last

Accommodating loads up to 32 kg, MS large platform precision balances are built to take on your toughest jobs. The MonoBloc weighing cell, Ingress Protection rating IP65 and extreme overload protection ensure you get reliable results in even the most challenging industrial environments.

The large weighing platform is ideally suited to applications involving large containers, large sample sizes or when many ingredients need to be added to the same container. Easy-clean surfaces mean taking care of your balance is effortless too.

Robust construction handles your heavy samples



The tough metal housing and extreme overload protection of more than 100 kg safeguard your balance when working with heavy sample containers. The large weighing pan provides extra convenience.

Chemical resistance ensures longevity



The weighing pan and balance housing are resistant to the harshest of chemicals, including acetone, and help ensure a long balance lifetime.

IP65 protects against the toughest environments



To withstand the harshest of weighing conditions, selected MS large platform precision balances meet IP65 requirements for full protection against the ingress of dust and jets of liquid.



The large weighing platform is really convenient for totalization tasks with larger quantities of ingredients.



**Clever design details support
your daily tasks**

For example, the groove in the top of the weighing pan allows cylindrical samples to be placed directly on the balance without the need for an extra container.

► www.mt.com/ms-precision

MS Precision Balances

Technical Specifications

MS-TS Precision Balances, with Draft Shield

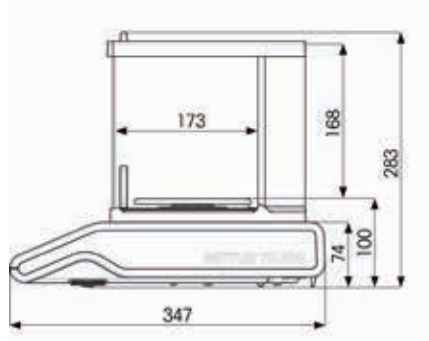

MS-TS Precision Balances

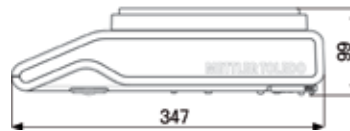

MS-L Precision Balances



All dimensions are given in mm.

MS-TS Precision Balances	1 mg, with draft shield				0.01 g – 0.1 g	
	Model	MS303TS	MS403TS	MS603TS	MS1003TS	MS1602TS
Maximum capacity	320 g	420 g	620 g	1020 g	1620 g	3200 g
Readability	1 mg	1 mg	1 mg	1 mg	0.01 g	0.01 g
Repeatability (at nominal load)	1 mg	1 mg	1 mg	1 mg	0.01 g	0.01 g
Settling time*	1.5 s	1.5 s	1.5 s	1.5 s	1.5 s	1.5 s
Minimum sample weight* (acc. to USP)	1.4 g	1.4 g	1.4 g	1.4 g	14 g	14 g
Minimum sample weight* (U=1 %, k=2)	0.14 g	0.14 g	0.14 g	0.14 g	1.4 g	1.4 g

MS-TS Precision Balances	0.01 g – 0.1 g					
	Model	MS4002TS	MS4002TS DR	MS6002TS	MS6002TS DR	MS120002TS
Maximum capacity (fine range/full range)	4200 g	820 /4200 g	6200 g	1220 / 6200 g	12200 g	8200 g
Readability, full range	0.01 g	0.1 g	0.01 g	0.1 g	0.01 g	0.1 g
Readability, fine range	-	0.01 g	-	0.01 g	-	-
Repeatability (at nominal load)	0.01 g	0.01 g	0.01 g	0.01 g	0.01 g	0.1 g
Settling time*	1.5 s	1.5 s	1.5 s	1.5 s	1.5 s	1 s
Minimum sample weight* (acc. to USP)	14 g	14 g	14 g	14 g	14 g	120 g
Minimum sample weight* (U=1 %, k=2)	1.4 g	1.4 g	1.4 g	1.4 g	1.4 g	12 g

MS-L Precision Balances	0.1 g – 1 g				1 g – 5 g, with IP65			
	Model	MS12001L	MS16001L	MS32001L	MS32000L	MS15KLE	MS30KLE	MS15KLIPE
Maximum capacity	12200 g	16200 g	32200 g	32200 g	15 kg	30 kg	15 kg	24 kg
Maximum capacity (approved version)	-	-	-	-	6 kg / 15 kg	15 kg / 30 kg	6 kg / 15 kg	15 kg / 24 kg
Readability	0.1 g	0.1 g	0.1 g	1 g	2 g	5 g	2 g	5 g
Readability (approved version)	-	-	-	-	2 g / 5 g	5 g / 10 g	2 g / 5 g	5 g / 10 g
Repeatability (at nominal load)	0.1 g	0.1 g	0.1 g	1 g	1 g	2 g	1 g	2 g
Settling time*	2 s	2 s	2 s	1.5 s	0.8 s	0.8 s	0.8 s	0.8 s
Minimum sample weight* (acc. to USP)	140 g	140 g	140 g	1000 g	1640 g	4100 g	1640 g	4100 g
Minimum sample weight* (U=1 %, k=2)	14 g	14 g	14 g	100 g	164 g	410 g	164 g	410 g

* = typical value ** = High Capacity *** = Heavy Duty

Features		Small Platform	Large Platform	
		MS-TS Precision Balances	MS-L Precision Balances**	MS-L Precision Balances with IP65***
Accurate Results	MonoBloc weighing cell and overload protection	•	•	
	Strain gauge weighing technology			•
	proFACT - fully automatic time- and temperature-controlled internal adjustment	•	•	
	CalExt adjustment with an external weight			•
	MinWeigh warning function	•		
	Full metal housing	•	•	•
Efficient Operation	7" Extra large color TFT touchscreen (18 mm high digits)	•		
	HCD High contrast display (18 mm high digits)		•	•
	LevelControl function	•		
	Statistics - improved management of weighing data	•		
	Easy cleaning thanks to smooth, wipe-clean surfaces	•	•	•
	LevelLock – greater balance stability	•		
	Battery operation			•
	IP65 - for full protection against the ingress of dust and jets of liquid			•
Quality Assurance	ISO-Log-records important changes, e.g. adjustments, leveling status	•		
	Sample ID – avoids confusion between samples and provides traceability	•		
	Passcode protection - only authorized users can make adjustments	•		
	Menulock (settings protection)		•	•
Seamless Process	3 interfaces - USB device, USB host and RS232	•		
	2 interfaces - USB and RS232		•	
	RS232			•
	Bluetooth option	•	•	•
	PC Direct application for easy data transfer (no software needed)	•	•	•

Analytical Balances

Trusted Performance

The built-in security features on MS analytical balances ensure results are always valid. Operators receive a warning if any problems are encountered or tolerances are not adhered to. Corrective actions can be taken immediately, avoiding costly reworking later.

LevelControl, MinWeigh and automatic internal adjustment with proFACT support compliance with regulations. The ISOLog function maintains a record of all weighing relevant changes to the balance's settings. For additional security, settings can be passcode protected.

Built-in function simplifies balance leveling



The built-in LevelControl function issues a warning when the balance is not level and provides onscreen guidance to help you level the balance correctly within seconds.

MinWeigh function ensures process tolerances

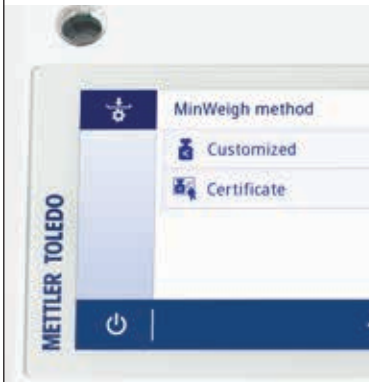

A user-defined minimum weight can also be programmed into the balance to provide an additional safety factor.

Passcodes protect balance settings



Create a passcode to restrict modification of balance settings to authorized personnel only – functions that affect metrological performance are protected against accidental alteration.



To ensure consistently accurate weighing results, the performance of your balance should be tested at regular intervals.



Easy routine testing

We offer two simple solutions to help you ensure your testing is always done correctly and on time: Our GWP® Verification service provides you with a detailed testing schedule according to your weighing risk and includes which tests, the test frequency and the correct weights to use.

► www.mt.com/gwp

With everything you need in one easy-clean box, our CarePac® weight sets ensure full compliance with GWP® as well as ISO, GLP and GMP.

► www.mt.com/weights

Analytical Balances

Comfortable Operation

Using the built-in applications, simple instructions guide you through your weighing tasks. You can rest assured that your process tolerances are adhered to and your results meet the relevant regulations. The risk of human error is greatly reduced.

Simplify your weighing tasks even further by connecting your balance with external devices: barcode reader, wireless printer, auxiliary display and more, and enjoy worry-free weighing!

Optimized display makes daily tasks easier



The 7" extra-large color TFT touchscreen display is operable through cotton, silicon and rubber gloves. An intuitive user interface and 18mm high digits bring comfort to your daily tasks.

Up to 4 IDs per sample ensure traceability



Enter up to 4 IDs per sample using the built-in touchpad or a barcode reader for fast and reliable traceability (e.g. user, sample, batch etc.).

Easy-cleaning features save time and effort



The QuickLock draft shield dismantles in seconds without any tools and all parts are dishwasher proof. Surfaces are smooth and rounded to make cleaning easy.



Simplify your daily weighing tasks by handling your data electronically – save time and reduce errors.

► www.mt.com/ms-analytical

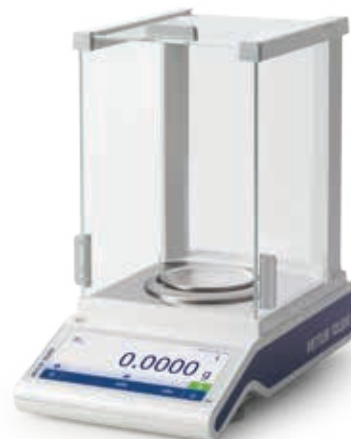

Get connected for easy data handling

Make processes simpler and more secure by, for example, connecting a barcode reader for error-free input of sample IDs, and using the Bluetooth adapter to send results wirelessly to a printer outside your working area.

- USB Host, USB Device, RS232, Bluetooth (optional)
- Built-in PC Direct function – easy data transfer without PC software

Semi-micro Balances for Higher Accuracy Needs

With 10 µg readability, MS semi-micro balances are perfect for weighing your smallest samples. The high resolution technology (HRT) weighing cell is made in Switzerland and guarantees your results are accurate and reliable.

Thanks to the special draft shield doors, dosing procedures are comfortable and efficient. In addition, with a tall draft shield and maximum balance capacity up to 220 g, standard-sized containers can be used.

Two internal weights ensure accurate results



Time and temperature controlled automatic internal adjustment (proFACT) uses the two built-in weights to test for sensitivity and non-linearity to ensure consistently accurate results.

Space-saving doors enable ergonomic dosing



The doors do not project beyond the balance so you save valuable bench space. To enable ergonomic dosing processes, the right hand door can be opened with the left lever – and vice versa.

Built-in application confirms pipette accuracy



Quickly convert your micro-analytical balance into a pipette checking station by installing an evaporation trap. The built-in application guides you through the pipette check process.



High productivity thanks to a fast settling time and reliable minimum sample net weight.



eLearning "External Influences and Cleaning"

Learn from our experts how you can ensure you get the best results from your balance. This online course focuses on the 6 most common external influences which can affect your weighing results and how to eliminate them. It also offers guidance on the ideal location of a balance in the lab and proper methods for cleaning.

► www.mt.com/lab-elearning

MS Analytical and Semi-micro Balances

MS Semi-micro Balances

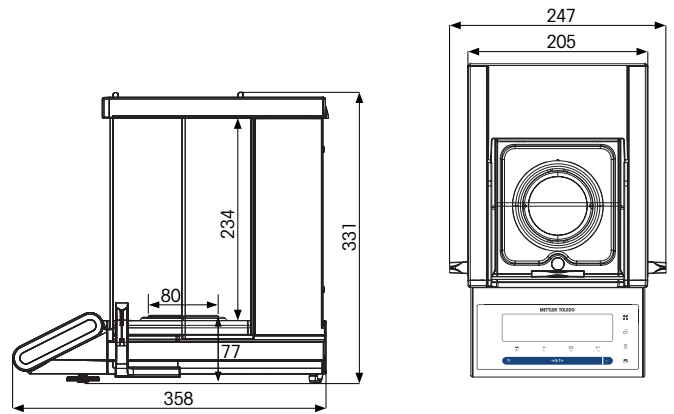

MS-TS Analytical Balances

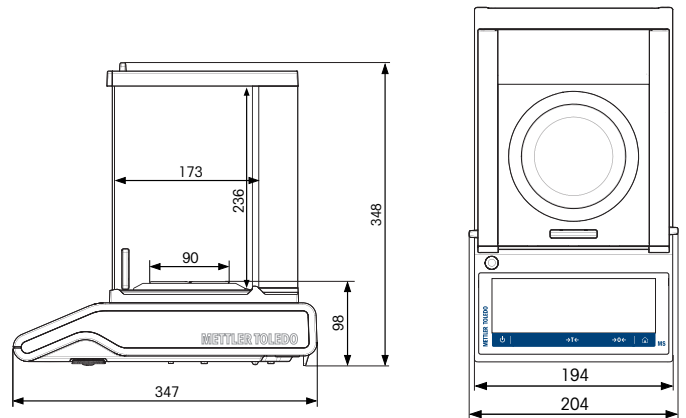

All dimensions are given in mm.

MS Semi-micro Balances 0.01 mg	MS105	MS105DU	MS205DU	MS204**
Maximum capacity (fine range/full range)	120 g	42 / 120 g	82 / 220 g	220 g
Readability, full range	0.01 mg	0.1 mg	0.1 mg	0.1 mg
Readability, fine range	-	0.01 mg	0.01 mg	-
Repeatability (at nominal load)	0.04 mg	0.08 mg	0.08 mg	0.09 mg
Repeatability (at low load)	0.02 mg (10 g)	0.02 mg (5 g)	0.02 mg (10 g)	0.07 mg (10 g)
Settling time* (fine range/full range)	3 s	3 s / 1.5 s	3 s / 1.5 s	1.5 s
Minimum sample weight* (acc. to USP)	30 mg	30 mg	30 mg	100 mg
Minimum sample weight* (U=1 %, k=2)	3 mg	3 mg	3 mg	10 mg

* = typical value ** = MS Semi-micro design with 0.1 mg readability

MS-TS Analytical Balances 0.1 mg	MS104TS	MS204TS	MS304TS
Maximum capacity	120 g	220 g	320 g
Readability	0.1 mg	0.1 mg	0.1 mg
Repeatability (at nominal load)	0.1 mg	0.1 mg	0.1 mg
Settling time*	2 s	2 s	3 s
Minimum sample weight* (acc. to USP)	160 mg	160 mg	160 mg
Minimum sample weight* (U=1 %, k=2)	16 mg	16 mg	16 mg

* = typical value

Features		MS Semi-micro	MS Analytical
Accurate Results	High resolution weighing cell (HRT) with two built-in adjustment	•	
	MonoBloc and strong overload protection		•
	proFACT - fully automatic time- and temperature-controlled internal adjustment	•	•
	Low minimum weight	•	
	MinWeight warning function		•
	Full metal housing	•	•
Efficient Operation	7" Extra Large Color TFT touchscreen (18 mm high digits)		•
	HCD High contrast display (18 mm high digits)	•	
	LevelControl function		•
	Statistics - improved management of weighing data		•
	Easy cleaning, incl. QuickLock for easy glass panel removal	•	•
	ErgoDoor left/right operation	•	
	Telescopic draft shield doors for reduced footprint	•	
Quality Assurance	ISO-Log records important changes, e.g. adjustments, leveling status		•
	Sample ID avoids confusion between samples and provides traceability		•
	Passcode protection restricts adjustment only to authorized users		•
	Menulock (Settings protection)	•	
	PipetteCheck with evaporation trap (optional)	•	
Seamless Process	3 interfaces - USB device, USB host and RS232		•
	2 interfaces - USB and RS232	•	
	Bluetooth option	•	•
	PC Direct application for easy data transfer (no software needed)	•	•

METTLER TOLEDO Services

Ensure Consistently Reliable Results

From evaluating your needs to select the right balance, through to daily routine operation in your lab, the METTLER TOLEDO Sales & Service Team can accompany you every step of the way. Our expertise means you can enjoy excellent performance, maximum uptime and full compliance with the norms and standards relevant to your industry.



Good Weighing Practice™

METTLER TOLEDO developed GWP® (Good Weighing Practice™) as a standardized scientific methodology for the secure selection, operation and calibration of weighing equipment. GWP® is applicable to all weighing equipment from any manufacturer.

Evaluation and selection



Our GWP® Recommendation service helps you select the right balance according to your specific process and quality requirements. Documentary evidence is provided to show that the selected balance meets metrological, environmental and regulatory requirements.



Global Reach – Local Presence! A team of 5,000 specialists represent METTLER TOLEDO Sales and Service in more than 140 countries worldwide.

► www.mt.com/service

Installation



We document the installation and qualification of your balance in accordance with the relevant industry regulations. Operator training right after installation leads to improved productivity.

Calibration



Balance calibration is at the core of accurate weighing results. Each calibration certificate declares the balance's minimum weight and measurement uncertainty – essential information for reliable weighing processes.

Routine operation



GWP® Verification provides clear guidance for performance verification of your balance to save you time and money. Included is an optimal routine testing and calibration schedule, specifications of the required test weights, and the ideal maintenance plan.

Accessories and Options for Worry-free Weighing

METTLER TOLEDO balances can be customized with accessories and peripheral devices to meet the needs of virtually any application. Our carefully designed accessories make your work easier, convenient and help increase efficiency.

Reliable sample transfer



SmartPrep™ single-use, antistatic funnels enable safe and fast weighing-in of powders. Simply weigh, transfer and rinse. Fits nearly any standard 10 – 250 mL flask.

Protect results from static



The freestanding U-Electrode removes electrostatic charges on samples and containers.

Fast density determination



Dedicated kit for determining the density of solid and liquid substances with the built-in application.

No cables with Bluetooth



Simply plug in a BT adapter where there is no built-in BT interface to wirelessly send data between your balance and a PC, tablet or printer. No additional software needed.

Easy documentation



The P-5x thermal printers generate fast, high quality printouts on paper, self-adhesive labels and continuous self-adhesive paper (including barcodes).

Faster results



The large draft shield protects your balance from air currents which may prevent your balance settling, e.g. from air conditioning. Get faster and more accurate results.



The built-in PC Direct application transfers results immediately to an open application on your tablet or PC, e.g. an Excel spreadsheet.

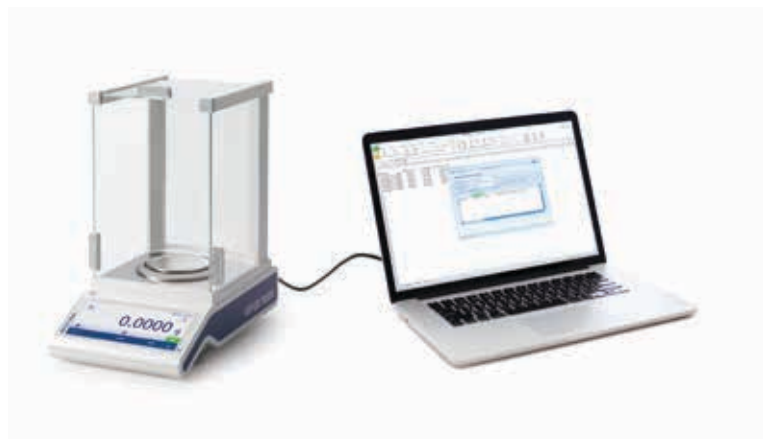

Easy Data Transfer

Flexible connectivity options for balances simplify and speed up your daily work in the laboratory.

LabX direct balance software simplifies data management:

- Configurable data layout
- Transfer date, time, unit and sample ID
- Fast and error-free data transfer (e.g. MS Office application, ERP system)

Benefit From Our Weighing Expertise

With decades of experience in laboratory weighing, METTLER TOLEDO can offer you a wide range of online learning resources. Take advantage of our expertise to enhance your weighing know-how and ensure you benefit from all the power that your balances offers. Check out the documentation on our internet page for a range of relevant materials.



Videos

In an easy learning format, our videos demonstrate the use of our balances and inform you about our weighing solutions. For example:

- Antistatic Solutions
- Easy Cleaning

► www.youtube.com/mtlaboratory



eLearning

Online training is a cost effective way to train new employees and fulfill GLP/GMP/ISO re-training requirements. Get going with:

- USP Compliance
- Lab Balances – External Influences and Cleaning

► www.mt.com/lab-elearning



On-demand Webinars

Learn directly from our weighing experts and guest speakers. It's easy to register.

For starters, we recommend:

- Minimizing Out-of-Specification Errors
- Good Weighing Practice

► www.mt.com/webinars

www.mt.com/balances

For more information

Mettler-Toledo AG
Im Langacher 44
8606 Greifensee, Switzerland
Tel. +41-44-944 22 11
Fax +41-44-944 30 60

Subject to technical changes.
© 12/2014 Mettler-Toledo AG
30245928
Global MarCom Switzerland

