



**BACTRON ANAEROBIC
CHAMBERS**

**BACTRONEZ BACTRONEZ-2
BACTRON300 BACTRON300-2
BACTRON600 BACTRON600-2**

OPERATION MANUAL

**Previously designated as:
BACTRONI, BACTRONI-2,
BACTRONII BACTRONII-2,
BACTRONIV, BACTRONIV-2**

Sheldon Manufacturing Inc. P.O. Box 627 Cornelius, Oregon 97113
EMAIL: tech@Shellab.com INTERNET: <http://www.Shellab.com/~Shellab>
1-800-322-4897 (503) 640-3000 FAX (503) 640-1366

Revised 11/2013
4861118M

TABLE OF CONTENTS

	Orientation
	Component Drawings
1.0	Receiving and Inspection
2.0	Installation
3.0	Controls Overview
4.0	Hose and Electrical Connections
5.0	Manometer
6.0	Catalyst Cartridge
7.0	Thermoelectric Condensate Controller
8.0	Incubator Temperature Controller/Incubator Safety
9.0	Incubator Calibration
10.0	Vacuum Gauge Adjustment
11.0	Pressure Adjustment
12.0	Testing The Chamber For Gas Leaks
13.0	Making The Chamber Anaerobic/Desired Environment
14.0	Chamber Operation
15.0	Entering The Chamber
16.0	Exiting The Chamber
17.0	Maintenance
18.0	Chamber QC Sheet
19.0	Accessories
20.0	Chamber System Drawings:
	A) Keeping The Chamber Anaerobic
	B) The System Controller and Controls: View From Behind Panel
	C) Solenoid
	D) The System Controller Indicator Guide
21.0	Troubleshooting Section
22.0	Bactron Operation Tips
23.0	Wiring Diagrams
24.0	Parts List
25.0	Loop Sterilizer

IMPORTANT: READ THIS INSTRUCTION MANUAL IMMEDIATELY.

Your satisfaction and safety require a complete understanding of this unit, including its proper function and operational characteristics. Be sure operators are given adequate training before attempting to put the unit in service. **NOTE: This equipment must be used only for its intended application; any alterations or modifications will void your warranty.**

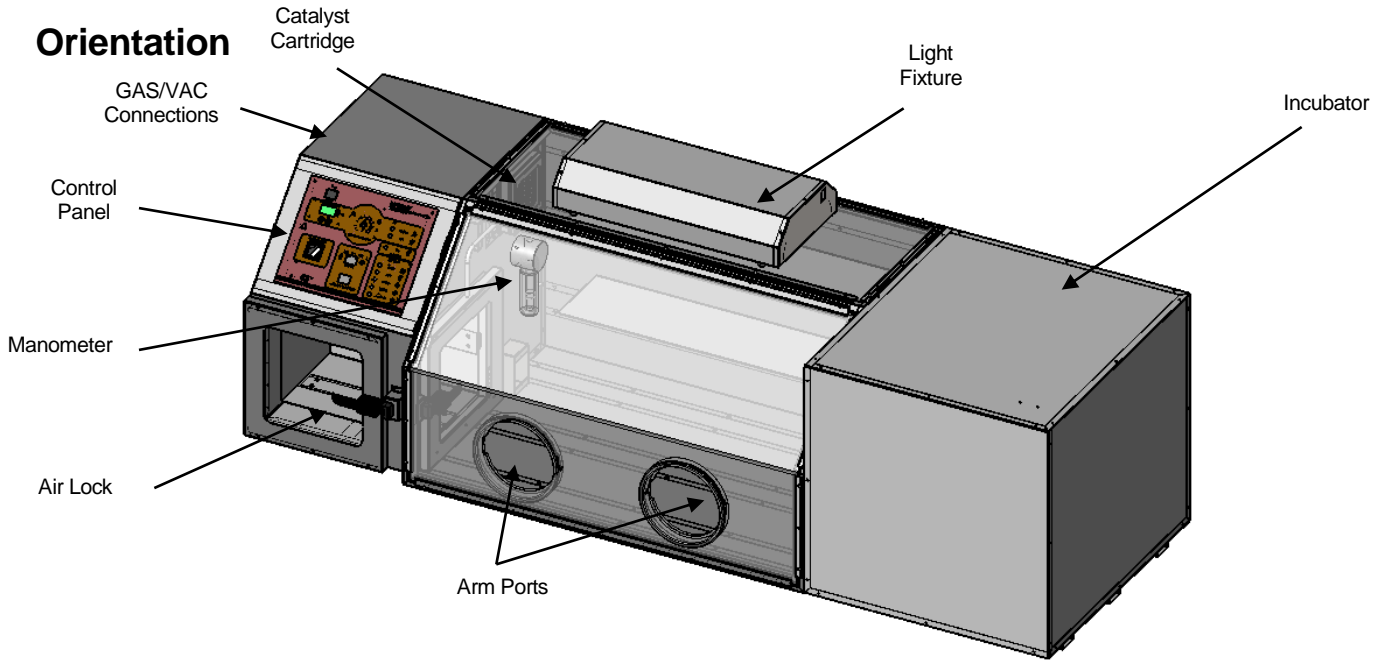

Figure 1. Bactron600 / Bactron600-2 Chamber

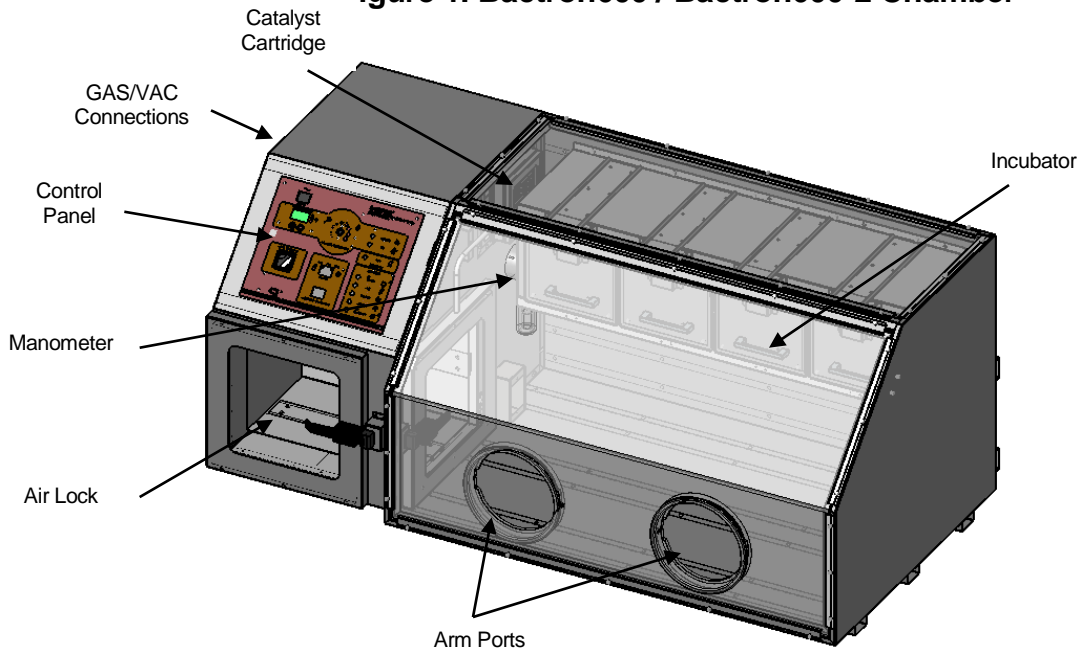

Figure 1a. Bactron300 / Bactron300-2 Chamber

Note: The BACTRONEZ and BACTRONEZ-2 (Bactron I BactronI-2) Chamber is similar; it has three incubator compartments.

Components



Figure 1: Sleeve/Cuff Assembly

The Sleeve/Cuff Assembly consists of a neoprene sleeve, a plastic cuff ring, O-Ring, and a soft rubber cuff. Unit comes with Laytex Gloves and Cuffs. Nitril Gloves and Cuffs may be ordered from the Parts List. The assembly allows gloveless chamber operation.



Figure 2: Arm port Doors

CAUTION: The Bactron chambers have an efficient method of sealing the chamber by utilizing the Arm port doors as shown in Figure 3. The tightening knob on the Arm port doors should be turned just until the knob begins to “grab”. **DO NOT OVER TIGHTEN.** Damage can occur if too much force is placed on the Arm port door assembly.

Doors are used to seal the Arm ports while the chamber is not in use. Doors can be stored using the holders provided while the chamber is in use. Assembly consists of an Arm port door, tightening knob and locking bar. Doors are secured by tuning the locking bars horizontally to pass through the cutouts in chamber, then turning locking bars verticals and tightening knobs.

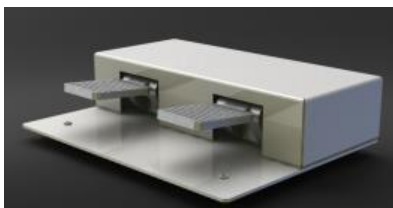
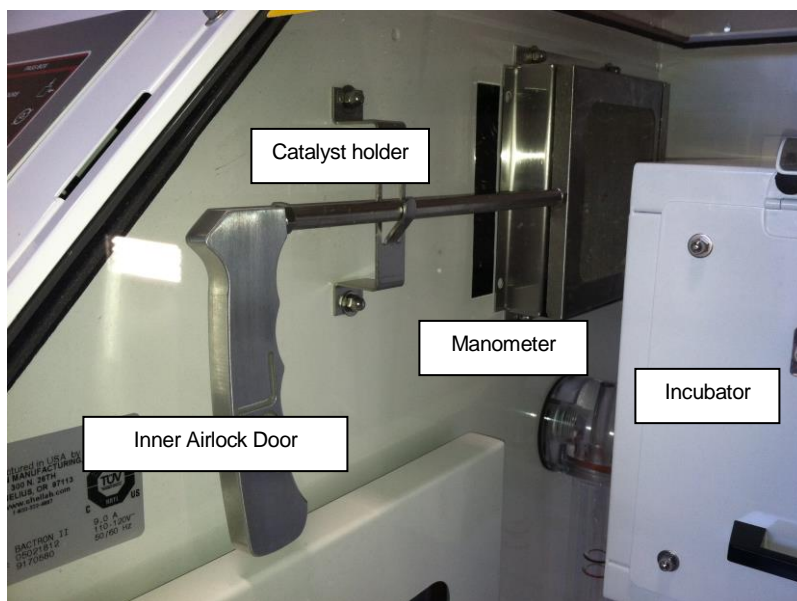

Figure 3: Foot Pedals

Utilize to exchange the sleeve atmosphere (room) with the desired chamber environment (gas mixture).



Figure 4. Catalyst Cartridge



Two catalyst containing Palladium catalyst pellets are supplied to remove trace amounts of oxygen.

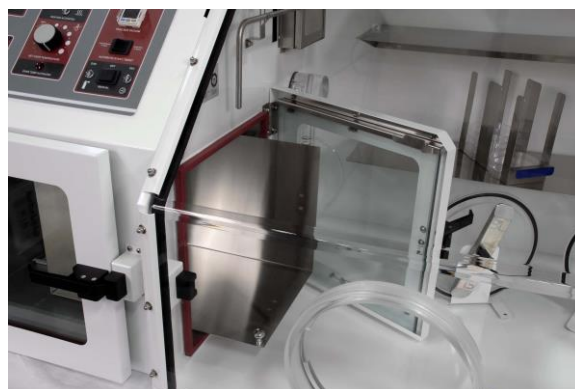

Figure 5. Air Lock

The Air Lock provides ability to take material into and out of the chamber. Air Lock can be operated either automatically or manually. The Air lock shelf allows for materials to be conveniently rolled from the Air Lock into the chamber.

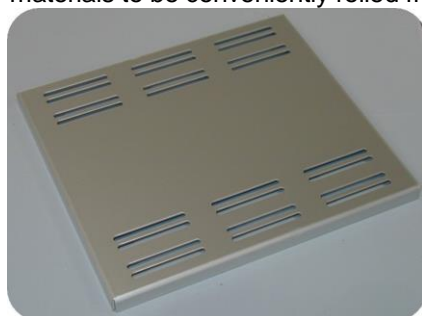

Figure 6: Incubator Bottom Shelf Spacer

1.0 RECEIVING AND INSPECTION

- 1.1 The carrier, when accepting shipment, also accepts responsibility for safe delivery and is liable for loss or damage claims. On delivery, you must inspect for visible exterior damage. Note and describe on the freight bill any damage found and enter your claim on the form the carrier supplies.
- 1.2 Inspect for concealed loss or damage on the unit itself, both interior and exterior. If any, the carrier will arrange for official inspection to substantiate your claim. Save the shipping crate until you are sure the unit has been delivered in good condition.
- 1.3 If for any reason you must return the unit, contact your sales representative for authorization and supply nameplate data.

2.0 INSTALLATION

- 2.1 Local city, county, or other ordinances may govern the use of this equipment. If you have any questions about local requirements, please contact the appropriate local agency.
- 2.2 Under normal circumstances these units are intended for use indoors, at room temperatures between 5° and 40°C, at no greater than 80% relative Humidity (at 25°C) and with a supply voltage that does not vary by more than 10%. These chambers should not be operated at an altitude exceeding 2000 meters. Installation category is CAT-II.
- 2.3 Pollution Degree 2. Customer service should be contacted for operating conditions outside of these limits. Installation may be performed by the end user. It is unnecessary for this unit to be installed by a technician.
- 2.4 **Location:** When selecting a site for the unit, consider conditions which may affect performance, such as heat from steam radiators, ovens, autoclaves, etc. Avoid direct sun, fast-moving air currents, heating/cooling ducts, and high traffic areas. To ensure air circulation around the unit, allow a minimum of 2" between chamber rear and sides and any walls, partitions, or obstructions to free airflow.
- 2.5 **Power Source:** The power source must match the voltage, cycle, phase and amperage requirements listed on the data plate. Plug the cord into a grounded outlet. **VOLTAGE OF THE OUTLET SHOULD NOT VARY MORE THAN 10% FROM THE DATA PLATE RATING.** A separate circuit is recommended to precluded loss of product due to overloading or circuit failure. Note that the electrical supply to the unit must conform to all national and local electrical codes.
- 2.6 **Gas Source:** Install the gas regulator(s) on the tank(s) of gas. Chain the gas tanks(s) to a secure position on the wall. **Set the regulator(s) to 15-20 psi.**
- 2.7 If you are using an anaerobic gas mixture (AMG), we recommend 5% (H₂), 5% Carbon Dioxide (CO₂), and 90% Nitrogen(N₂).
- 2.8 If you are using a two gas anaerobic application, we recommend one tank of AMG gas and the second tank of 100% Nitrogen (N₂).



Figure 7. Warning Label

- 2.9 **Cleaning:** The Bactron unit was cleaned at the factory, however, a general cleaning is recommended. Use BENZALKONIUM CHLORIDE to clean your chamber. See list of cleaning products.

3.0 CONTROLS OVERVIEW

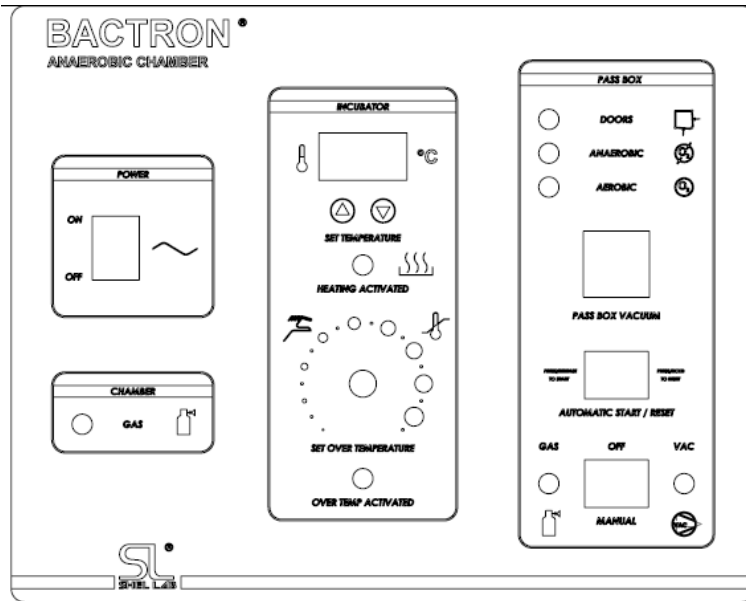

Figure 8. Control Panel

- 3.1 **Power:** The lighted power “I/O” switch controls all power to the Bactron Chamber. It must be in the “I” position before any systems are operational, including control circuitry.
- 3.2 **Digital Display:** The actual incubator temperature will be digitally displayed to $\pm .1^{\circ}\text{C}$.
- 3.3 **Main Temperature Control:** This control consists of the Up/Down buttons and the digital display.
- 3.4 **Vacuum Gauge:** Digital readout shows the vacuum level of the Air Lock in inches of mercury.
- 3.5 **Incubator Over Temperature Limit (OTL):** The OTL is an independent thermostat that monitors incubator temperature. It guards against any failure of the incubator controller which would allow temperature to rise past set point. If temperature rises to the OTL set point, the OTL will take over control of the heating element and an audible alarm will be activated. The OTL controller allows for continued use of the chamber until service can be arranged.
- 3.6 **Air Lock Controls. Manual Cycle:** The manual cycle switch controls the vacuum and the gassing process of the Air Lock. Push VAC to evacuate the Air Lock then GAS to fill the Air Lock with the desired gas mixture. This process should be done three times.
- 3.7 **Air Lock Controls. Auto Cycle:** The automatic cycle switch will evacuate the Air Lock and then fill the chamber with the desired gas mixture. The process will cycle three times and upon completion the ANAEROBIC light will activate. The cycle can be aborted by pressing the switch to the START/RESET and holding it down for five seconds.
- 3.8 **Incubator Heating:** Light indicates that the heating element is activated and that the incubator is heating.
- 3.9 **Over Temperature Limit (OTL) Activated:** Light indicates that the Incubator OTL audible alarm is activated and controlling the incubator temperature.
- 3.10 **Chamber Gassing:** Light indicates that the chamber is demanding gas.
- 3.11 **Air Lock Doors Sealed:** Light indicates that both the Air Lock doors are closed.
- 3.12 **Gas Activated:** In the manual cycle the GAS light indicates that the Gas switch is activated. In the automatic cycle, third cycle, light indicates that the GAS is activated in the Air Lock.
- 3.13 **Vacuum Activated:** Light indicates that the VAC switch of the manual cycle Air Lock is activated. Light is also on during automatic vacuum cycles.
- 3.14 **Auto Cycle Aerobic:** Light indicates that the Auto cycle has not been activated. When the automatic cycle has been activated, the Auto Cycle Anaerobic lights will alternate.
- 3.15 **Auto Cycle Anaerobic:** Light indicates that the Auto Cycle has been activated and is complete. When the automatic cycle has been activated, the Auto Cycle Anaerobic lights will alternate.

4.0 HOSE AND ELECTRICAL CONNECTIONS

- 4.1 Hose ports for the gas and vacuum supplies and foot pedal controls are provided on the upper left side of the control module section. Bactrons have five access ports. (older models have four access ports.) See Diagrams Section for more details.
- 4.2 Install the hose from the gas regulator of the working gas, for example AMG, (GAS 1) tank to the port marked "**GAS 1**" on the chamber module.
- 4.3 Install the hose from the gas regulator of the purging gas, for example Nitrogen, (GAS 2) tank to the port marked "**GAS 2**" on the chamber module.

NOTE: If using only one gas supply, install the "T" tube/fitting assembly (provided in the accessory pack) between the "GAS 1 IN" port and the "GAS 2 IN" port on the control module. Then attach the hose from GAS 1 tank regulator, as in 4.2, to the unused brass "T" tube end. Failure to follow this procedure will render the purging cycles of a single gas system inoperative.

- 4.4 Connect the 3/8" hose from the vacuum pump or a 3/8" hose from a suitable in-house vacuum system, to the port marked VAC IN. In-house vacuum systems must be capable of evacuating to a minimum of 25 inches of mercury.
- 4.5 Plug the vacuum pump power cord into the outlet receptacle at the top left of the control module. This outlet is marked "**5 AMPS**" (installations using in-house vacuum supplies will not follow this step).

NOTE: CONNECTING HOSES. Hose connections are intended to be simple. Insert the hose into the appropriate connector until the hose stops. Pull back slightly to ensure hose will stay in place. Reinsert if hose pulls out.

- 4.6 Connect the center "T" section from the foot pedal assembly to the tube fittings located on the inner sides of the arm port access openings on the front of the chamber.
- 4.7 Connect the tube from the GAS side of the foot pedal assembly to port marked GAS OUT on the control module section.
- 4.8 Connect the tube from the VAC side of foot pedal assembly to the port marked VAC OUT on the control module section.
- 4.9 Plug power cord from Chamber into a suitable outlet. Refer to the Installation Section of this manual for additional information. Turn the power switch ON to verify power to the system.
- 4.10 When the main power switch is turned on, the vacuum pump should come on for a few seconds and then go off. If the pump does not come on, or comes on and will not go off, consult the Troubleshooting Guide for adjustment.
- 4.11 When the power switch to the Chamber is turned on, you should see Power ON, **CHAMBER GASSING, AIR LOCK DOORS SEALED** and **AUTO CYCLE AEROBIC** lights illuminate, along with readout of the incubator temperature. If any of these appear not to work, consult the Troubleshooting Guide.

5.0 MANOMETER

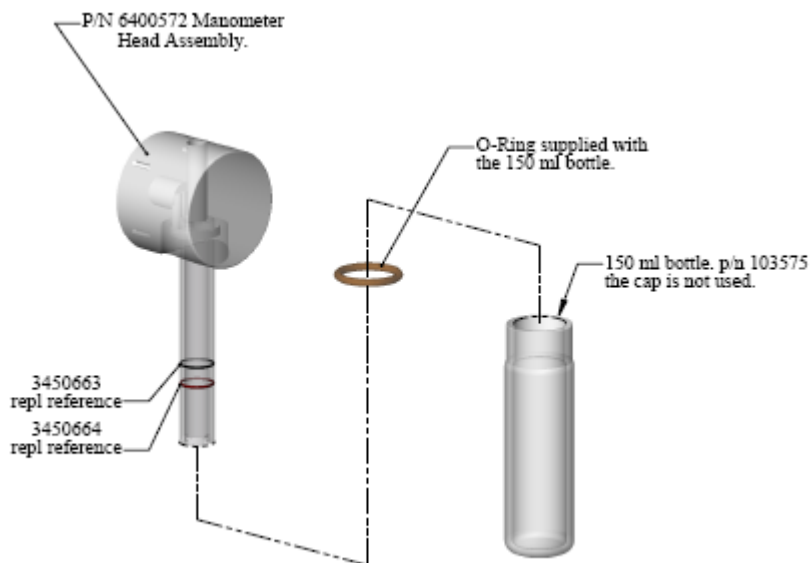

Figure 9 Manometer

The water filled Manometer gives the user a visual way to measure the pressure in the chamber. It also acts as a pressure release system to prevent damage to the chamber in case of inadvertent over-pressurization.

- 5.1 Purpose:** The function of the manometer is two-fold:
- Provides visual way to measure the pressure in the chamber. As the pressure inside the chamber increases, the water level in the inner tubes moves down a distance proportional to the pressure increase. By measuring the difference of the inner and outer water levels, the user can obtain the chamber pressure in inches of water. A water level indicator notifies user that water is high or low.
 - It acts as a pressure release system to prevent damage to the chamber in case of inadvertent over-pressurization. If the pressure becomes too great, the excess gas simply bubbles through the water and out the back of the chamber.
- 5.2 Filling Procedure:** Unscrew the bottle to fill the manometer with distilled water to a level of two or three inches. Lines on the manometer provide a guide. Fill water to the top line. This may be done from the top of the manometer inside the chamber.
- 5.3** The water reservoir can be periodically removed and cleaned. Remove by turning the glass bottle counter clockwise. Be careful not to damage the dip tube. To install, simply reverse this process.

6.0 CATALYST CARTRIDGE

- 6.3** The catalyst cartridge removes all trace amounts of oxygen from the chamber. Two catalyst cartridges containing Palladium catalyst pellets are provided.
- 6.4** One cartridge should always be in the chamber. The second spare cartridge is provided so that reactivation of the catalyst can be done after each chamber usage.
- 6.5** The catalyst cartridge is installed on the left wall inside the chamber. To install slide the cartridge into the metal tracks and secure the handle into the bracket.
- 6.6** Reactivate spare catalyst daily by heating for a minimum of 1 –1/2 to 2 hours at 160°C (320°F). You may keep the unused cartridge in the heating oven at 160° prior to its use. (NOTE: Catalyst cartridge should be reactivated for the first time before installing into the unit.)
- 6.7** Quality control catalyst monthly by flowing anaerobic gas over the reactivated pellets. If the pellets become warm to hot, they are working properly and are ready for use in the chamber. If they do not heat up when the gas is applied, reheat to 180° to 200°C and flow gas over catalyst again to remove any buildup of sulfides that might hinder its effectiveness.

-
- 6.8 The entire catalyst cartridge can be placed in the heating oven for reactivating. However, if necessary, the handle on the cartridge can be removed.
 - 6.9 A catalyst cartridge can also be placed inside the Air Lock to remove any trace amounts of oxygen.

7.0 THERMOELECTRIC CONDENSATE CONTROLLER

- 7.1 The thermoelectric condensate controller collects excess humidity and eliminates chamber condensation. Moisture is funneled into a tube for collection inside your chamber.
- 7.2 The thermoelectric condensate controller is located on the left side of the chamber interior behind the catalyst cartridge. A plastic tube drains excess moisture into the working chamber, on the back left side.
- 7.3 Place a container, e.g., glass flask or beaker, under the tube for collection. Empty the container **DAILY**.
- 7.4 Desiccants are not recommended in the chamber. Desiccants are drying agents that can pull moisture from your samples.

8.0 INCUBATOR TEMPERATURE CONTROLLER/INCUBATOR SAFETY

Under certain circumstances, samples placed directly on the bottom shelf may become too hot and dry out. Shelf spacers are provided to minimize this condition. Place spacers on the bottom shelf. Note the slots go to the front and back.

- 8.1 **Setting Incubator Controller:** The INCUBATOR TEMPERATURE controller regulates the incubator temperature by use of Up/Down buttons. To enter set point mode on the control, press either the Up or Down button one time. The digital display will start to blink, going from bright to dim. While blinking, the Digital Display is showing the set point. To change the set point, use the Up and Down buttons. If the buttons are not pressed for five (5) seconds, the display will stop blinking and will read the temperature of the unit. Note that the INCUBATOR SAFETY should be turned to its maximum position, (clockwise) until the unit has stabilized at desired set point temperature. Allow the incubator at least 24 hours to stabilize. Then re-calibrate the digital display to your reference thermometer, follow the calibration instructions. This incubator was calibrated at the factory at 37°C.
- 8.2 **Setting Incubator Safety:** First, set the control to the desired incubator temperature and set the INCUBATOR SAFETY to its maximum position. Allow 24 hours for stabilization before proceeding. If, after 24 hours the temperature is not at desired level, adjust the INCUBATOR TEMPERATURE up or down until the precise desired temperature is achieved. (See Section 9 for calibration procedures)
- 8.3 When stabilization at the desired temperature has been achieved, turn the INCUBATOR SAFETY control knob counter-clockwise until the INCUBATOR SAFETY ACTIVATED light comes on and audible alarm is activated. Next, carefully turn the INCUBATOR SAFETY knob clockwise until the light is just off. The Safety is now set; the INCUBATOR SAFETY ACTIVATED light should remain OFF during normal operation.
NOTE: An accurate thermometer should be used inside the incubator as a reference when setting and calibrating the incubator temperature.
- 8.4 It is a good idea to mark the INCUBATOR SAFETY label with the desired setting or position as a backup in case the knob is moved accidentally. If the SAFETY ACTIVATED light is on and audio alarm is activated at any time, check the INCUBATOR TEMPERATURE controller setting to be sure that it is not set above the INCUBATOR SAFETY setting.

9.0 INCUBATOR CALIBRATION

- 9.1 Compare the reading of the digital temperature display to an accurate reference thermometer. If there is a difference, put the display into calibrate mode by pressing both the Up and the Down buttons at the same time and holding them in for about five (5) seconds or until the two outside decimal points start to flash on and off.
When the decimal points are flashing, the display can be calibrated to match the reference thermometer by pressing the Up or Down button until the display reads correctly.

10.0 VACUUM ADJUSTMENT

10.2 The vacuum gauge for the Automatic Air Lock Cycle is factory calibrated. It is recommended that customers note the setting of the vacuum gauge during Auto Air Lock Cycle to ensure that the setting is correct. Evacuation and the vacuum pump capabilities can affect the calibration.

10.3 The Air Lock Auto Cycle settings are preset at the factory to 18 in. HG. (46 cm. Hg.) High and 4 in. Hg. (10 cm. Hg.) Low.

10.4 Setting Digital Vacuum Gauge:

Press the MODE and Up Arrow simultaneously and the display will illuminate three (3) letters with the far right letter flashing. The flashing letter can be changed by pressing the DOWN Arrow. By pressing the UP arrow, the display will select the next digit (letter) in the display and it will start flashing. It also can be changed by pressing the DOWN Arrow. It is the same for the third digit (letter) also. The letter setting should be set to read **IHD** in the display. After the letters are set, push the MODE Button to return to NORM operations.

Vacuum calibration procedure:

Low Limit

- A) Activate the Auto Air Lock Cycle and note the low level reached by the vacuum gauge. If the vacuum is not at the desired Low setting of 4, adjust the Low vacuum switch located in the same area as the high vacuum switch noted above.
- B) Repeat the procedure noted above under High vacuum to adjust the low Vacuum setting except adjust for the lower value of 4.

10.5 Front Panel Vacuum Gauge Parameter Setup (7850552)

To set Parameters: PUSH and HOLD the MODE Button for 2 seconds to get to the MENU setting MODE. Use the UP and DOWN Arrows to choose which Parameters to set. After Parameter is chosen, push the MODE Button to select and move to the next set of Parameters. After the last set Parameter is set, it will return to RUN MODE.

PARAMETER SETTING	
BOTTOM DISPLAY	UPPER DISPLAY
OUT1	EASY
OUT2	EASY
NONc	Lo2o
Sped	2.5
CLOr	GREn
UNIT	inHg

10.6 Setting Vacuum Gauge Set Points

Push and release the MODE button once and P-1 will flash. Use the UP and DOWN Arrows to set the SET POINT. Push and release the MODE Button again and P-2 will flash. Use the UP and DOWN Arrows to set the SET POINT.

P-1 = -18

P-2 = -4

10.7 Side Panel Vacuum Gauge Parameter Setup

To set Parameters, push and hold the MODE Button for 2 seconds to get to Menu Setting Mode. Use the Up and Down Arrows to choose which parameter to set. After Parameter is chosen, push the MODE Button to select and move to the next set of Parameters. After the last set Parameter is set, it will return to RUN MODE.

PARAMETER SETTING	
BOTTOM DISPLAY	UPPER DISPLAY
OUT1	HyS
OUT2	OFF
NONc	NO
Sped	2.5
CLOr	GREn
UNIT	inHg

10.8 Setting Vacuum Gauge Set Points

Push and release the MODE button once and LO-1 will flash. Use the UP and DOWN Arrows to set the SET POINT. Push and release the MODE Button again and HI-1 will flash. Use the UP and DOWN Arrows to set the SET POINT.

LO-1 = -20.3

HI-1 = -19.3

11.0 TESTING THE CHAMBER FOR GAS LEAKS

- 11.1 Each chamber is individually tested at the factory before shipping. The following procedure, however, should still be followed to detect any possible damage due to shipping.
- 11.2 Make sure the catalyst is removed from the chamber during initial leak testing.
- 11.3 Check to ensure Manometer is filled.
- 11.4 Close the outer and inner air Lock doors.
- 11.5 Secure the Arm port doors. Turn the locking bars horizontally to pass through the cutouts in the chamber, then turn bars so they are vertical, tighten knobs. **Do not over tighten.**
- 11.6 Open the gas tank valve all the way on and set the gas regulator to 15-20 psi.
- 11.7 Turn the power switch on. As before, with the power switch on, you should see the **POWER SWITCH**, **INCUBATOR TEMPERATURE** display, **CHAMBER GASSING**, **AIR LOCK DOORS SEALED**, and **AUTO CYCLE AEROBIC** light illuminate.
- 11.8 The **CHAMBER GASSING** light will turn OFF when the water level in the manometer reaches a level of approximately ½" of water. The **AIR LOCK DOORS SEALED** light will turn ON when the inner and outer Transfer Module doors are both closed. If this light is not ON, either the doors are not closed properly or one or both of the door sensors are improperly adjusted.
- 11.9 If there are no leaks in the system, the **CHAMBER GASSING** light will remain OFF, and the water level in the manometer will remain stable at approximately ½" water. Normally, a "leak-tight" chamber will go from 15 to 30 minutes without the **CHAMBER GASSING** light coming on again.
- 11.10 If the system has a gas leak, the **CHAMBER GASSING** light will flash ON and OFF. Flashing every 10-30 seconds indicates a very large leak, whereas flashing every 10 minutes or so indicates a small leak. This is accompanied by a "clicking" sound (originating from the chamber gas solenoid). In this case, check the following:
 - A) Arm port doors for adequate seal of O-rings.
 - B) Air Lock outer/inner door gaskets for adequate contact with doors.
- 11.11 If the system still has a leak, refer to:
 - A) Chamber Maintenance: Leak Detection
 - B) Trouble Shooting: Excessive Gas Consumption

12.0 MAKING THE CHAMBER ANAEROBIC/DESIRED ENVIROMENT

Prior to Purging The Chamber

- 12.1 Turn Power switch to the "O" (Off) position.
- 12.2 Place about six (6) oxygen indicators inside the system. Place one unopened indicator in the incubator, and place one unopened indicator in the work area. The others can be stored in the work area for future use.
- 12.3 Place catalyst in the chamber. For more information about the correct placement of the catalyst, see Section 6.0. Catalyst Cartridge.
- 12.4 Open the incubator doors before leaving the chamber. This allows the incubator to become anaerobic also.
- 12.5 Put arm port doors in place.

NOTE: The Bactron chambers have an efficient method for sealing the chamber by utilizing the Arm port doors as shown in Figure 3. The tightening knob on the Arm port doors should be snug, DO NOT OVER TIGHTEN. Damage can occur if too much force is placed on the Arm port door assembly. When

the knob just begins to “grab”, the tightening bolt has reached its maximum point. Over tightening will cause the bolt to slip inside the handle and cause leakage.

Purging the Chamber

- 12.6 Turn Power Switch to the “I” (On) position.
- 12.7 Note the reading on the gas regulator.
- 12.8 Loosen the right arm port door to create a small leak. (Remove sleeves from the arm ports if they have been placed there. This will make it easier to adjust the arm port doors to create the proper leak.) Adjust the doors so that the **CHAMBER GASSING** light flashes ON and OFF for equal periods. It is important that the gas flows into the chamber in “pulses” rather than as a “stream”. If the gas “streams”, it tends to go to the open door only.
- 12.9 Bleed the gas mixture through the chamber until the reading on the tank regulator gauge is 300-400 psi less than the original reading. Normally, it takes 1-1/2 to 2 hours to flush out all atmosphere from the chamber.
- 12.10 After the gas purge, tighten the arm port doors to prevent leaking. The **CHAMBER GASSING** light will turn off, flow of gas into the chamber will stop, and the water level difference in the manometer should again be approximately 1/2” and should remain stable.
- 12.11 At this point it is important to check if the chamber is completely anaerobic before using it. Check this by first replacing the sleeves on the arm ports, and the entering the chamber.
- 12.12 Once inside the chamber, open one indicator strip in the incubator and one strip in the work area.
- NOTE: Please note and follow the directions for use for the type of indicator strip you are using.**
- A) If the strips indicate that the atmosphere is anaerobic, the chamber is ready for use.
 - B) If the strips indicate an aerobic or slightly aerobic atmosphere, then exit the chamber. Create a small leak and flush an additional 100-200 psi through the chamber. After this step, proceed to step 12.11, until indicator strips indicate an anaerobic atmosphere.
 - C) The gas flowing through the chamber may cause previous indicator strips to dry out. Use fresh indicator strips each time you test the atmosphere.

NOTE: During the initial purge you may notice heavy condensation within the chamber. This is due to catalytic formation of water from hydrogen gas and oxygen initially in the chamber. Most of this condensation will dissipate by the end of the gas purge cycle.

CAUTION: The catalyst cartridge will be HOT at this point. If you must touch it for any reason, use extreme care.

Summary

The chamber is ready when:

- The **CHAMBER GASSING** light remains off indicating no gas leaks.
- The incubator doors are OPEN.
- Oxygen indicators are in the chamber.
- The catalyst cartridge is in place.

13.0 CHAMBER OPERATION

Air Lock Operation

- 13.1 Load the Air Lock with samples, materials, supplies, etc.
- 13.2 Close the outer and inner Air Lock Doors.
- 13.3 Activate the Air Lock by one of two methods:
- A) **Manual Cycle (Manual Gas/Vacuum Switch):**
 - i. Locate the 3 position Manual Gas/Vacuum Cycling Switch which should be in the middle OFF position.
 - ii. Turn the Manual **GAS/VAC** switch to **VAC** until a vacuum of 17 to 20-in. Hg (42 to 50 cm. Hg.) is reached, as indicated by the **VACUUM GAUGE**.

-
- iii. Flip the **GAS/VAC** switch to **GAS** to refill the Air Lock with the gas mixture until the AIR LOCK VACUUM GAUGE reads approximately 4 in. Hg. (10 cm. Hg.) on the first two cycles. On the third and last cycle leave the gas on until the gauge reaches zero to ensure that there is no vacuum still present in the Air Lock, and then return the switch to the middle or OFF position.
 - iv. It is essential to perform the cycle at least three times. Once this is done, you may enter the chamber through the arm ports, using the procedure specified in the next section, and take your materials into the chamber through the Inner Air Lock door.

NOTE: When cycling the Air Lock manually, the AUTO CYCLE ANAEROBIC light on the control panel will not illuminate when the cycle is completed, as it does at the end of the automatic cycle.

B) Automatic Cycle:

- i. Make sure both Air Lock doors are closed. The automatic cycle will not start otherwise.
- ii. Press the “**AUTO CYCLE START/RESET**” button to initiate the cycle. The **AUTO CYCLE AEROBIC/AUTO CYCLE ANAEROBIC** lights will alternately flash on and off, indicating the cycle is in progress. When the cycle is complete, the system will stop automatically with the **AUTO CYCLE ANAEROBIC** light on.
- iii. If the cycle does not follow the sequences in the previous section on manual operation (e.g.: cycle won't start, cycle does not go through three (3) times, cycle out within specified limits, door won't open upon completion, etc.), consult the Troubleshooting Guide for adjustments.
NOTE: Do not hold Auto Cycle Start Switch down. Simply press the button and let go to activate.
- iv. If you want to abort the cycle, *press and hold* the “**AUTO CYCLE START/RESET**” switch for **5 seconds**. The vacuum gauge will go to **0** and **stop**. Then the **AUTO CYCLE AEROBIC/AUTO CYCLE ANAEROBIC** light will stop flashing.

14.0 ENTERING THE CHAMBER

- 14.2 The rubber cuffs of the sleeve should be secured around your arm as opposed to clothing. Remove watches, bracelets, etc., as they may damage the cuffs.
- 14.3 Insert your hands and forearms into the sleeves. The cuffs must be firmly secured around your bare forearms. Keep your hands four to six (4-6) inches away from the arm port doors.
- 14.4 Depress the VAC foot pedal (this procedure evacuated both sleeves), and continue depressing until the sleeves have collapsed completely and firmly around your forearms.
- 14.5 Flush the sleeves with the gas mixture by depressing the GAS foot pedal. Do not overfill the sleeves. Stop when you feel a small separation of space between your hands and the sleeves.
- 14.6 Repeat steps 14.3 – 14.4 three more times to ensure that the sleeves are completely anaerobic/desired atmosphere before entering the chamber.

NOTE: ALWAYS enter the chamber with both arms simultaneously.

- 14.7 Loosen the arm port door knobs a few turns and rotate the locking bars to a horizontal position. The arm port doors can now be pushed forward into the chamber interior and can be secured on the arm port door holders.

NOTE: Arm movements that are too forceful may cause the sleeves to dislodge from the arm ports.

15.0 EXITING THE CHAMBER

- 15.2 Before leaving the chamber the incubator doors and the inner Air Lock door must be closed.
- 15.3 Depress the GAS foot pedal to allow the sleeves to fill with gas. This procedure keeps the sleeves from collapsing as you move outward, making it easier to reposition the doors.
- 15.4 Hold the locking bars in a horizontal position, and close the doors. Rotate the locking bars to a vertical position, and gently tighten both arm port door knobs, just until they “grab”.
- 15.5 Before removing arms from the sleeves:
 - A) Check to be sure that arm port doors are securely sealed by slowly pushing both arms forward (this action generates a pressure within the sleeves).

-
- B)** If the Manometer bubbles when the arms are pushed forward, this indicates that the doors are improperly sealed. Loosen the arm port door knobs again and remove the doors. Check the O-rings for any particulate matter on the sealing areas and repeat Step A. If Manometer remains stable, the doors are sealed properly.

- 15.6** When the arm port doors are properly sealed, slowly and carefully withdraw both arms from the sleeves.

16.0 MAINTENANCE

DAILY/ROUTINELY:

- 16.1** Before using any cleaning or decontamination method except those recommended by the manufacturer, users should check with the manufacturer that the proposed method will not damage the equipment.
- 16.2** Exchange chamber catalyst cartridge with reactivated one.
- 16.3** Remove and empty condensate collection container.
- 16.4** Change oxygen indicators.
- 16.5** Disinfect the chamber interior. Do not use alcohol based cleaning products on the Plexiglas.
- 16.6** Check the cuffs on the sleeve system. If the cuffs have holes or any tears, replace.
- 16.7** Check incubator temperature.
- 16.8** Record gas tank reading.
- 16.9** Change/Rejuvenate Anatox.
Anatox absorbs volatile fatty acids and hydrogen sulfide in the chamber. Recommended use is 250 grams placed in a beaker in the chamber.
Anatox-1000 grams (packaged in 250 gram packages)

Instructions:

- A.** Empty two (2) 250 gram packages into two (2) separate 500 ml Pyrex beakers.
- B.** Day *one* – place one beaker in the chamber (new Anatox can be placed directly into the chamber).
- C.** Day *two* – remove beaker in the chamber and replace with the second beaker of Anatox (also new).
- D.** Day *three* – reactivate the first beaker of Anatox by heating at 160°C for 2 hours. Then replace the beaker in the chamber with this reactivated beaker.
- E.** Day *four* – *six months* – continue switching the reactivated beakers daily until six months is complete, then discard the old Anatox and repeat the procedure again.

17.0 CHECKLIST

CHAMBER QC SHEET

Month					
	Record Temperature	Change Catalyst	Change Indicator	Drain Condensate	Record Tank Pressure Gauge Reading
Date					
1					
2					
3					
4					
5					
6					
7					
8					
9					
10					
11					
12					
13					
14					
15					
16					
17					
18					
19					
20					
21					
22					
23					
24					
25					
26					
27					
28					
29					
30					
31					

18.0 ACCESSORIES

Tank Switch Model # 2002-B

Switches and monitors dual gas tank supply. Provides automatic switch-over to second gas tank alarm sounds when both tanks are empty. Tanks can be switched manually at any time.

Nitrogen Gas Regulator

Optional accessory used in a two gas chamber
Part # 7150500

Extended Service Contracts

The contract offers a twelve month warranty on parts and labor. Ensures customer of product satisfaction and optimal performance.

Cleaner

Benzalkonium Chloride

Recommended using in Manometer.
Part # 1060501

Anatox

#B90010 From Anaerobe Systems Co.

Acrylic Glass Cleaner

#1060503-8 oz size

Acrylic Glass Scratch Remover

#1060504-8 oz size

Chamber Stand

Provides work bench to support Bactron chambers. Chamber Stand height 30". Stands feature locking casters and storage space:

BAC1-STAND

BAC2-STAND

BAC4-STAND

**Model: BACTRONEZ BACTRONEZ-2
BACTRON300/BACTRON300-2
BACTRON600/BACTRON600-2**

Microscope Recommendation

The LEICA brand of microscope is a commonly used unit with Bactron System.

Microscope: #9990516

Illuminator: # 4650549

Spare Lamp: # 4650504

PARTS

<u>Catalog No.</u>	<u>Product</u>
9900706	Indicator Strips
9990759	Catalyst Holder Filled
5110729	Petri-Plate Rack 2x13
	Sleeves, Complete
	Small
	Medium
	Large
	LED Light Box
	Start Up Kit
9490512	<i>BACTRONEZ/BACTRONEZ-2</i>
	Start Up Kit
9490511	<i>BACTRON300/BACTRON300-2 BACTRON600/BACTRON600-2</i>
3600500	Rubber Cuffs, Sm Size 7
3600501	Rubber Cuffs, Med Size 8
3600502	Rubber Cuffs, Lrg Size 9
6000501	O-Ring For Door
6000504	O-Ring For Cuff
	Gasket-Airlock 9 x 9
3450506	<i>BACTRONEZ/BACTRONEZ-2 BACTRON300/BACTRON300-2</i>
	Gasket Airlock 12 x 12
3450507	<i>BACTRON300/BACTRON300-2 BACTRON600/BACTRON600-2</i>
3600525	Nitril Cuffs-Size 7
3600526	Nitril Cuffs-Size 8
3600527	Nitril Cuffs-Size 9
9990753	Butadyl Sleeve Assy
9990707	Neoprene Sleeve Assy

19.0 CHAMBER SYSTEM DRAWINGS

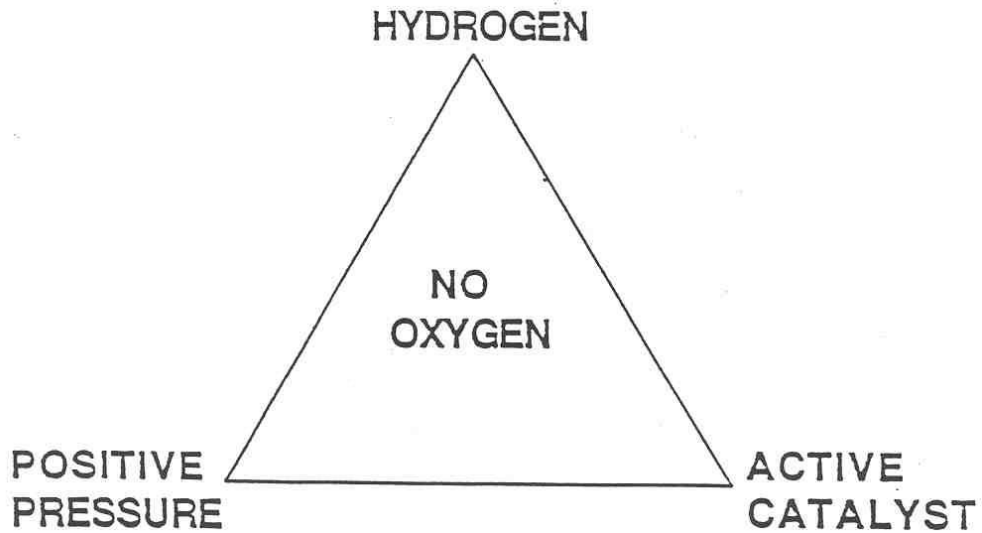

Gas

Anaerobic mixture is 5% hydrogen, 5% carbon Dioxide, and 90% nitrogen. Do not exceed 5% hydrogen for safety reasons. Test for the presence of hydrogen in the gas mixture by flowing the gas over the active catalyst. The catalyst will get hot if hydrogen is present.

Catalyst

Reactive by heating for two (2) hours at 160° C. Test by flowing the anaerobic gas mixture over the catalyst. If the catalyst is active, it will get hot. The catalyst can be "cleaned" by heating to 200°C, then flowing the anaerobic gas mixture over the catalyst.

Positive Pressure

The Manometer will indicate if positive pressure is present in the chamber.

SYSTEM CONTROLLER AND CONTROLS: VIEW FROM BEHIND PANEL (9850802)

ITEM	DESCRIPTION	PART#
1	SYSTEM PROGRAM CONTROLLER	1750621
2	POWER SUPPLY	6750507
3	VACUUM SOLENOID	8600809
4	CHAMBER GAS SOLENOID	8600528
5	WORKING GAS SOLENOID	8600528
6	ROUGHING GAS SOLENIOD	8600528
7	SOLID STATE RELAY	102162
8	CHAMBER PRESSURE SWITCH	9740559
9	THERMOELECTRIC COOLER	1070502
10	DIGITAL VACUUM GAUGE/SW	7850552

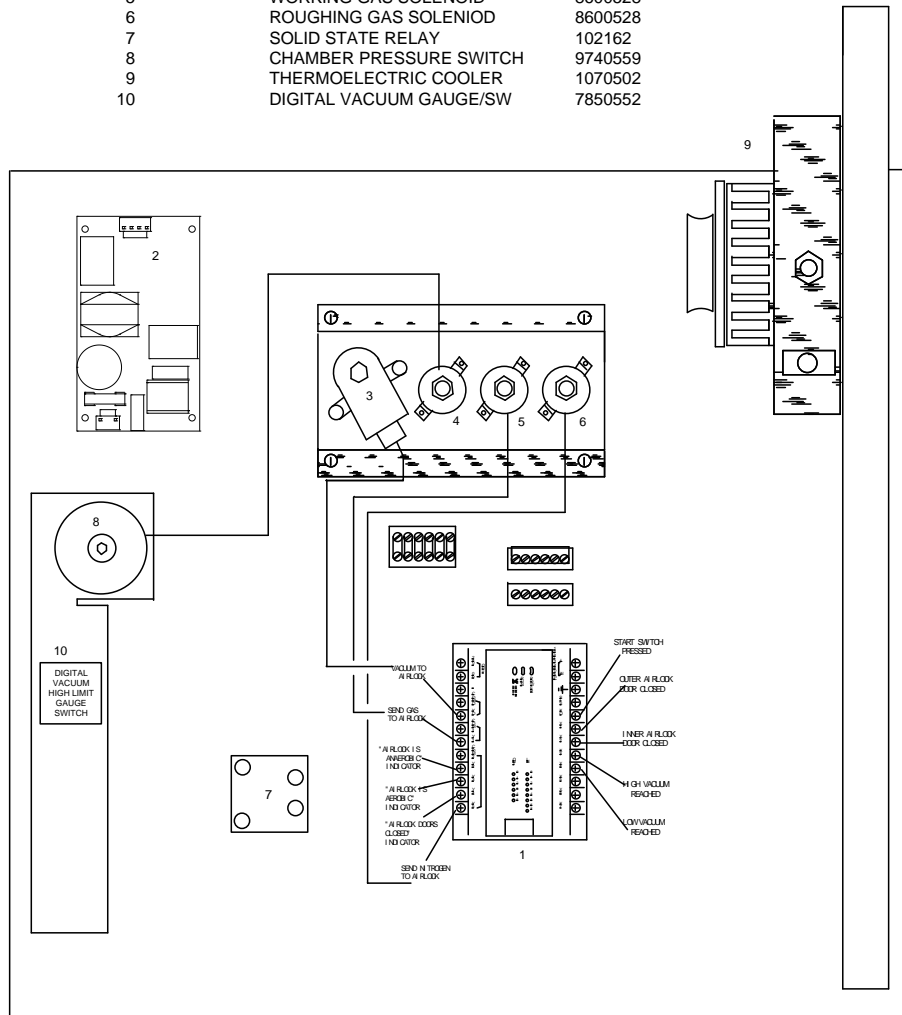

9850802
 dlr 4/16/09 rev
 Rmh 7/17/12 rev
 Rmh 7/19/12 rev

SOLENOID

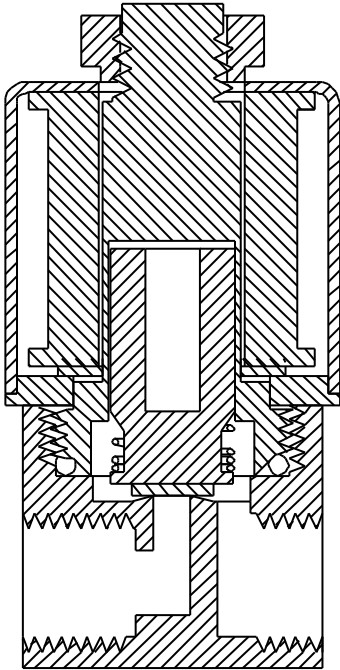
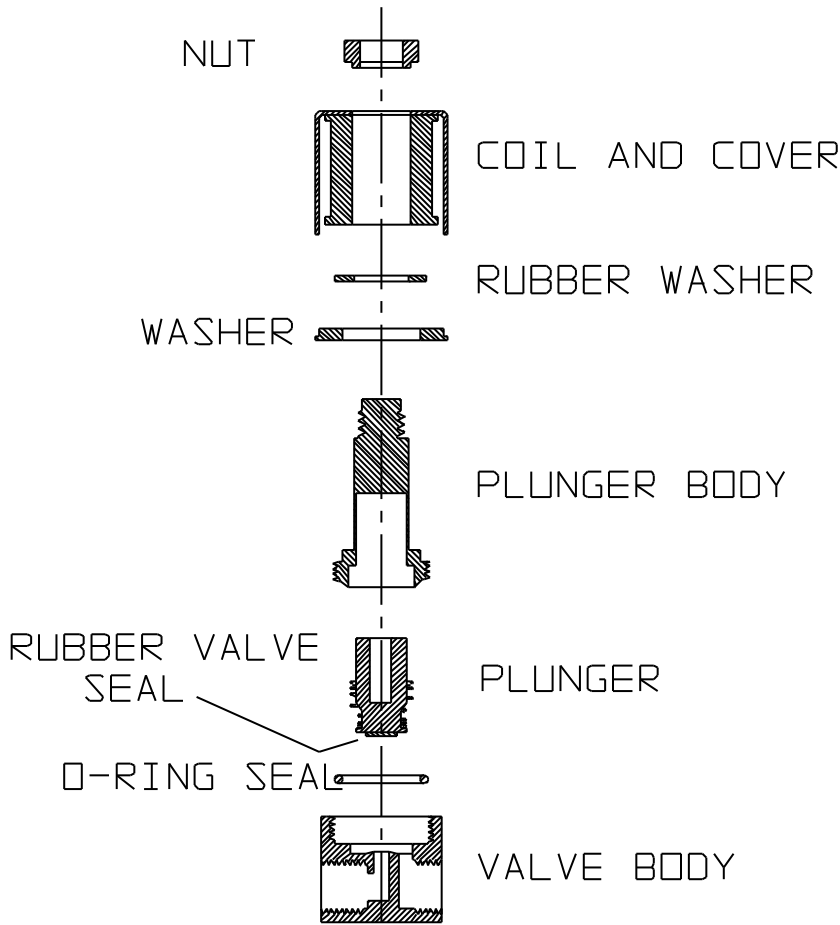

J:\0100000\100016EX.PLT

System Controller Indicator Guide

	Function	At Rest	Start	Vacuuming	High Vacuum	Gassing	Low Vacuum	Completed
		<i>No action. Both doors closed.</i>	<i>Start button pressed.*</i>	<i>Vacuum on. Vacuum Going up.</i>	<i>Switch Point Reached</i>	<i>Gas on. Vacuum going down</i>	<i>Switch Point Reached</i>	<i>Airlock anaerobic</i>
		Airlock aerobic.	Lights flashing	Lights Flashing		Lights flashing		

Inputs

x0	Start	Off	On *	Off	Off	Off	Off	Off
x1	Outer Door	On	On	On	On	On	On	On
x2	Inner Door	On	On	On	On	On	On	On
x3	High Vacuum	On	On	On	Off **	On	On	On
x4	Low Vacuum	On	On to Off	Off	Off	Off	On	On
X7	Chamber Gassing	On/Off ***	On/Off ***	On/Off ***	On/Off ***	On/Off ***	On/Off ***	On/Off ***

Output

y0	Vacuum Solenoid	Off	On	On	On to Off	Off	Off to On	Off
y1	Gas (AMG) Solenoid	Off	Off	Off	Off to On (1)	On (1)	On to Off (1)	Off
y2	Anaerobic Light	Off	Flashing	Flashing	Flashing	Flashing	Flashing	On
y3	Aerobic Light	On	Flashing	Flashing	Flashing	Flashing	Flashing	Off
y4	Door Light	On	On	On	On	On	On	On
y5	Nitrogen**	Off	Off	Off	Off to On (2)	On (2)	On to Off (2)	Off
Y6	Chamber Gas Solenoid	Off (3)	Off (3)	Off (3)	Off (3)	Off (3)	Off (3)	Off (3)

*Input 0 is only when the start button is pushed

** Input 3 comes on only for a short moment

(1) Gas comes on for the last cycle only.

(2) Nitrogen comes on for the first two cycles.

(3) Chamber Gas Solenoid only active when working chamber is gassing. Active while input x7 is On

CAUTION: *Extreme caution must be exercised any time access is made into areas housing electrical components. Repair, replacement or adjustment of components in these areas must only be done by qualified technicians familiar with electrical circuitry and the operation of the anaerobic chamber.*

ATTENTION: Des Précautions extrêmes sont requises à chaque fois que vous accédez à des endroits qui abritent les composantes électriques. La réparation, le remplacement ou l'ajustement de composantes dans ces endroits ne doivent être effectués que par un technicien qualifié familier avec les circuits électriques et l'opération des étuves anaérobiques.

20.0 Troubleshooting

General Troubleshooting Guide

I. GAS CONSUMPTION

PROBLEM	POSSIBLE CAUSE	SOLUTION
<p>CHAMBER GASSING</p> <p>Light comes on every five (5) minutes or less</p>	<p>A. Armport door not sealing.</p> <p>B. Leak in seams.</p> <p>C. Manometer leak, indicated by very large leak out manometer hole. (Confirm with soap solution)</p> <p>D. Oxygen present-hydrogen being consumed by combining with oxygen.</p>	<p>A. Tighten knob until it "grabs", Check for worn O-rings.</p> <p>B. Check front acrylic glass panel with leak detector. Call for service.</p> <p>C. Seal inner tube to block, and block to mounting plate with solvent cement.</p> <p>D. No action necessary.</p>
<p>CHAMBER GASSING</p> <p>Light comes on more often with the outer door open than with it closed</p>	<p>A. Inner door gasket not sealing-check with leak detector.</p>	<p>A. Check for worn gasket.</p>
<p>Chamber pressure Increase</p> <p>Manometer Bubbles</p> <p>CHAMBER GASSING light on.</p>	<p>A. Chamber pressure sensor switch stuck in "on" position.</p> <p>B. Pressure set too high. Adjust pressure sensor.</p>	<p>A. Tap switch to jar contacts loose, then replace switch.</p> <p>B. Turn adjustment screw counter-clockwise to decrease pressure.</p>
<p>Excessive gas usage - no chamber leaks</p>	<p>A. Foot pedal leaking.</p> <p>B. Gas regulator/gas input connections leaking.</p> <p>C. Leak in supply line.</p>	<p>A. Disassemble and clean GAS valve or replace.</p> <p>B. Check for and repair any leaks. Check regulator for 15-20 psi maximum output.</p> <p>C. Check all gas lines for leaks.</p>

Chamber pressure increases or Manometer bubbles. CHAMBER GASSING light off.	A. Chamber gassing Solenoid leaking, inlet gas pressure normal. Pinch hose to chamber to see that bubbling stops.	A. Disassemble and clean or replace solenoid valve if necessary.
	B. Chamber gassing solenoid leaking, inlet gas pressure too high.	B. Set inlet gas pressure to 15-20 psi.
	C. Chamber gassing solenoid hoses incorrectly.	C. See Hose Connections Diagram.
	D. Air Lock gas solenoid leaks. Pinch hose to module, see if it stops.	D. Disassemble and clean or replace solenoid valve.
	E. Incubator temperature increase on startup.	E. No action necessary.

II. AEROBIC CHAMBER CONDITIONS

Problem	Possible Cause	Solution
Indicator strips are Activated. (i.e. turn color).	A. Low chamber pressure.	A. Adjust chamber pressure sensor by turning clockwise to increase.
	B. Catalyst inactive.	B1. Use freshly heated catalyst, flush chamber with approx. 50 to 100 psig of gas depending on how long chamber has been aerobic and size of chamber
		B2. Check to see that gas makes catalyst hot. If not, heat to 200 C and blow gas mix through to remove sulfide layer.
	C. Circulating blower not functioning.	C. Replace fan.
	D. Air lock not evacuating to high enough vacuum (17-18 in. Hg., 42-46 cm. Hg.).	D. Turn High side switch clockwise to increase.
	E. Outer Air Lock door not sealing properly.	E. Check for damaged gasket, replace if necessary.
	F. User did not perform sleeve technique properly upon entering chamber.	F. Check technique of all chamber users.
G. Gas tank mixture contains an insufficient concentration of Hydrogen.	G1. Check for very low or empty tank.	
	G2. Check label for at least 5% Hydrogen.	

General Troubleshooting Guide Continued

III. AIR LOCK

Problem	Possible Cause	Solution
Air Lock does not hold Vacuum.	<p>A. Split gasket inner & outer door.</p> <p>B. Inlet fitting to module not sealed.</p> <p>C. Vacuum solenoid leaking Pinch hose to module and see if leak stops.</p> <p>D. Defective vacuum switch.</p>	<p>A. Check gasket. If split, replace.</p> <p>B. Tighten/reseal with teflon tape if necessary.</p> <p>C. Disassemble and clean solenoid - replace if necessary. WD40 can be used to clean solenoid.</p> <p>D Replace switch.</p>
Automatic cycle will not start.	<p>A. Make sure both doors are closed. Door sensors not making contact-check that DOORS light is ON. If not, check programmable Controller input display IN 0001 (outer door) and IN 0002 (inner door) should be on.</p> <p>B. Start button inoperative - check input display - IN0000 should be on when start button is pushed, OFF when not.</p> <p>C. No power to controller - check power light on Controller.</p>	<p>A. Adjust location of the door sensor so that DOORS light is on when both doors are closed.</p> <p>B. Replace start button.</p> <p>C1. Check for 24 volt DC out of power supply.</p> <p>C2. Check for continuity between power supply and controller.</p>
Chamber pressure goes down when cycle is started. (Manometer level rises)	<p>A. Inner door gasket not making proper seal.</p>	<p>A. Replace door gasket if necessary</p>
Cycle only goes through two cycles.	<p>A. System Controller Malfunction.</p>	<p>A. Replace System Controller.</p>
Switch will not go from Vacuum to Gas in Auto Cycle.	<p>A. Insufficient vacuum supply.</p> <p>B. High vacuum set point too high, it should be around 17-18 in. Hg., 42-46 cm. Hg.</p>	<p>A. Adjust switch on VAC pump to allow higher vacuum before shut off, around 20 in. Hg., 50 cm. Hg.</p> <p>B. Turn High side switch counter-clockwise to decrease.</p>
Doors difficult to open upon completion of cycle.	<p>A. Low vacuum set point too high.</p>	<p>A. Turn Low side switch Counter clockwise to Decrease.</p>

General Troubleshooting Guide Continued

IV. INCUBATOR

Problem	Possible Cause	Solution
Steady digital readout matches set point, but actual temperature does not.	A. Temperature Controller out of calibration. B. Incubator door open.	A. Follow Complete Temperature Controller instruction. B. Close incubator door and allow incubator to stabilize.
Digital readout and actual temperature continue to increase past set point.	A. Output relay stuck - Check to see if "Incubator Heating" Indicator light stays on while temperature is Increasing. B. Incubator door open.	A. Replace Temperature Controller. B. Close incubator door and allow incubator to stabilize.
Audible alarm sounds.	A. Temperature has risen beyond the set range for the High Limit Safety.	A. Determine cause of temperature increase from prior section and take appropriate action. Call for service.

V. VACUUM PUMP

Problem	Possible Cause	Solution
Pump continually turns on off in rapid succession. Ideally, pump should remain off for 30 minutes or more before coming on again.	A. Leaking check valve - Normally due to debris between poppet and O-ring seal. B. Vacuum foot pedal valve may be leaking. Check to see if pinching its hose stops problem. C. Leak in pump plumbing - pipe fitting switch, hose, etc. D. Air Lock vacuum solenoid leaking.	A. Disassemble check valve clean off any debris from poppet, O-ring, reassemble. B. Remove hose barbs from valve - there may be some debris holding valve open. Replace valve if necessary. C. Tighten any loose fittings, check hoses for cuts, holes, leaks around hose barbs. D1. Disassemble solenoid, clean plunger, O-ring spring, etc. and reassemble. D2. Make sure vacuum hose from pump is not pinched.
Vacuum motor does turn on.	A. Broken vanes in Pumping Section (the end of pump with filter jars). B. Electrical problem with Motor. C. Check pump power supply	A. Remove the end of the pump and replace any broken vanes. B. Replace pump. C. Check circuit breaker on back of chamber.
Pump runs continuously when there is no demand for vacuum.	A. Set point on pump Vacuum switch set too high.	A. See "Setting Vacuum High Switch".

General Troubleshooting Guide Continued

VI. MISCELLANEOUS

Problem	Possible Cause	Solution
Excessive moisture buildup in chamber.	<p>A. Thermoelectric condensate controller fan is not operating.</p> <p>B. Ambient room temperature too low.</p> <p>C. Air conditioner unit directly above chamber.</p> <p>D. Thermoelectric condensate controller not emptied regularly.</p>	<p>A. Replace fan.</p> <p>B1. Maintain room temperature a bit higher.</p> <p>B2. Cover chamber with a blanket overnight as means of installation.</p> <p>C. Relocate chamber, redirect the air conditioning duct.</p> <p>D. Empty thermoelectric condensate controller container.</p>
Loop sterilizer does not work.	<p>A. Loop covered with oxidized layer which insulates from power supply.</p> <p>B. Sterilizer unit not getting power.</p>	<p>A. Use a new loop.</p> <p>B1. See that the unit is Plugged into internal Outlet.</p> <p>B2. See that the internal outlet is getting power.</p> <p>B3. Replace.</p>

21.0 BACTRON OPERATION TIPS

<p>Keeping the Bactron Chamber Anaerobic:</p>	<p>The Bactron chamber will be anaerobic if it has the following three things: Hydrogen, Positive Pressure, and an Active Catalyst.</p> <p>User should place oxygen indicators inside the chamber or an oxygen meter to ensure that they have an anaerobic environment. One indicator should be placed inside the working chamber and another in the incubator. The indicators turn color in the presence of oxygen, and are available through distributors and supply companies.</p> <p>If the indicators change to <i>pink</i>, purge the chamber with 100 PSI and wait for 30 minutes. The open a new indicator. If the new indicator is <i>white</i> in color your chamber in anaerobic. The greater the color of the indicator, the more gas to purge through the chamber and the longer users should wait before re-checking system.</p>
<p>Gas Source:</p>	<p>Sheldon Manufacturing, Inc. recommends an AMG, Anaerobic Mixed Gas, mixture of 5% CO₂, 5% Hydrogen, and 90% Nitrogen for anaerobic applications.</p> <p>This mixture is available marked “NON-FLAMMABLE”.</p> <p>Two national sources of AMG gas are AIRCO and Air Products.</p>
<p>Methods to Conserve Gas:</p>	<p>Users can utilize the Air Lock as a holding station. As samples are received they can be stored in an anaerobic environment by placing them in the Air Lock and activating either the automatic or manual Air Lock cycle.</p> <ol style="list-style-type: none"> 1. Users should evaluate and try to limit the number of times the Air Lock is opened. For example, placing samples in the Air Lock once in the morning and once in the afternoon as opposed to four times a day is desirable. 2. Gas is also conserved by bringing samples in through the sleeve system. Easy samples to transport through the sleeves are transport tubes as well as plates that are sealed. 3. Placing an object in the Air Lock will reduce the amount of cubic area therefore reducing the amount of atmosphere exchanged and gas utilized. 4. Good sleeve system technique. During the first vacuum cycle, remove all the atmosphere from the sleeve. Users should be able to see the outline of their fingers. Bring enough gas in to the sleeve (by pressing the GAS foot pedal) as to eliminate the definition of the fingers or when the sleeve is nor clinging to the arm. Users should not “balloon” the sleeve out when flushing with gas. This action will waste gas. 5. The bubbling of the manometer and the activation of the “chamber gassing” indicator light on the control panel notifies the user of usage will working in the chamber. <p>When a user is in the “Working Area” they should be aware of the effects their movements have on gas consumption.</p> <p>Gas consumption can be reduced by balancing arm movements. For example, when extending the right arm into the chamber, bring the left arm close to the front of the chamber, thus balancing the pressure and reducing gas displaced by area.</p>
<p>Aborting Auto-Cycle:</p>	<p>The automatic Air Lock can be aborted by pressing and holding the “Auto Start/Reset” button for five (5) seconds. If a user forgets to place a sample in the Air Lock the cycle can be aborted in order to eliminate the unnecessary use of gas.</p>
<p>How much does AMG gas cost?</p>	<p>The price that a gas supplier charges is often determined by the amount of the gas the customer uses. The price per tank will decrease as the</p>

	<p>quantity ordered decreases.</p> <p>Sheldon recommends that customers get competitive bids on their gas to ensure that they are receiving the “best” market price.</p>
Dual Gas Systems:	<p>The Bactron product line comes standard with the capability to operate a chamber with a single gas or a dual gas system. This is an exclusive feature that provides customer flexibility.</p> <p>Refer to the Instruction Manual “Gas Connections” for installation details.</p> <p>A dual gas system, the nitrogen gas is utilized in the first two flushes of the automatic cycle of the Air Lock. The third and final flush is AMG gas. The sleeve system always utilizes AMG gas.</p> <p>Customers using a dual gas system need to have two regulators: An AMG regulator and a nitrogen regulator.</p>
Catalyst:	<p>Two catalyst cartridges containing palladium pellets are provided with the Bactron Chamber. The catalyst must be active in order to ensure an anaerobic environment.</p> <p>Customers need to place a reactivated catalyst in their chamber each day the chamber is used. The catalyst can be reactivated by heating for a minimum of 1-1/2 to 2 hours at 160° Celsius.</p> <p>The catalyst can be tested to ensure it is activated by flowing anaerobic gas over the pellets. If the pellets become warm or hot, they are working properly and are ready for use in the chamber.</p> <p>The catalyst can be “cleaned” by heating to 200° Celsius, then flowing the anaerobic gas mixture over the catalyst.</p>
Positive Pressure:	<p>If the chamber is installed properly and is connected to a gas supply the system will have positive pressure.</p> <p>The manometer provides users with a visual indication that they have positive pressure. When the manometer bubbles, for example when a user enters the chamber, it is releasing chamber atmosphere/pressure.</p>
Role of Condensate Controller:	<p>The Condensate Controller is an exclusive Bactron feature of Sheldon Manufacturing, Inc. Our competitors use desiccants. Desiccants are a drying agent and often dry out samples.</p> <p>The Condensate Controller ensures the following:</p> <ol style="list-style-type: none"> 1. Eliminates condensation in the chamber. 2. Samples will not dry out. 3. Chamber will not fog. <p>The Condensate Controller system is located on the left side of the chamber interior behind the catalyst cartridge. Excess moisture is drained into a tube for easy removal.</p> <p>Place a container (i.e. a flask or beaker) under the tube for collection. Customers should empty the container routinely.</p>
Chamber Checklist:	<p>It is recommended that customers review a checklist before they enter the Bactron Chamber. The checklist serves as a reminder of supplies and samples they need to bring into the unit.</p> <p>Common items listed on a checklist are: re-activated catalyst, samples and loops. The checklist can be placed on the front Acrylic glass panel.</p>

How to Determine if a Chamber is Leaking:	<p>Users should note the level of their gas tank(s) on a routine basis. This provides a way to monitor chamber gas consumption.</p> <p>Users can perform the following check before they exit the chamber through the sleeve system to ensure the chamber is closed properly. Upon closing the arm port doors and before removing arms from the sleeves, user should push on the sleeves. If the arm port doors are not closed properly, the manometer will bubble.</p>
Hand Held Leak Detector:	<p>If a chamber leak is suspected use the Hand Held Leak Detector provided to identify where the leak is located. The detector senses hydrocarbons, in our case hydrogen.</p> <p>Be aware that when using the leak detector, the manometer vent hole on the back of the chamber will activate the detector. This is because hydrogen is being released from the chamber through the manometer. To check the manometer for leaks, use a soap and water solution over the manometer and observe for bubbles.</p>
Amount of Water Collected in the Dehumidifier:	<p>The amount of water collected in the dehumidifier depends on the number and types of samples in the chamber. The typical amount collected is around 50 cc each day of chamber use.</p>
Size of Sleeve Cuffs:	<p>It is critical that the sleeve cuffs seal around the user's arm during chamber operation to ensure the desired anaerobic environment.</p> <p>The location that the cuffs seal on the user's arm is determined by individual preference.</p> <p>The size of the cuffs that come standard with the Bactron Chamber is medium, size 8 glove. Other sizes are available; large size 9, and small size 6 ½.</p>
Replacement of Cuffs:	<p>When and how often the cuffs on the sleeve need to be replaced depends on customer care and technique. Typically the cuffs are replaced about every three months.</p> <p>Customers should watch for small holes that can appear where the cuffs are placed on the "ring cuff". If holes are present the cuffs should be replaced to avoid gas leak. Watches and jewelry can damage the cuffs and are not recommended to be worn during chamber use.</p>

Electrical

Model	Volts	Amps	VA	Cycles
BACTRONEZ	110-120	8	1100	50/60 hz
BACTRONEZ-2	220-240	4	1100	50/60 hz
BACTRON300	110-120	8	1100	50/60 hz
BACTRON300-2	220-240	4	1100	50/60 hz
BACTRON600	110-120	11	1350	50/60 hz
BACTRON600-2	220-240	6	1350	50/60 hz

22.0 DIAGRAMS

CONTROL PANEL WIRING BACTRONEZ (BACTRONI) & BACTRON300 (BACTRONI) (9851408)

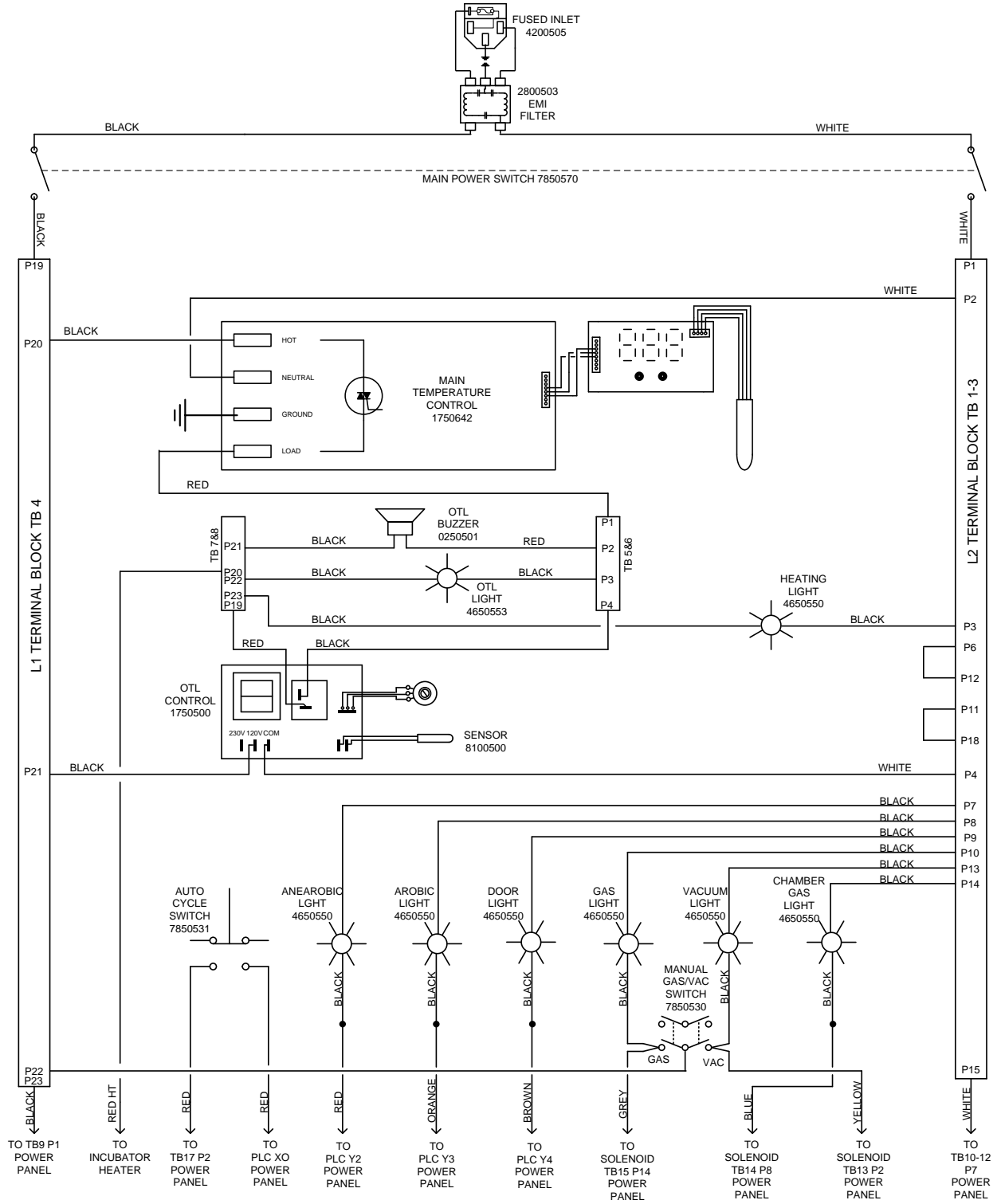

CONTROL PANEL WIRING BACTRON600 (BACTRONIV) (9851414)

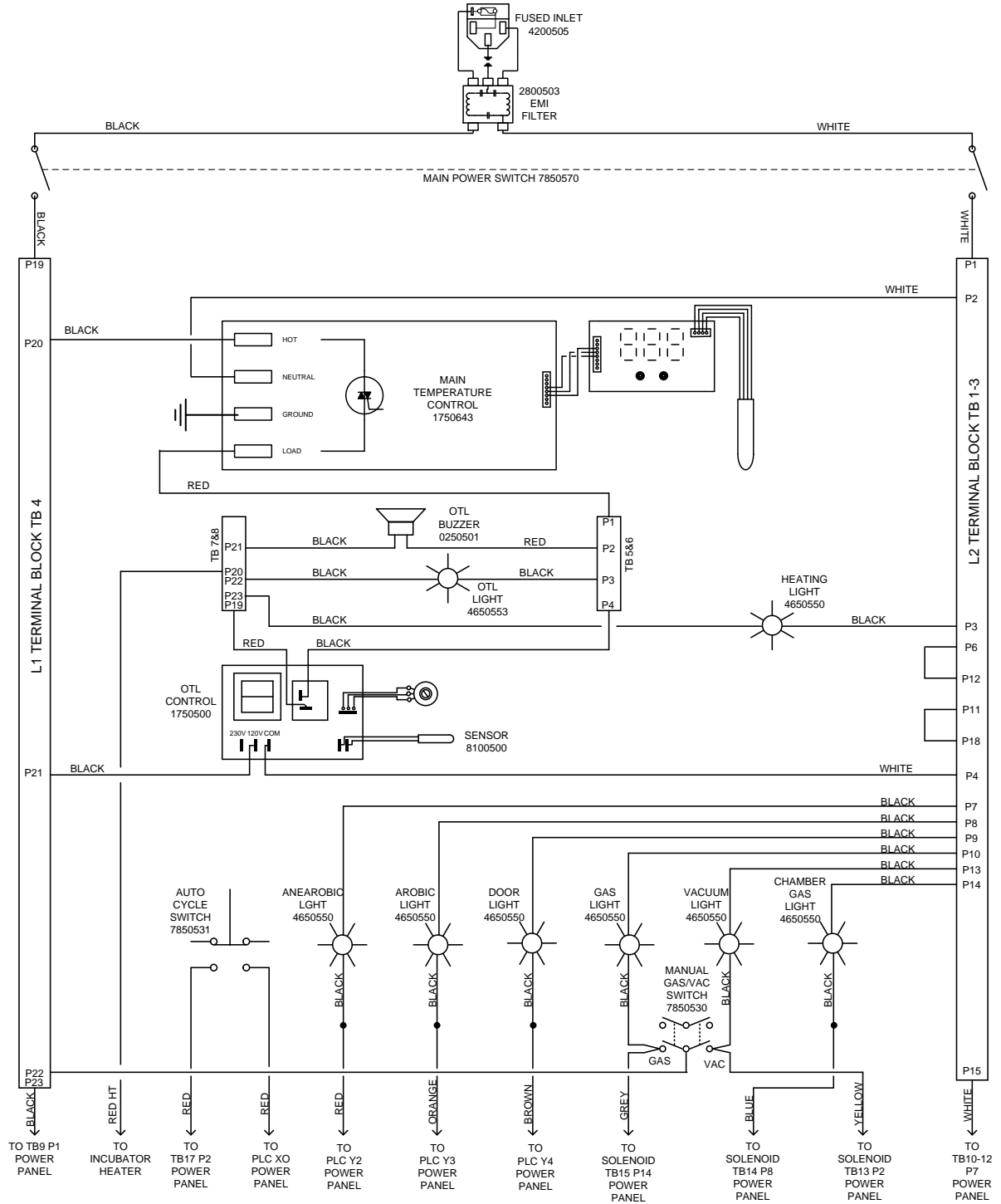

CONTROL PANEL WIRING BACTRONEZ-2 (BACTRONI-2) & BACTRON300-2 (BACTRONII-2) (9851410)

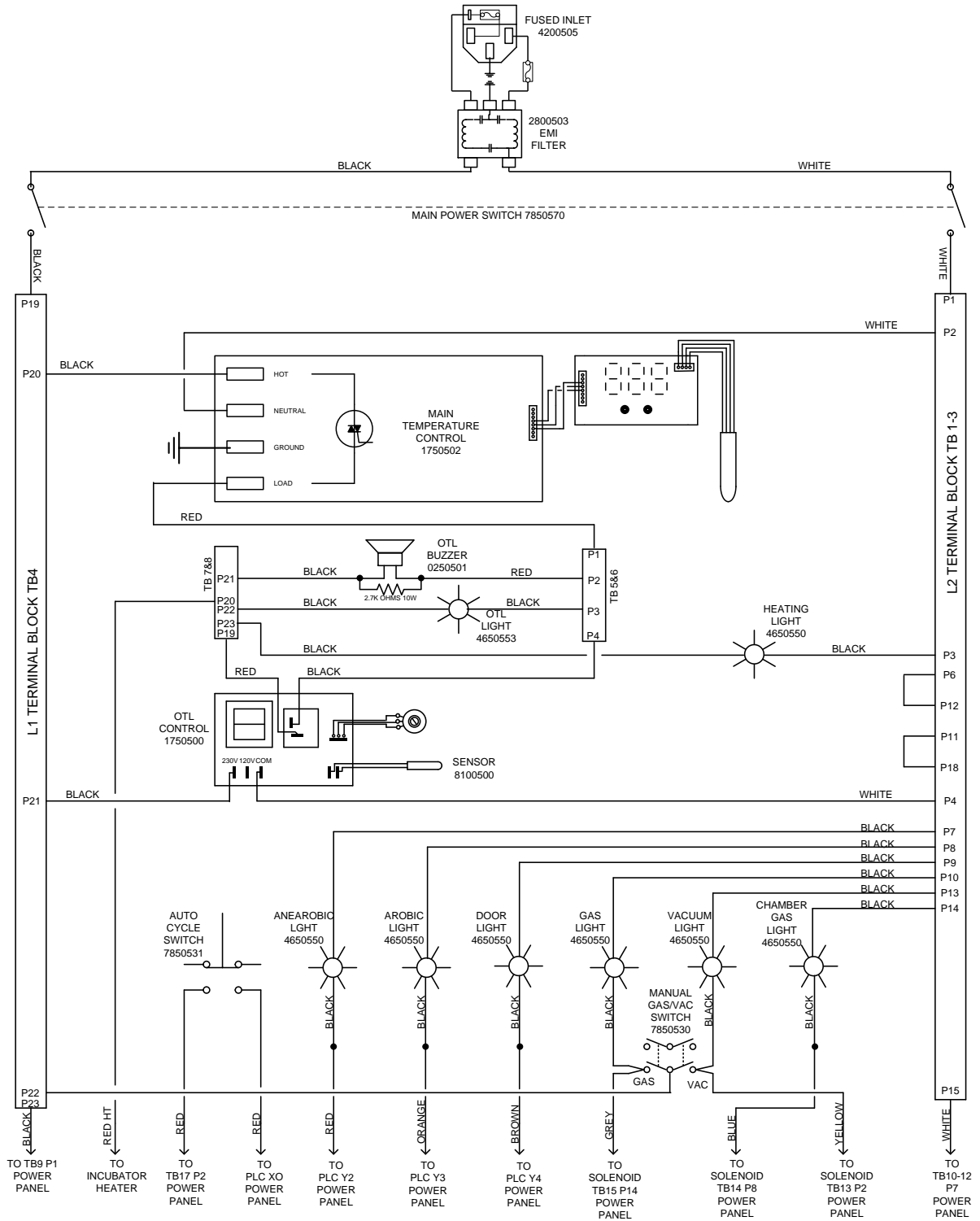

CONTROL PANEL WIRING BACTRON600-2 (BACTRONIV-2) (9851416)

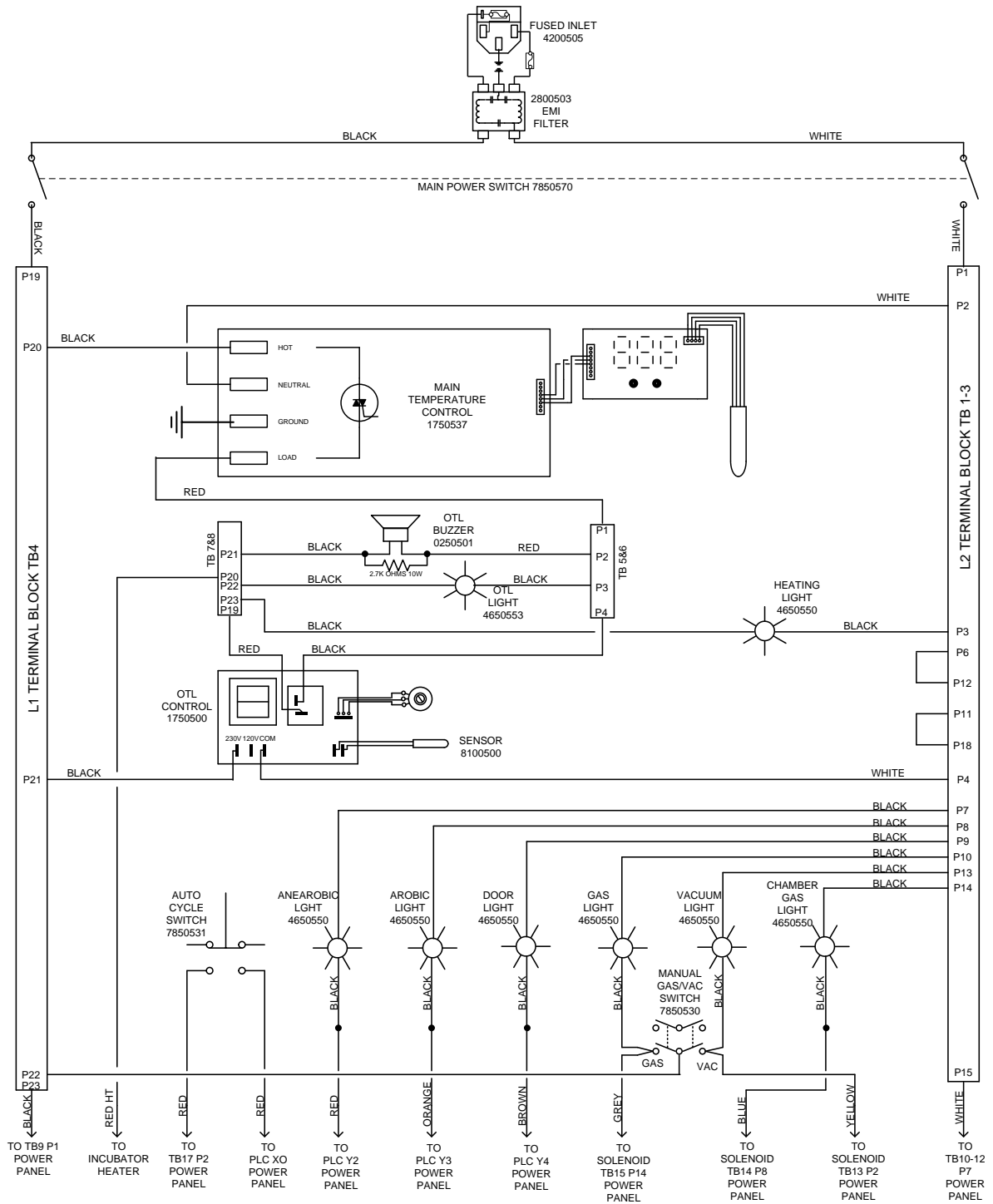

POWER PANEL WIRING BACTRONEZ (BACTRONI) & BACTRON300 (BACTRONI) (9851409)

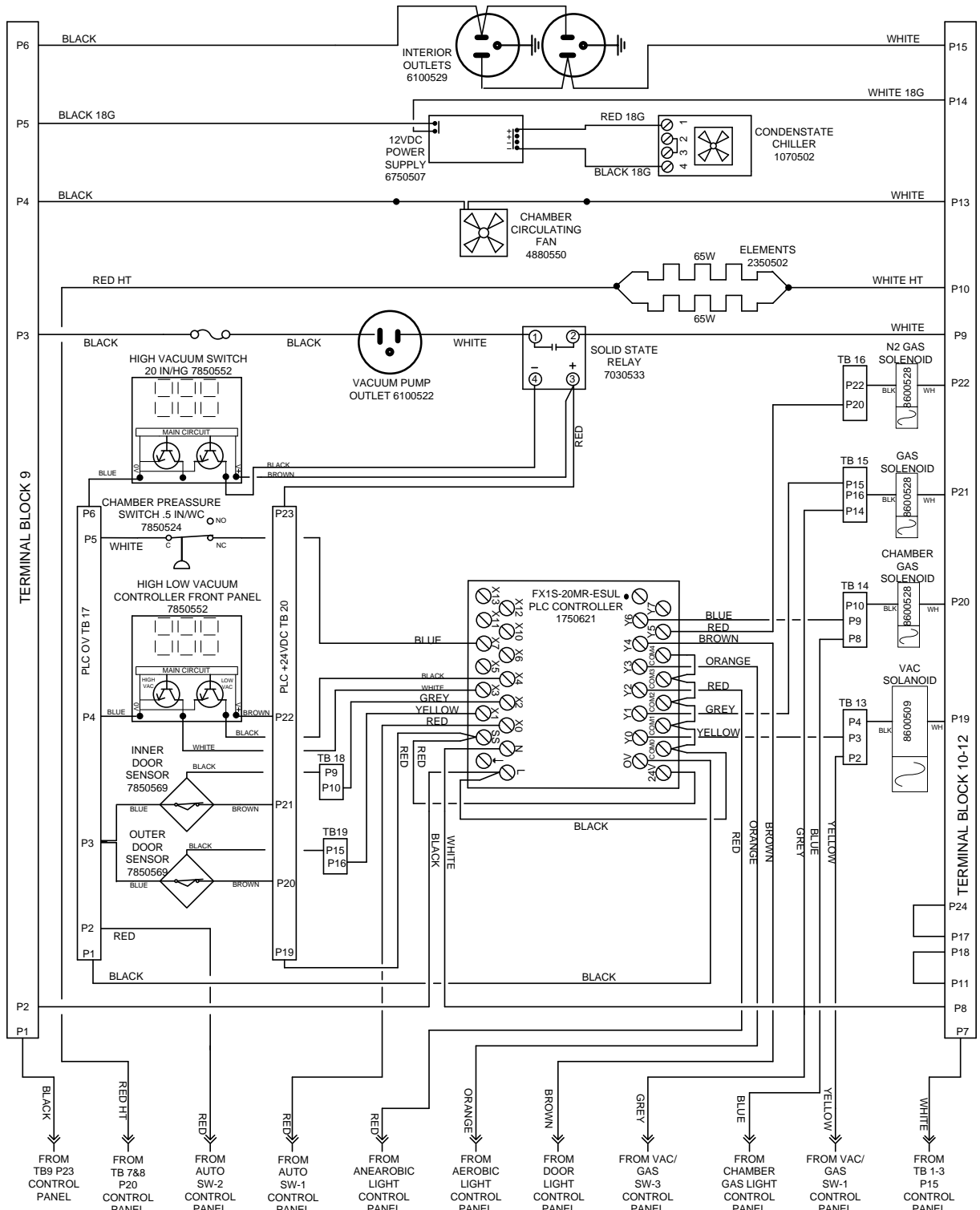

POWER PANEL WIRING BACTRON600 (BACTRONIV) (9851415)

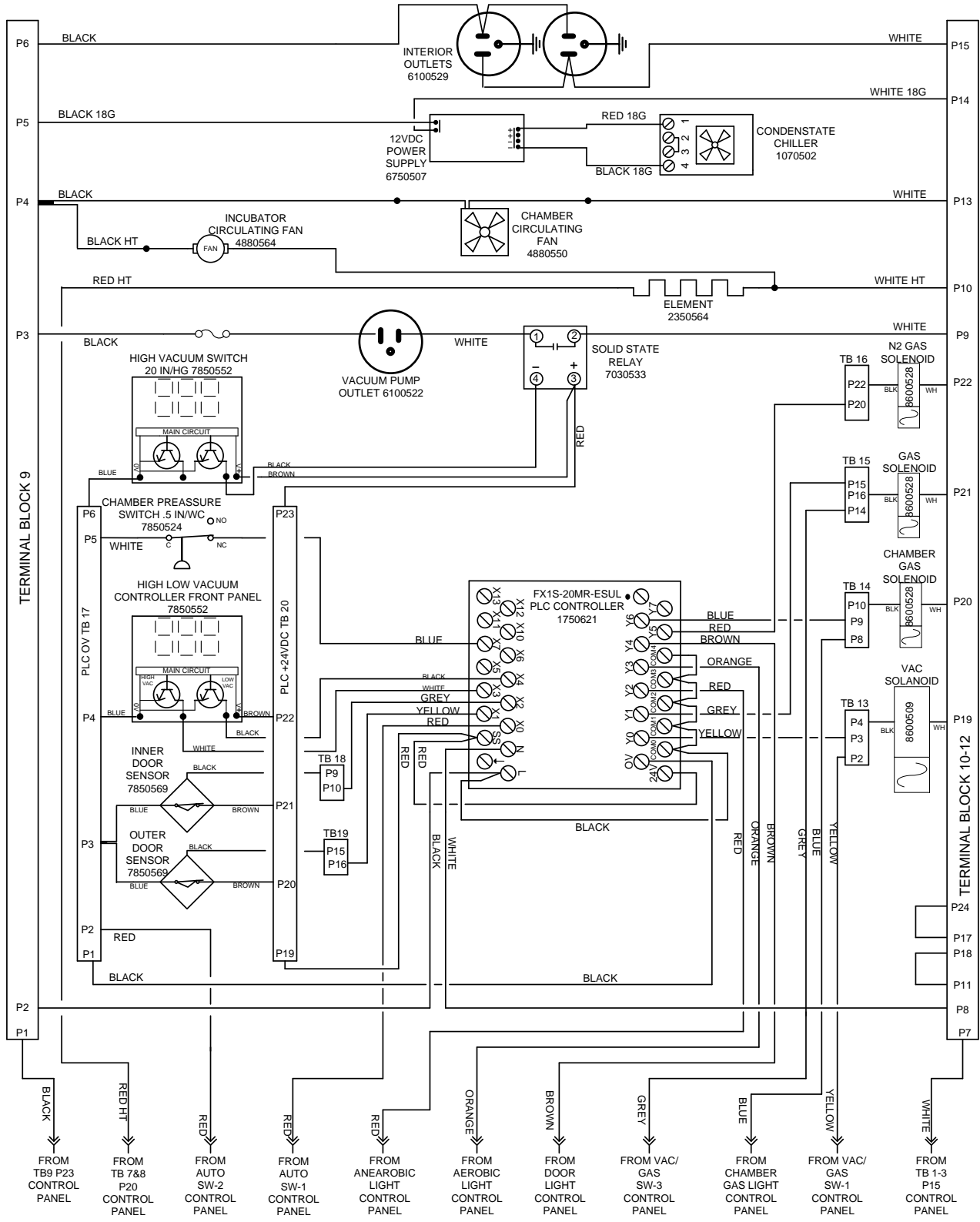

POWER PANEL WIRING BACTRONEZ-2 (BACTRONI-2) & BACTRON300-2 (BACTRONII-2) (9851411)

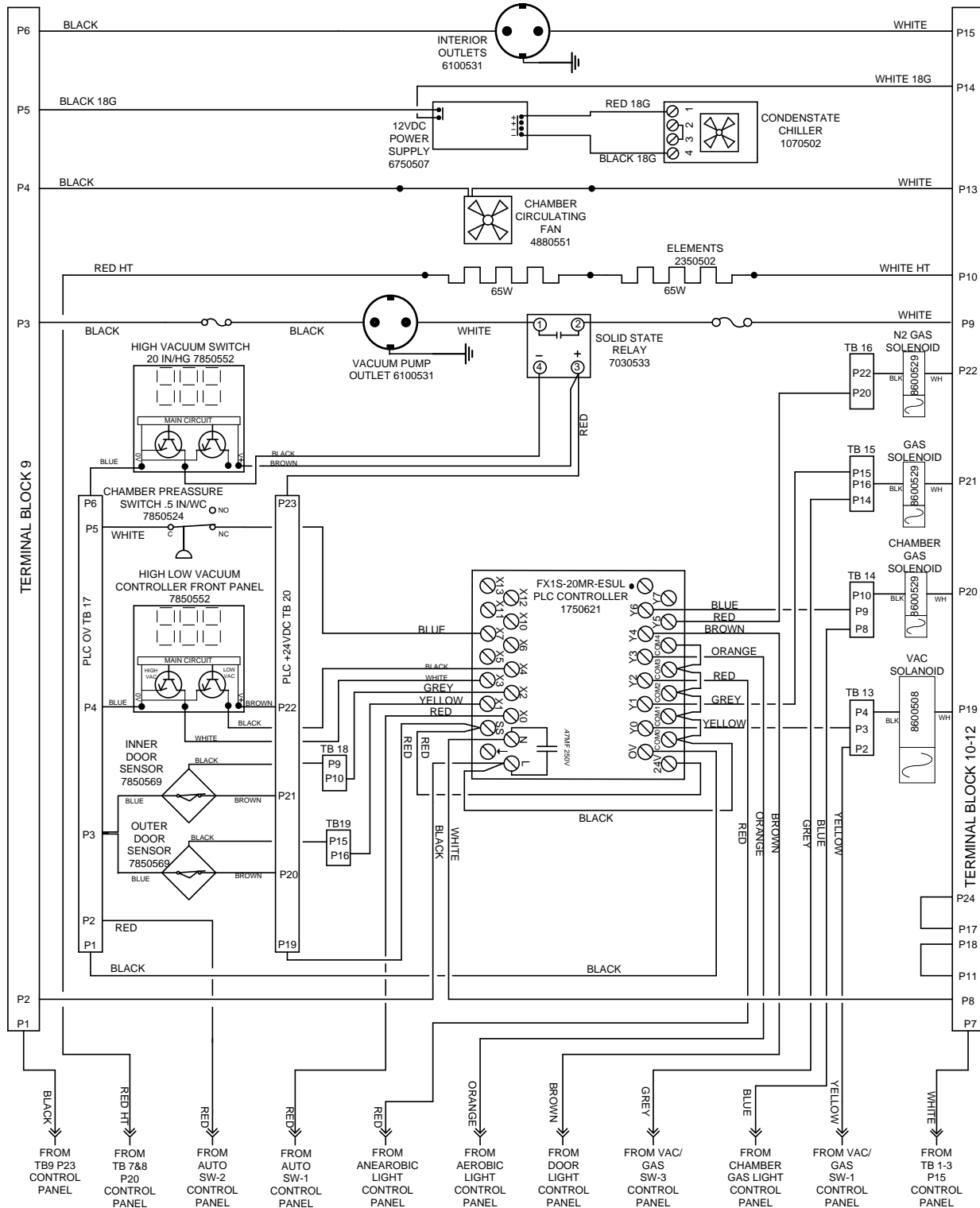

POWER PANEL WIRING BACTRON300-2 (BACTRONIV-2) (9851416)

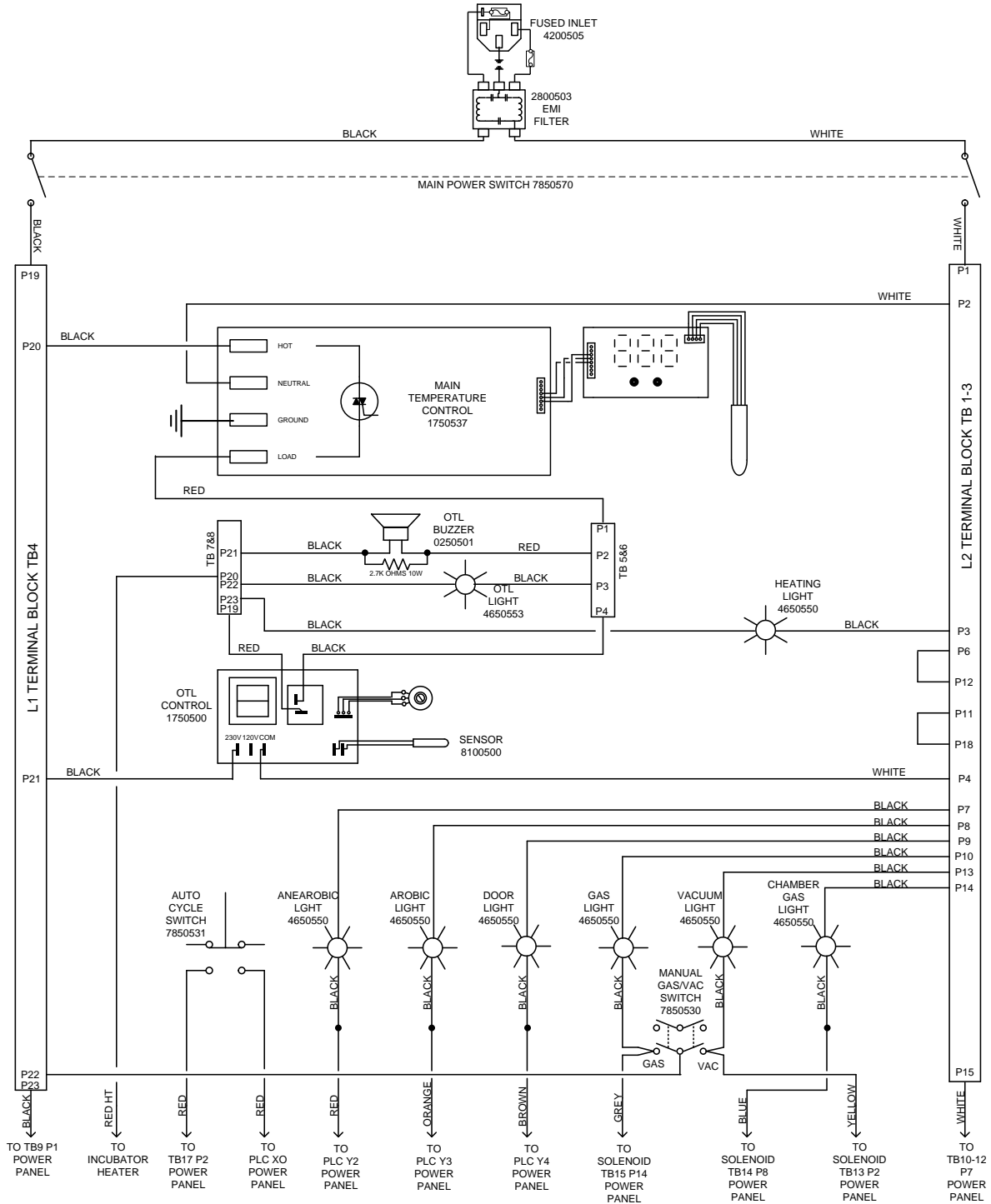

BACTRON ASSESSORY LIGHT BOX

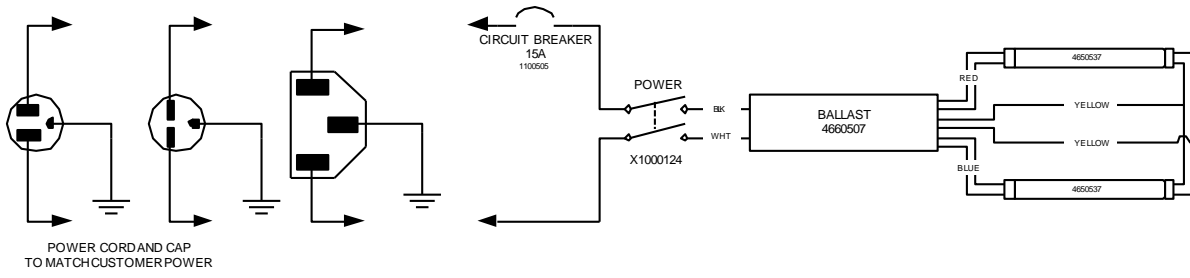

BACTRON LOOP STERILIZER

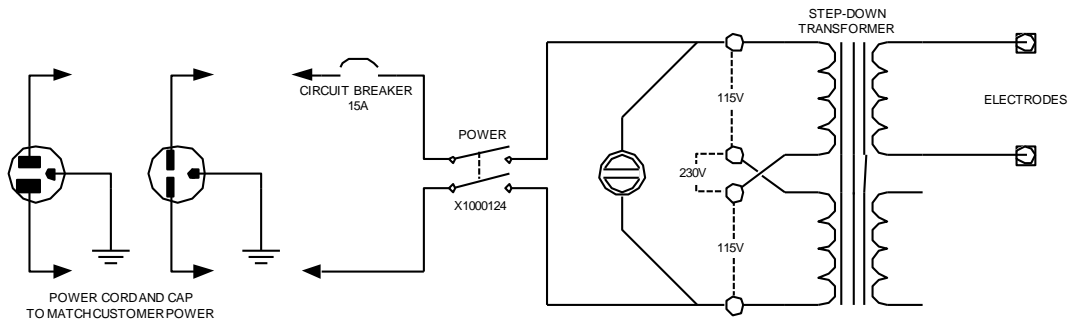

9850715
dlr4/15/09

INTERIOR PLUMBING (9850833)

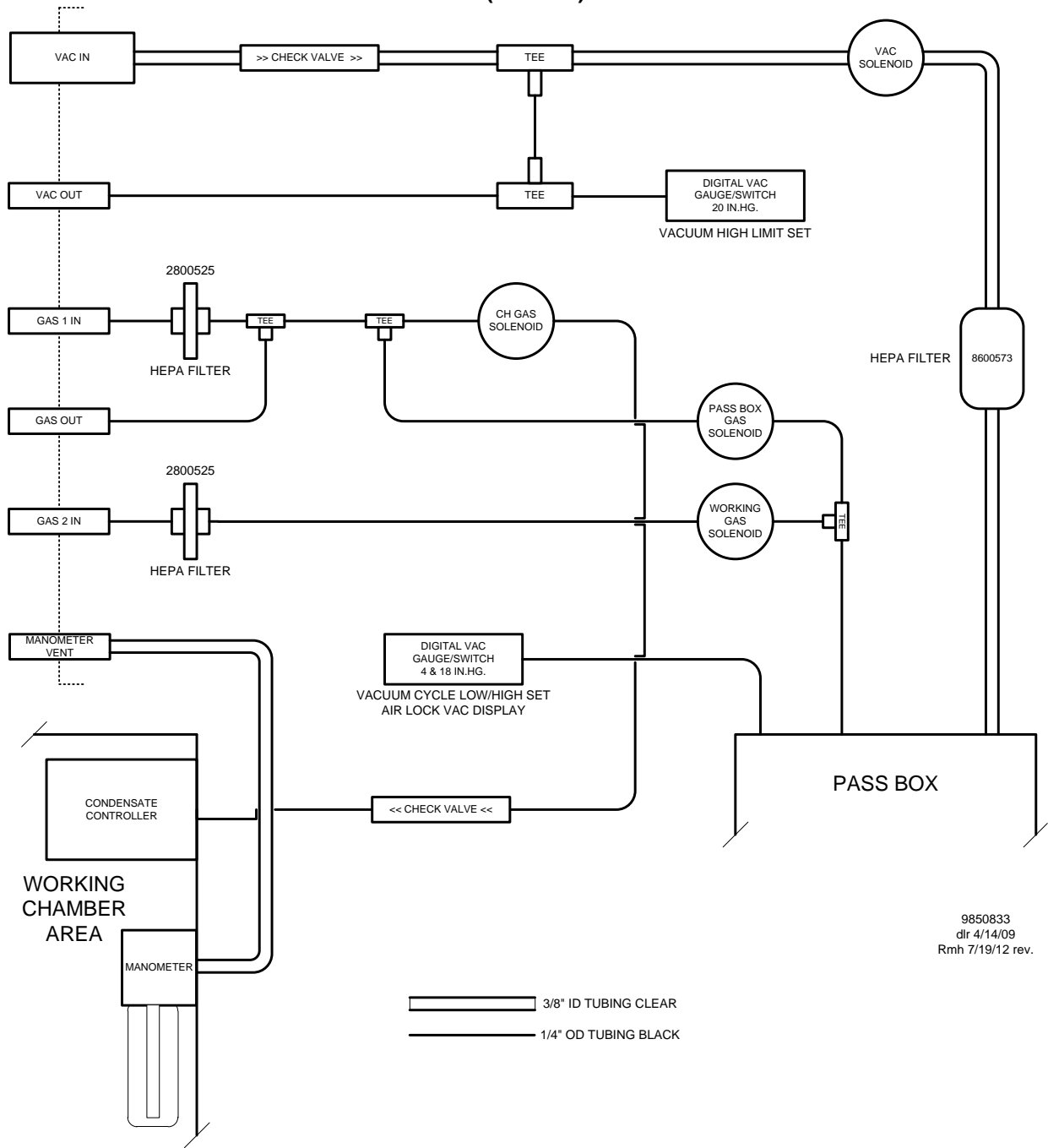

HOSE CONNECTIONS

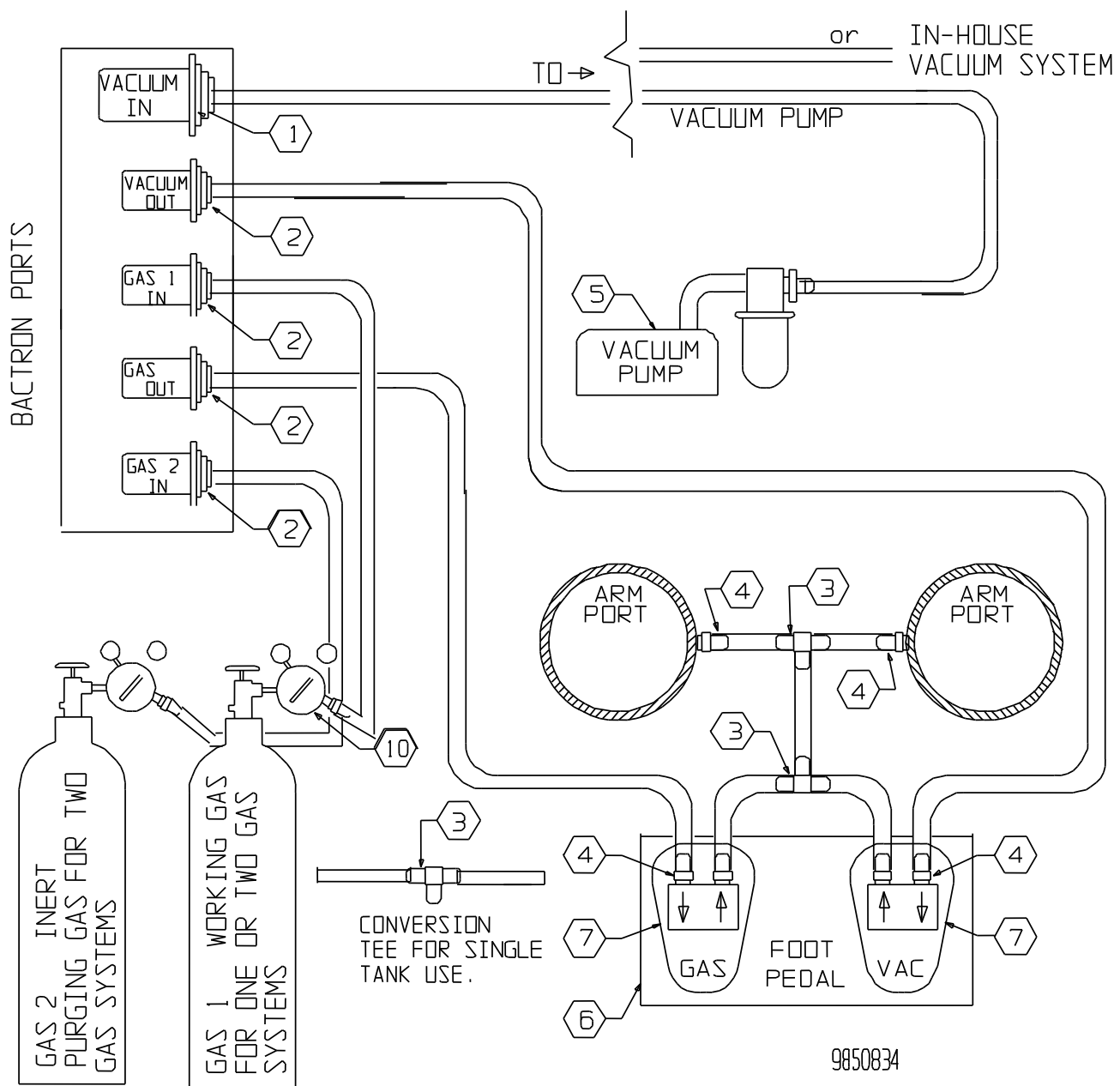

23.0 BACTRON PARTS LIST

DESCRIPTION	PART NUMBER 115 VOLT	PART NUMBER 220 VOLT
ARMPORT DOOR RIGHT	9900698	900698
ARMPORT DOOR LEFT	9900699	9900699
CHECK VALVE FILTER	8600573	8600573
CONTROL - OTP	1750500	1750500
CONTROL - PLC	1750621	1750621
CONTROL – TEMPERATURE		
BACTRON300 BACTRRON300-2 (BACTRONII / BACTRONII-2)	1750623	1750624
CONTROL PROBE - OTL	8100500	8100500
DOOR SENSOR - PROXIMITY SWITCH	7850569	7850539
ELEMENT	2350502	2350502
FUSE OUTLET	3300516	3300537
FUSE INLET	3300520	3300515
GASKET 9 X 9 BURGUNDY (BACTRONEZ BACTRONEZ-2 (BACTRONI /BACTRONI-2)	3450506	3450506
GASKET 12 X 12 BURGUNDY BACTRON300 BACTRON300-2 (BACTRON II/BACTRONII-2) & BACTRON600 BACTRON600-2 (BACTRONIV/BACTRONIV- 2)	3450507	3450507
LIGHT - BACLOOP	4650553	4650553
LIGHT - OTL	4650553	4650553
LIGHT - VACUUM	4650550	4650550
LED LIGHT	9730514	9730514
OTL ALARM	0250501	0250501
OUTLET - VACUUM PUMP	6100538	6100531
POWER CORD	1800540	1800500
POWER CORD - BACLOOP / LIGHTBOX	1800540	1800540
REGULATOR	7150511	7150511
SOLENOID - CHAMBER GAS	8600528	8600529
SOLENOID - GAS 1	8600528	8600529
SOLENOID - GAS 2	8600528	8600529
SOLENOID - VACUUM	8600509	8600508
SWITCH - AUTO START/RESET	7850531	7850531
SWITCH - BACLOOP / LIGHTBOX	7850579	7850579
SWITCH - CHAMBER PRESSURE	9740559	9740559
SWITCH - MAIN POWER	7850570	7850570
SWITCH - MANUAL VAC/GAS	7850530	7850530
VACUUM SWITCH DIGITAL	7850552	7850552
THERMOELECTRIC CONDENSATE CONTROLLER	1070502	1070502
TRANSFORMER - BACLOOP	8350520	8350520