

## **BROOKFIELD MODEL BF35**

Installation, Operation and Maintenance Instructions

Manual No. **M13-10000**



*with offices in:* Boston • Chicago • London • Stuttgart • Guangzhou

**BROOKFIELD ENGINEERING LABORATORIES, INC.**  
11 Commerce Boulevard, Middleboro, MA 02346 USA  
TEL 508-946-6200 or **800-628-8139** (USA excluding MA)  
FAX 508-946-6262 INTERNET <http://www.brookfieldengineering.com>



# TABLE OF CONTENTS

<b>Section 1: Introduction</b> .....	<b>7</b>
Description.....	7
<b>Section 2: Specifications</b> .....	<b>8</b>
<b>Section 3: Safety</b> .....	<b>11</b>
Electrical Requirements.....	12
Environment Conditions.....	12
Installations.....	12
Equipment Operations .....	13
<b>Section 4: Setup</b> .....	<b>14</b>
<b>Section 5: Calibration</b> .....	<b>15</b>
Procedure .....	15
<b>Section 6: Operation</b> .....	<b>17</b>
Measuring Viscosity.....	17
Measuring Gel Strength.....	17
API Testing.....	17
<b>Section 7: Calculations</b> .....	<b>18</b>
<b>Section 8: Disassembly</b> .....	<b>19</b>
<b>Section 9: Maintenance</b> .....	<b>20</b>



The information in this document is believed to be accurate and reliable. However, Brookfield Engineering Laboratories, Incorporated, cannot accept any financial or other responsibilities that may result from the use of this information. No warranties are granted or extended by this document.

Brookfield Engineering Laboratories, Incorporated reserves the right to change any or all information contained herein without prior written notice. Revisions may be issued at the time of such changes and/or deletions.

Any duplication of this manual or any of its parts without expressed written permission from Brookfield Engineering Laboratories, Incorporated is strictly prohibited.

Any correspondence regarding this document should be forwarded to:

Brookfield Engineering Laboratories, Incorporated  
Process Viscometer Division  
11 Commerce Boulevard  
Middleboro, Massachusetts 02346  
U.S.A.  
Telephone: (508) 946-6200  
FAX: (508) 946-6262  
Internet: <http://www.brookfieldengineering.com>

The following Brookfield Engineering Laboratories, Incorporated trademarks and service marks may appear in this document:

All other trademarks or registered trademarks are the property of their respective holders.



# Section 1 - Introduction

## Introduction

The BF35 Viscometer is extensively used worldwide in both the field and laboratory for the precise measurement of rheological properties of fluids.

## Description

The BF35 Viscometer determines the flow characteristics of oils and drilling fluids in terms of shear rate and shear stress over various time and temperature ranges at atmospheric pressure. Speeds are easily changed with a control knob, and shear stress values are displayed on a lighted magnified dial for ease of reading.

The viscometer's motor RPM is continuously monitored and automatically adjusted by the Brookfield Pulse-Power electronic speed regulator to maintain a constant shear rate under varying input power and drilling fluid shear conditions. The eight precisely regulated test speeds (shear rates in RPM) are as follows: 3 (Gel), 6, 30, 60, 100, 200, 300, and 600. A higher stirring speed is also provided. Speeds may be changed with a control knob selection, without stopping the motor.

The BF35 is suitable for both field and laboratory use and uses a motor-driven electronic package to provide drilling fluid engineers with an extremely accurate and versatile tool. The BF35 operates from a 13 - 16 VDC power source. The electronic regulator continuously monitors and automatically adjusts the rotational speed to maintain a constant shear rate under varying fluid shear conditions and input power variations that are commonly found on-site.

# Section 2 - Specifications

## Specifications

<b>Viscometer Specifications</b>	
Instrument Geometry	True Couette Coaxial Cylinder
Speed Accuracy (RPM)	.001
Motor Speeds (RPM)	8 Fixed Speeds (600, 300, 200, 100, 60, 30, 6, and 3)
Readout	Direct Dial
Power Requirements	13 - 16 VDC
Weight (kg)	6.0
Dimensions (cm)	15.2 x 17.8 x 40.6
Shipping Weight (kg)	20.4
Shipping Details (cm)	55.9 x 25.4 x 40.6

### Range of Measurement for BF35

<b>Rotor - Bob</b>	<b>R1B1</b>	<b>R1B2</b>	<b>R1B3</b>	<b>R1B4</b>
Rotor Radius, RR, (cm)	1.8415	1.8415	1.8415	1.8415
Bob Radius, RB, (cm)	1.7245	1.2276	0.8622	0.8622
Bob Height, L, (cm)	3.8	3.8	3.8	1.9
Shear Gap, (cm)	0.117	0.6139	0.9793	0.9793
R Ratio, RB/RR	0.9365	0.666	0.468	0.468

<b>Max. Shear Stress, <math>SS_{MAX}</math><sup>2</sup> (Dyne / cm<sup>2</sup>)</b>	<b>R1B1</b>	<b>R1B2</b>	<b>R1B3</b>	<b>R1B4</b>
F 0.2 (Green)	330	651	1320	2644
F 0.5 (Yellow)	840	1657	3359	6730
F 1.0 (Blue)	1680	3314	6717	13460
F 2.0 (Red)	3360	6629	13435	26921
F 3.0 (Purple)	5040	9943	20152	40381
F 4.0 (White)	6720	13257	26870	53841
F 5.0 (Black)	8400	16571	33587	67302
F 6.0 (Orange)	16800	33143	67175	134603



Shear Rate Range	R1B1	R1B2	R1B3	R1B4
Shear Rate Constant, $K_R$ , ( $\text{sec}^{-1}$ per RPM)	1.7023	0.3770	0.2682	0.2682
Shear Rate ( $\text{sec}^{-1}$ or 1/s)				
3 RPM	5.11	1.13	0.80	0.80
6 RPM	10.21	2.26	1.61	1.61
30 RPM	51.07	11.31	8.05	8.05
60 RPM	102.14	22.62	16.09	16.09
100 RPM	170.23	37.70	26.82	26.82
200 RPM	340.46	75.40	53.64	53.64
300 RPM	510.69	113.10	80.46	80.46
600 RPM	1021.38	226.20	160.92	160.92

Viscosity Ranges <sup>&lt;a&gt;</sup>	R1B1	R1B2	R1B3	R1B4
Minimum Viscosity <sup>&lt;b&gt;</sup> @600 RPM	0.5 <sup>&lt;c&gt;</sup>	4.5	12.7	25
Maximum Viscosity <sup>&lt;d&gt;</sup> @0.01 RPM	10,000,000	89,000,000	255,000,000	500,000,000
<p>&lt;a&gt; Compute for standard Torsion Spring (F 1.0). For other torsion springs, multiply by F factor.</p> <p>&lt;b&gt; Lower viscosities can be measured by the Model 900, however one must take into account the effect of bearing drag, Taylor vortices, zero offset, etc. when looking at the expected accuracy of the reading.</p> <p>&lt;c&gt; For practical purposes, the minimum viscosity is limited to 0.5 cP due to Taylor vortices.</p> <p>&lt;d&gt; Maximum viscosity is based on Maximum Shear Stress and Minimum Shear Rate (RPM). However, due to practical and physical limitations, it may be difficult to take these measurements.</p>				

<b>Viscometer Conversions</b>						
To convert from units on left side to units on top, multiply by factor @ intercept						
	Centipoise (cP)	Poise (P)	g/(cm*s)	(mN*s)m <sup>2</sup>	mPa*s	(lb*s) 100 ft <sup>2</sup>
Centipoise (cP)	1	0.01	0.01	1	1	0.002088
Poise (P)	100	1	1	100	100	0.2088
g/(cm*s)	100	1	1	100	100	0.2088
(mN*s)m <sup>2</sup>	1	0.01	0.01	1	1	0.002088
mPa*s	1	0.01	0.01	1	1	0.002088
(lb*s) 100 ft <sup>2</sup>	478.93	4.789	4.789	478.93	478.93	1

<b>Shear Stress Conversions</b>					
To convert from units on left side to units on top, multiply by factor @ intercept					
	Dyne/cm <sup>2</sup>	Pa	lb/100ft <sup>2</sup>	lb/ft <sup>2</sup>	DR
Dyne/cm <sup>2</sup>	1	0.1	0.2084	0.002084	0.1957
Pa	10	1	2.084	0.02084	1.957
lb/100ft <sup>2</sup>	4.788	0.4788	1	0.01	0.939
lb/ft <sup>2</sup>	478.8	47.88	100	1	93.9
DR	5.107	0.5107	1.065	0.01065	1

### What Bob and Spring Should I Use?

There is often confusion or misunderstanding about what a viscometer can actually measure. For example, a viscometer with an R1B1 F1 combination can measure water fairly well at 100 RPM and higher, but at 3 RPM, the readings would be shaky at best. While on the other hand, a linear fluid with a viscosity of 15000, could not get past 6 RPM with the same combination.







To estimate which spring might be best, use the formula below to calculate a Minimum Spring factor, where one establishes the maximum RPM the fluid is going to be tested at, as well as what the expected “Apparent Viscosity” of the fluid at that RPM. If the Factor comes out as .87, then an F 1.0 spring should be used. If it comes out as .16, then an F 0.2 spring would be best. To cover all ranges, it may be necessary to use more than one spring.

$$\text{Minimum Spring Factor (F)} = \frac{\text{RPM(max)} * \text{AV(max)}}{\text{BOB(F)} * 90000}$$

<b>Bob (F)</b>	
<b>R1B1</b>	<b>1</b>
<b>R1B2</b>	<b>8.9</b>
<b>R1B3</b>	<b>25.4</b>
<b>R1B4</b>	<b>50.7</b>

# Section 3 - Safety

## Safety

Explanation of Symbols	
	<p><b>Caution: Risk of Danger</b> - This symbol directs the operator to consult the instruction manual for safety related warnings. (ISO-7000-0434)  <b>Whenever this symbol is used on the equipment, the user must consult the manual to determine the nature of the hazard and any actions which have to be taken.</b></p>
	<p><b>Fuse:</b> This is the internationally recognized symbol for a user-replaceable fuse. This symbol will be followed by information required to guide the user to choose the proper replacement fuse.</p>
	<p><b>Direct Current (DC):</b> This symbol indicates an input (or output) that is direct current only. (IEC 60417-5013)</p>
 <b>Note</b>	<p><b>Note:</b> This symbol will indicate important notes and helpful hints for the operation of the equipment.</p>
	<p><b>Polarity:</b> This symbol indicates that the equipment receives positive voltage on the center pin of the connector and the return voltage is on the outer case.</p>
 <b>Tip</b>	<p><b>Tip:</b> This symbol is used to identify operational information and best practices to obtain the most reliable data.</p>
	<p><b>Caution: Note</b> - This symbol is used to indicate statements in the manual which warn against actions which may cause damage to the equipment during routine service or maintenance.</p>

## Electrical Requirements



The BF35 Viscometer is to be powered by a DC power source capable of providing between 13 and 16 volts DC. The equipment is current limited to 4 amps by a user-replaceable fuse. However, we suggest that the power supply be current limited to less than 4 amps to provide additional protection to the equipment.

**Power (On/Off) Switch**



**Input Connector:  
13 - 16 VDC Power  
Inlet / Emergency  
Disconnect Device**



When connecting the equipment to your power source, make sure that the 13 - 16 VDC is connected to the center pin of the connector.



The equipment is supplied with a user-replaceable fuse. This fuse must only be replaced by a 250-volt, 4-amp, time-delayed fuse.

## Environment Conditions

The equipment is designed for use in normal environmental conditions:

- Indoors
- At or below an altitude of 2,000 m (6,562 ft)
- In temperatures between 5° and 40°C (41° - 104°F)
- With a maximum relative humidity of 80% for temperatures up to 31°C (88°F) decreasing linearly to 50% relative humidity at 40°C (104°F)
- This equipment has not been rated according to IEC 60529

## Installations



**Note**

The BF35 Viscometer should be used in a location where it will not be subjected to excessive moisture. It should be placed on a flat, stable surface in a well-ventilated environment.



**Caution - Risk of Danger:** This equipment produces sound pressure in excess of 85 dBA. Protective measures (such as hearing protection, noise-reducing baffles, or a hood) should be considered.

## Equipment Operation



**Caution - Risk of Danger:** The (13 - 16 VDC) power cord and the DC inlet are the emergency disconnect devices. Do not position the equipment such that it is difficult to operate the emergency disconnect devices.



**Caution - Risk of Danger:** In normal operation, this equipment may liberate the potentially poisonous gasses listed below. However, the list below is dependent upon the chemical makeup of the sample fluids presented for testing. Care should be taken to ensure that: no unexpected or anomalous chemicals are contained or added to the test samples; the test environment is adequately ventilated; and, when necessary, appropriate personal protective equipment is employed.

- Hydrogen Sulfide (H<sub>2</sub>S)
- Methane (CH<sub>4</sub>)
- Carbon Dioxide (CO<sub>2</sub>)
- Sulfur Dioxide (SO<sub>2</sub>)



**Caution - Risk of Danger:** The samples presented for testing may contain flammable substances. The following risk-reduction procedures must be followed to ensure the safe operation of the equipment.

- Always use in a well-ventilated area.
- Keep away from open flames.



**Caution - Risk of Danger:** If this equipment is operated in a manner not specified by the manufacturer (Brookfield), the protections provided by the equipment may be impaired.



**Caution - Risk of Danger:** This equipment may operate unexpectedly if the equipment is energized when the Speed Selector Knob and Power (On/Off) Switch are left in the “On” position. Care should be taken to ensure both switches are in the “Off” position prior to energizing the equipment. Also, care should be taken to ensure that the Speed Selector Knob is in the “Off” position prior to turning the Power (On/Off) Switch to the “On” position.



Speed Selector Knob

# Section 4 - Setup

## Setup

1. Connect the instrument to a 13 - 16 VDC, current-limited power source.
2. With the instrument turned off, place the splash guard onto the bob shaft with the short tube end pointed up towards the bearings. Push up.
3. Screw on the appropriate bob with the tapered end up towards the splash guard.
4. Place the sleeve onto the rotor over the bob. The threads assure the rotor will attach evenly and uniformly each and every time.
5. The power switch is located on the back panel. Turn the unit on.
6. Place a properly prepared sample of test fluid in a sample cup and immerse the rotor sleeve exactly to the fill line on the sleeve by raising the platform. Tighten the lock nut on the platform.

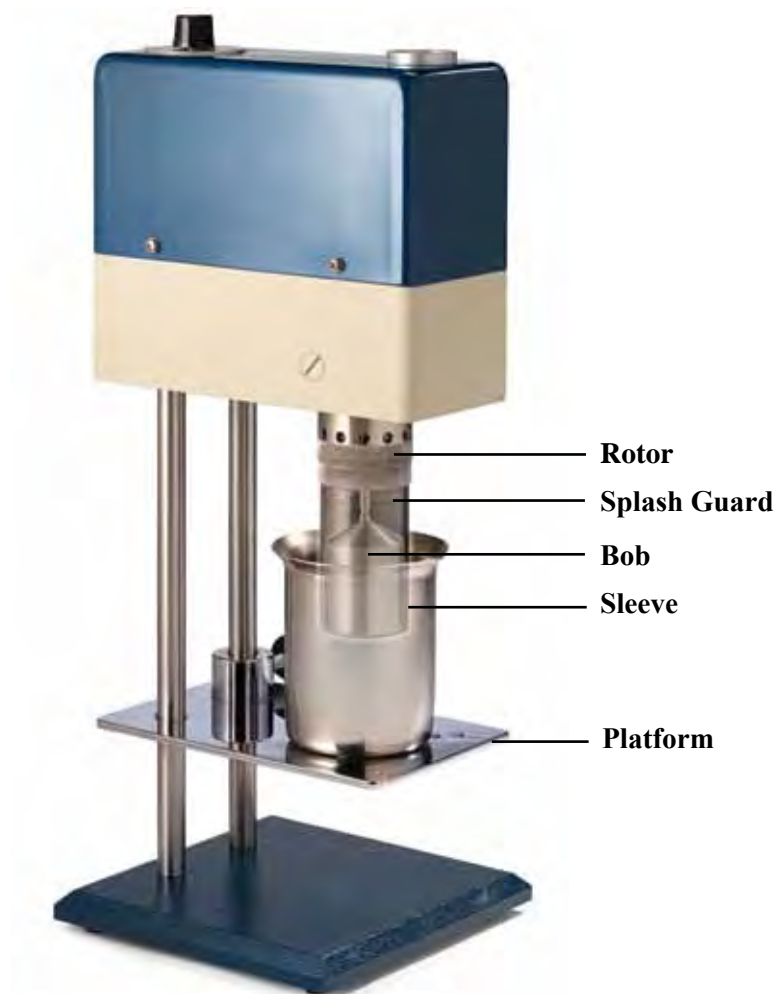

# Section 5 - Calibration

## Calibration

The BF35 Viscometer can lose calibration while in service if the bob shaft bearings become contaminated or if the bob shaft itself is bent. If the dial does not read zero when it should or if there is excessive dial deflection when the main shaft is turning, this may indicate that the bob shaft bearings are sticking. If the spring appears to be non-linear, the bob shaft may be bent. Your viscometer will require servicing if it exhibits any of these symptoms.

According to API Recommended Practice 10B-2, viscometers being used for testing well cement should be calibrated quarterly. API Recommended Practice 13B-1 and 13B-2 specify viscometers being used for drilling fluids should be checked monthly.

## Procedure

1. Choose the certified calibration fluid using the temperature-viscosity chart supplied with the calibration fluid to cover the viscosity range of interest. Make sure the lot number on the chart matches the lot number on the fluid container. Each lot of standard fluid is individually certified. The viscosity will normally vary slightly from lot to lot.
2. Clean and dry the viscometer bob, sleeve, and cup. Place the viscometer and the calibration fluid side-by-side on the counter top in a room with a reasonably constant temperature (variation of less than  $5^{\circ}\text{F} \pm 2.5^{\circ}\text{F}$ ). Allow the viscometer and the fluid to stand at least two hours to equilibrate.
3. Operate the viscometer in air for two to four minutes to loosen up the bearings and gears. Observe the rotor sleeve for excessive wobbling and replace if necessary.
4. Fill the cup to the scribed line with calibration fluid and place it on the viscometer stage. Move the stage upward until the fluid level is to the fill line on the sleeve.



**Viscometer Sleeve**

5. Place a thermometer capable of  $\pm 0.2^{\circ}\text{F}$  ( $0.1^{\circ}\text{C}$ ) into the fluid and hold or tape it in place to prevent breakage. Operate the viscometer at a low speed

setting until the thermometer reading becomes stable to within  $\pm 0.2^{\circ}\text{F}$  ( $0.1^{\circ}\text{C}$ ) per seconds. Note and record the temperature reading.

6. Once the temperature has stabilized, operate the viscometer at 600 RPM and then at 300 RPM. Note and record the dial readings to the nearest 0.5 dial unit.
7. Using the temperature-viscosity chart supplied with the calibration fluid, determine the certified viscosity to the nearest 0.5 centipoise.
  - a. Compare at 300 RPM reading to standard viscosity and record the deviation plus or minus.
  - b. Divide the 600 RPM dial reading by 1.98, compare that to standard viscosity, and record the deviation plus or minus.
8. Deviations exceeding 1.5 dial units are not acceptable. If the deviation exceeds this tolerance, the viscometer will require adjustments or calibration by a qualified technician.
9. Record the viscometer serial number, date, and deviation. Mark on the viscometer the date of calibration and a general indication of the calibration check status.



# Section 6 - Operation

## Operation

### Measuring Viscosity:

1. Mix the sample on the “STIR” setting for 10 seconds while heating or cooling the fluid. Monitor the temperature with a thermometer. Continue to mix until the sample reaches the target temperature.
2. Rotate the knob to one of the speed settings. When the dial reading stabilizes, record the reading and the temperature. Repeat this step for any other speeds that your test requires.



Tip

Always start with the higher RPM and work your way down to the lowest RPM. For example, if you need readings at 100 RPM, 200 RPM, and 300 RPM, record the measurement at 300 RPM first, then 200 RPM, then 100 RPM, then gel strengths (if necessary).

### Measuring Gel Strength:

1. Mix the sample on the “STIR” setting for 10 minutes.
2. Rotate the knob to “GEL” and immediately shut off the power.
3. As soon as the sleeve stops rotating, wait 10 seconds and turn the power back on while looking at the dial. Record the maximum dial deflection before the gel breaks. This is the 10 second gel strength.



Note

When measuring gel properties, the dial does not have to return to zero during the quiescent period. Therefore, it should not be forced back to the zero setting if it does not freely do so. When determining the maximum dial deflection, no allowance needs to be made if the dial did not start at zero. Only the maximum dial deflection is of interest. Rheological properties and characteristics of the sample will determine if the dial returns to zero during the quiescent periods of the gel measurements.

4. For the 10 minute gel strength, re-stir the fluid and wait 10 minutes before recording the maximum dial deflection.

### API Testing:

1. Mix the sample on the “STIR” setting for 10 seconds.
2. Set the speed to 600 RPM. Wait for the reading to stabilize and then record the dial reading and temperature.
3. Set the speed at 300 RPM. Wait for the reading to stabilize and then record the dial reading and temperature.
4. Stir the sample again for 10 seconds.
5. Set the speed to “GEL” and immediately shut off the power.
6. As soon as the sleeve stops rotating, wait 10 seconds and turn the power on while looking at the dial. Record the maximum dial deflection before the gel breaks. This is the 10 second gel strength.
7. For the 10 minutes gel strength, re-stir the fluid and wait 10 minutes before recording the maximum dial deflection.

# Section 7 - Calculations

## Calculations

Plastic Viscosity (PV), cP	= 600 RPM reading - 300 RPM reading
Yield Point (YP), lb./100 ft <sup>2</sup>	= 300 RPM reading - Plastic Viscosity (PV)
Apparent Viscosity (AV), cP	= 600 RPM reading / 2
Gel Strength, 10 second, lb./100 ft <sup>2</sup>	= the maximum dial deflection after 10 sec.
Gel Strength, 10 minute, lb./100 ft <sup>2</sup>	= the maximum dial deflection after 10 min.

# Section 8 - Disassembly

## Disassembly

Clean the viscometer after every test.

1. Remove the sleeve from the rotor.
2. Remove the bob.
3. Once the bob is removed, remove the splash guard and wipe down the bob shaft. Clean all removed parts with soap and water and dry them thoroughly.



**Keep the instrument upright at all times, especially when cleaning so that water does not get into the bearings.**

# Section 9 - Maintenance

## Maintenance

From time to time, the bearings will need to be changed. Complete the following to determine if it is time to perform this maintenance procedure:

1. The viscometer should have a zero dial reading when placed in an upright position with the sleeve not immersed in fluid prior to running tests.
2. With the instrument in this position, rotate the sleeve at 600 RPM. The dial reading in air should not exceed one.
3. Place water in a suitable container and immerse the rotor sleeve to the fill line.
4. Rotate the sleeve at 600 RPM. The dial reading in water should be between 1.5 and 3.0.
5. At 300 RPM, the dial reading in water should be between 0.5 and 2.0.

If the viscometer fails to pass any one of the above tests, the bearings are bad and should be replaced by a qualified instrument technician.

## Bob Shaft Bearing and Torsion Spring Replacement:

### *Tools Required:*

Allen Wrench, 1/16"  
Torsion Spring Removal Tool  
Retainer Ring Pliers (small)  
External Retainer Ring Pliers

1. Unplug the power supply and remove the sleeve and bob.
2. With the appropriate allen wrench, loosen the set screw in the speed control knob. Remove the speed control knob from the unit.
3. Remove all four flat head screws on the outer housing cover and gently lift the cover upward.
4. Use an allen wrench to loosen the set screw (one turn counter-clockwise) from the aluminum bushing located inside the torsion spring. The set screw is located at the top of the aluminum clamp sleeve used for the torsion spring.
5. Loosen the two screws and remove the stop block.
6. Loosen the top set screw (one turn counter-clockwise) on the dial.
7. Gently lift up on the torsion spring to remove it from the aluminum clamp sleeve and dial.



**Do not stretch the torsion spring.**

If you are replacing only the torsion spring, discard the old spring, and skip to step 20 to complete the process.

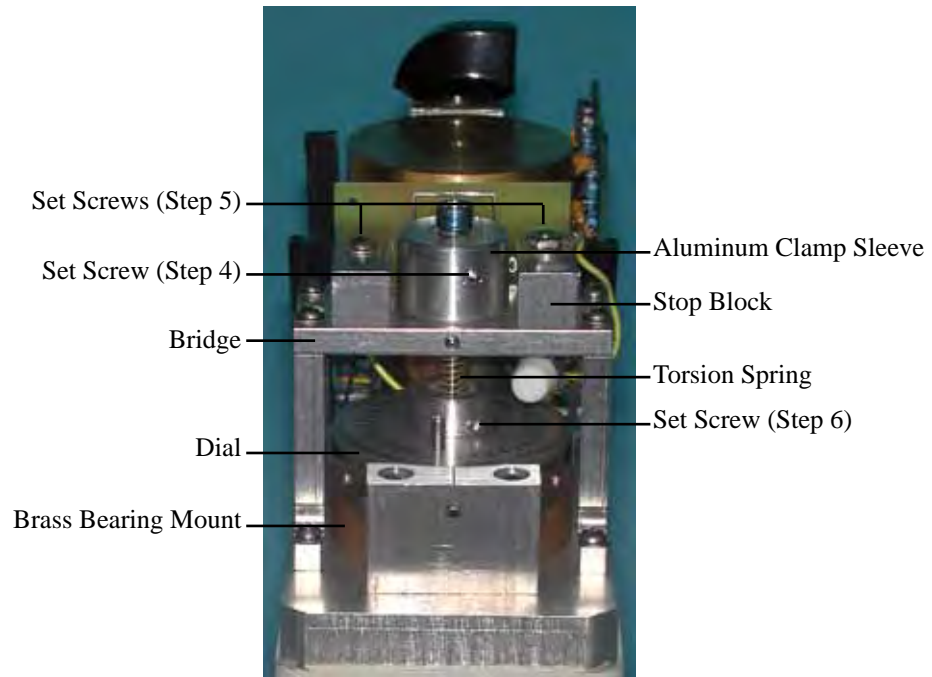

8. Remove the four screws from the bridge and lay it gently to the right side.



**Do not touch the encoder that encircles the flywheel.**

9. Loosen the set screw (one turn counter-clockwise) on the bottom of the dial and pull down on the bob shaft to remove them both.
10. Remove the two screws on the brass bearing mount (upper bearing). Hold the upper brass bearing mount by the hand for easier access to the retainer ring and bearing.



**Be careful not to damage the pins.**

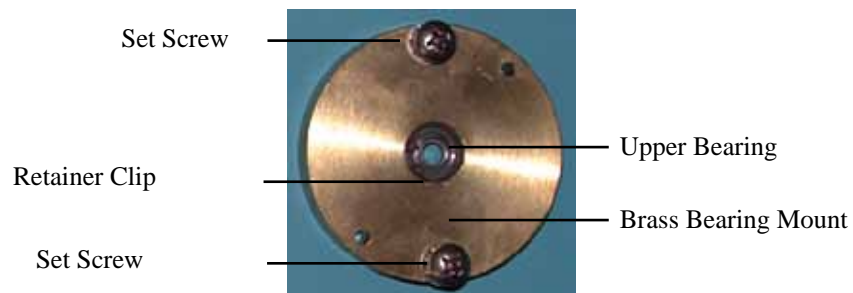

11. The upper bearing is located inside the brass bearing mount. Use the retainer ring pliers to remove the retainer ring. Push the bearing upwards to remove the upper bearing from the brass bearing mount.
12. Use surgical gloves to insert a new upper bearing into the brass bearing mount and replace the retainer ring with the retaining ring pliers.



**Do not touch the bearing with bare hands. Dirt, oils, and other contaminants can damage the bearing.**

13. Replace the brass bearing mount back onto the two pins and tighten the two screws.
14. Remove the Splash Guard, loosen the set screw on the lower brass bearing shield (one turn counter-clockwise), and slide the lower bearing down the bob shaft to remove all three components.
15. Use surgical gloves to apply a new lower bearing onto the bob shaft.
16. Install the lower brass bearing shield and tighten the set screw. Slide the splash guard back up the bob until it touches the lower brass bearing shield.



**Note**

**The bearing should be able to free spin for up to two minutes. If it does not, replace it with a new bearing.**

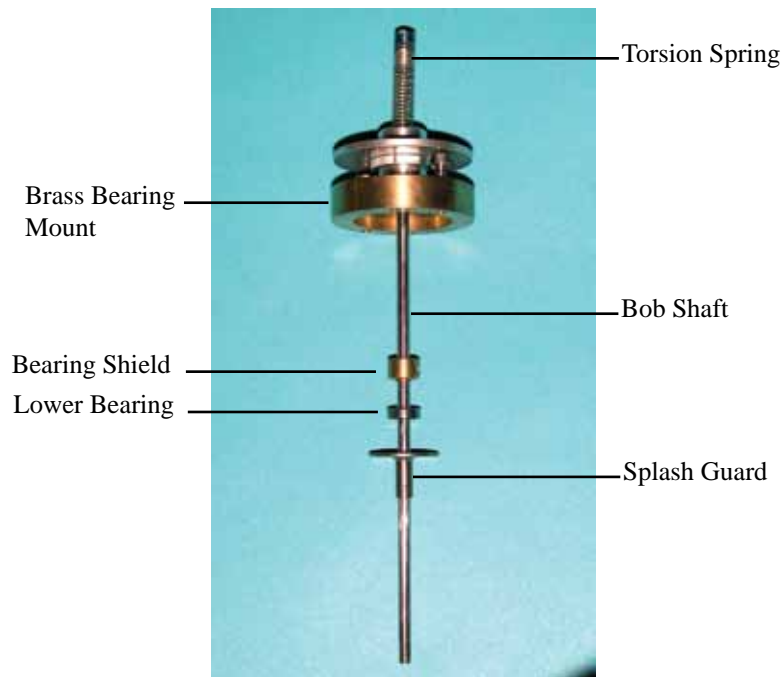

17. Slide the bob shaft up through the upper brass bearing mount. Turn the bob shaft in the direction that allows the “Flat” located at the top of the bob shaft to be positioned towards you.
18. Align the bottom set screw on the dial with the “Flat” on the bob shaft and tighten firmly. Make sure the set screws are perpendicular to the tip of the bob shaft.



**Note**

**The bob shaft should rotate smoothly without any noise.**

19. Replace the bridge being careful not to touch, or bend the encoder. Tighten the four screws.

20. Gently slide the torsion spring through the aluminum clamp sleeve and into the dial. Make sure the bottom of the torsion spring is seated properly inside the dial. Tighten the set screw located at the top of the dial to secure the torsion spring.
21. Replace the stop block and the two screws. Make sure that the zero dial reading is aligned with the fill on the stop block.
22. Press down on the torsion spring until it is flush with the Aluminum Clamp Sleeve and tighten the set screw.
23. Replace the bob and sleeve.
24. Re-attach the main housing cover and re-calibrate.