

SECTION SIX

WAVELENGTH SCAN

Wavelength scans can be collected in either absorbance or transmittance. The spectra are available for formatting changes which include expansion and contraction of either axis, zoom, overlaying of up to twelve spectra, overlaying of multiple functions of the same spectrum, and "Trace" to find the abscissa and ordinate values at any user-selected position.

Calculations can be made on wavelength scan data to find the peaks, valleys and/or specified points, to calculate first to fourth derivative, and to calculate the log of absorbance. Scatter correction can be performed on any spectrum. Spectral addition, subtraction, and multiplication can also be performed on stored spectra. Net absorbance calculations can be made on any stored spectrum using either one or two baseline points.

6.1 Principles of Operation

Blank - Background Data

The background data are collected when the instrument is blanked. A cuvette filled with the solvent used to prepare the samples should be in the sample compartment when the blank is read.

The blank data are stored in the instrument and can be reused for an unlimited number of sample spectra. A new blank should be read every time a solvent is changed. For optimum performance, a new blank should also be read if the instrument has not been used for over an hour.

For very high precision data, the same cuvette should be used for the blank and sample spectra, as even matched cuvettes have a slight mismatch which can be seen by the DU Series 600 Spectrophotometer. The blank should be rerun for every sample.

Sample Data

After the sample data are collected, the blank is subtracted and the difference in absorbance (or ratio in transmittance) is plotted on the display and stored in the instrument memory. The data points are connected.

Repetitive Scanning

Repetitive scans can be made by inputting more than one for the "scans per sample" and setting the "interval time" to the desired value. The interval time is the time between the start of successive scans. The minimum interval time is 0.1 seconds.

Derivative

First to fourth derivative can be calculated and displayed on any absorbance spectra using the Savitzky and Golay¹ coefficients. Two data points before and two data points after the point of interest are used to calculate the derivative. (For the fourth derivative, only, three points before and after the point of interest are used.) This calculation is done for every data point in the spectrum to determine the derivative spectrum.

¹Savitzky, A., and Golay, M., *Anal Chem* 36, p1627f (1964).

Log of Absorbance

The log base 10 is calculated and displayed for absorbance spectra. Because the log of 0 is negative infinity, if some data points in the spectrum are zero or are very close to zero, the log spectrum may not be usable in these regions.

Peak/Valley Pick

The most intense peaks and/or valleys are found and displayed with the spectral data when the peak pick calculation is selected. These are found by calculating the first derivative as described above. When the sign of the derivative changes from positive to negative, a peak is detected. A valley is detected when the sign of the derivative changes from negative to positive. Up to 30 peaks (valleys) can be input. If the instrument finds more than the input number of peaks (valleys), the most intense ones will be tabulated. Each time that the wavelength limits or the smoothing function is changed, the instrument performs the peak pick calculations again.

Point Pick

Point pick is a tabulation of data at up to 12 user-selected wavelengths.

Trace

The actual stored data points are accessed using "Trace".

Smoothing

The displayed wavelength scan can be smoothed using a selectable smoothing function. The calculation, using the Savitzky and Golay¹ method (as modified for end points by Peter A. Gorry²), is done for every data point in the scan, using the data points before and after the point of interest. The user selects the total number of data points used for the calculation, from 7 to 25. Use of too few points may not reduce the spectral noise to the desired level, while use of too many points can cause real peaks to be flattened and/or combined.

²Gorry, Peter A., Anal Chem, **62**, 1990, p570f.

Addition/Subtraction/Multiplication - (+-* Scans)

Stored spectra can be added, subtracted or multiplied, using the equation:

$$\text{Scan} = (\text{scan A} \times \text{F1}) +/-* (\text{scan B} \times \text{F2}) +/-* \text{F3},$$

where scan A and scan B are stored spectra, F1 and F2 are factors which are multiplied by each data point in scan A and scan B, respectively. F3 is an additional value that is added/subtracted/multiplied to each point in the spectrum.

Scatter Correction (Spectral)

Turbid samples, rough samples or particles in a sample cause light from the source to be scattered, so that it does not reach the detector. In the spectrum of a sample with scattering particles, the scattered light appears as increased absorbance with decreasing wavelength. If two points in the spectrum can be identified, where the observed absorbance is entirely a result of scatter, a spectrum of the scatter can be estimated and subtracted from the sample spectrum to produce a sample spectrum in the absence of scatter.

The equation used to estimate the scatter is:

$$A_s = a \lambda^b,$$

where,

A_s is the absorbance due to scatter at a particular wavelength, and a and b are constants.

For the scatter correction to be accurate, it is necessary to correctly specify two wavelengths where the observed absorbance is entirely a result of scatter. These points should be at least 50 to 100 nm apart for the most accurate correction.

The spectrum due to scatter and the corrected sample spectrum are displayed, along with the constants "a" and "b".

Net Absorbance Calculations

It is possible to correct a sample absorbance peak for a raised or sloping baseline, which may be caused by turbidity in the sample, using net absorbance calculations. Net absorbance calculations can also correct for small differences in cuvettes caused by slight uncleanness, as shown in Beckman publication T-1548.

The user can choose either one or two baseline points for the calculation. If one baseline point is chosen, the absorbance at the base wavelength is subtracted from the absorbance at the peak wavelength to provide the net absorbance. The base wavelength can be either to the right or left of the peak wavelength.

If two baseline points are chosen, a straight line is drawn between the absorbance values at two base wavelengths. The absorbance of that line at the peak wavelength is subtracted from the absorbance of the sample at the peak wavelength to provide the net absorbance. The base wavelengths can be on either side of the peak wavelength, or can both be on the same side.

Scan Files

Spectral data are stored in a Scan file. Each Scan file contains the spectral data from one sample. The Scan file is named using up to five characters, allowing the instrument to append the file name with three characters. These characters are numbers, starting with 001. For example, if the Scan file is named "SCANS", the data from the first sample will be stored in file "SCANS001". The data from the second sample will be stored in file "SCANS002". Data from up to 999 samples can be stored with the same file name.

If "Autosave" is enabled, the data for every sample is stored automatically, using the input Scan file name. If "Autosave" is not enabled, the data for each sample is stored in a temporary file named "WORK_00X". When both "Autosave" and "Autoprint" are disabled, scans from up to twelve samples are stored in this temporary manner; then the scans must be cleared or saved before additional scans can be collected.

6.2 Parameter Setup

Click on "WAVELENGTH SCAN" from the Main window to start the analysis. The Wavelength Scan window, Figure 6-1, is displayed. The Wavelength Scan window is used to select analysis parameters, collect spectral data and display spectral data. Multiple functions of the sample (i.e. absorbance and first derivative) are displayed in this window. Peak pick, valley pick, and point pick values are also displayed.

NOTICE

Use the RediScan mode to collect and display spectral data with minimum parameter setup.

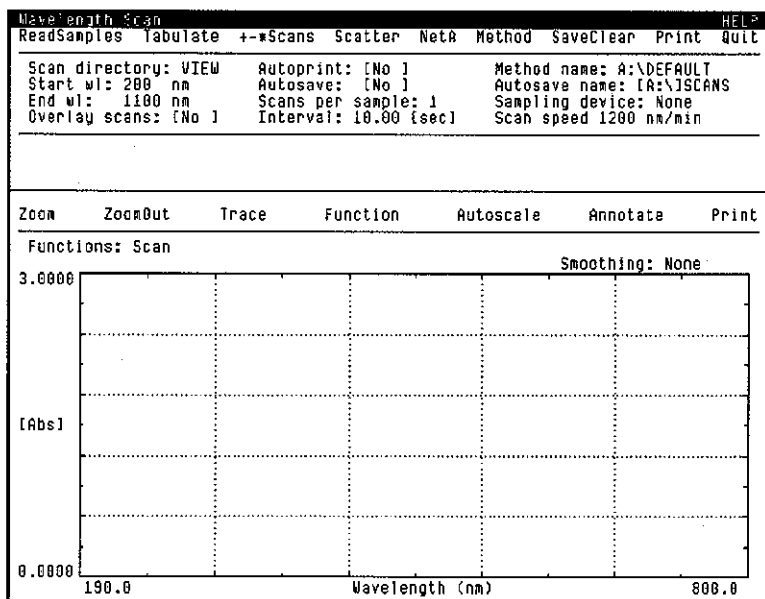

Figure 6-1. Wavelength Scan Window

Use the Method window to setup the analysis parameters:

1. Click on <Method> to display the Method window, Figure 6-2. The Method window is used to setup analysis parameters, recall stored methods and create new methods. General information on method windows is provided in section 3.8.
2. To recall a stored method, click on the desired method name in the listing at the top of the Method window.

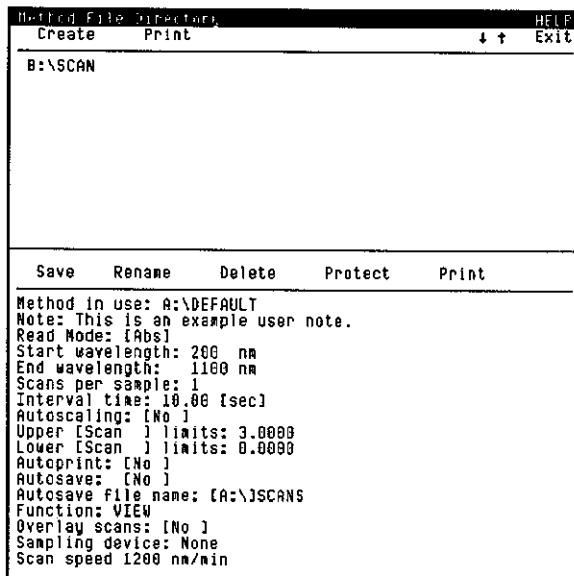

Figure 6-2. Method Window

- The analysis parameters are displayed on the lower part of the Method window. Input the desired analysis parameters:

Method in use - This displays the name of the method that has been selected. If the method is protected, ****PROTECTED**** is displayed following the method name. If the method is protected, the analysis parameters cannot be changed. To input a new method name, click on **<Create>**.

Note - Click on to input a 40-character message.

Read mode - Toggle between **[Abs]** and **[%T]** to select readings in absorbance or transmittance, respectively.

Start / End wavelength - Click on to input the starting (lower), then the ending (higher) wavelength.

Scans per sample - For repetitive scanning, input the total number of times each sample is to be scanned. If the Auto Cell Holder or Batch Sampler is selected for the "Sampling device", the input for this parameter is set to 1.

Interval time - For repetitive scanning, input the time between the start of successive scans, in either seconds or minutes. The

minimum interval time is dependant upon the wavelength range and whether "Autosave" and/or "Autoprint" are enabled.

Autoscaling - Autoscaling adjusts the ordinate axis to display the highest peak full-scale. Toggle between [Yes] and [No] to enable or disable autoscaling.

Upper / Lower limit - Input the upper and lower limits for the ordinate axis display of the spectral data. If autoscale is enabled, the displayed values are ignored.

Autoprint - Toggle between [Yes] and [No]. If enabled, each spectrum is printed automatically on the Dot Matrix Printer after data collection is complete.

Autosave - Toggle between [Yes] and [No]. If it is enabled, each scan is stored automatically as it is collected using the input "Autosave file name".

Autosave file name - If autosave is enabled, input a five-character prefix for the file name.

Function - The Function window is used to select derivative or log spectral display and to select peak, valley and/or point pick tabulation. Click on "VIEW" to display the Function window. Refer to section 6.6 for more information. (On the Wavelength Scan window, click on <Function> in the menu bar to display the Function window.)

Overlay scans - Toggle between [Yes] and [No]. If it is enabled, multiple scan files can be overlaid. If it is disabled, only one scan file can be displayed.

Sampling device - Display the Sampling Device window to select the sampling device.

Scan speed - Select from [2400], [1200], [600], [240] and [120] to set the scan speed in nanometers per minute.

3. To store the analysis parameters in the selected method file, click on <Save>.
4. Click on <Exit> to display the Wavelength Scan window with the parameters from the selected method.

To input the desired parameters on the Wavelength Scan window:

1. The analysis parameters are listed near the top of the window. To change any of these, click on the parameter and input the desired value. A description of the parameters is provided above.
2. The ordinate limits are input by clicking on the displayed values on the graph and inputting the desired values.
3. Calculations (derivative, peak pick, point pick, etc.) performed on the data are selected by clicking on **<Function>** to display the Function window. Refer to section 6.6 for more information.

6.3 Analysis of Single Samples

After the desired parameters are displayed on the Wavelength Scan window, samples can be run.

1. Place a cuvette of solvent in the cell holder. Click on <<**BLANK**>>. The instrument blanks on the solvent.

Sipper - Aspirate and read the substrate by pressing {**FILL/BLANK**}.

NOTICE

If the solvent (blank solution) has significant absorbance in the wavelength region of interest, the dynamic range of the instrument can be increased by adjusting the scan gain for the blank. Instructions are provided in section 2.5.

2. Place a cuvette of sample in the cell holder and click on <**Read-Samples**>. (As an alternative, click on the right mouse button with the cursor in any position.)

Sipper - Aspirate and read each sample by pressing {**FILL/READ**}. Flush or return each sample before reading the next.

3. The sample is scanned and the data is displayed. The data may be stored or printed automatically, based upon the selections for "Autosave" and "Autoprint". A typical Wavelength Scan window with data from a single sample is shown in Figure 6-3.
4. If "Autoprint" is disabled, click on <**Print**> to print the sample data. The data are plotted on the Dot Matrix Printer unless the X-Y Plotter is installed and selected for "Send graph to" in the Printer and Plotter Configuration window.
5. The data can be manipulated using the instructions provided in section 6.5. <**Function**> can be used to display additional functions (derivative, peak pick, point pick, etc.) using the instructions provided in section 6.6.
6. If "Overlay" is enabled, click on <**SaveClear**> to remove the data from previous sample(s) before scanning the next sample, if desired.

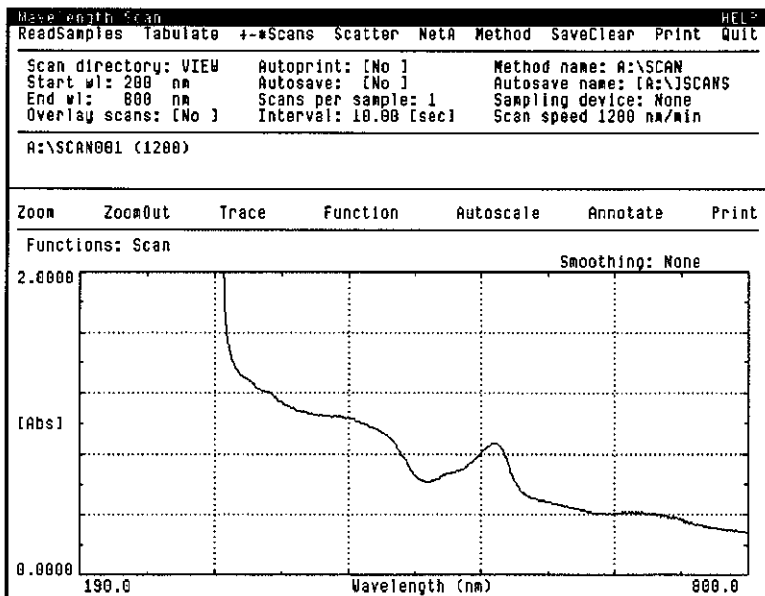

Figure 6-3. Wavelength Scan Window

6

- To scan the next sample, repeat steps 2 to 6.

The Save Clear window is displayed after 12 samples are read, unless "Autosave" or "Autoprint" are enabled. The scan data must be stored or cleared before additional samples can be scanned.

- To exit the Wavelength Scan mode when all spectra have been collected, click on <Quit>. The Quit window is displayed so the method and/or sample data can be stored. Then the Main window is displayed.

6.4 Analysis of Multiple Samples

Wavelength scanning analysis of multiple samples can be automated with the use of a multi-position Auto Cell Holder or one of the batch sampler. When analyzing multiple samples, special considerations should be given to the selection of the optimum analysis parameters.

If an Auto Cell Holder is used, the data can be stored automatically by setting "Autosave" to [Yes] and inputting a file name, or the user has the option of storing the data after they are collected. Regardless of whether they are stored with a permanent file name, they are stored with a temporary identification and can be manipulated after the analysis is complete.

If the batch sampler is used, "Autosave" can also be used to store the data, if sufficient memory exists. However, if "Autosave" is not enabled, the scan data are not stored and therefore the data must either be printed or output to the communications port as they are collected.

To print the data as they are collected, set "Autoprint" to [Yes] and verify that the Dot Matrix Printer is selected for "Send graph to" in the Printer and Plotter Configuration window. To format the data in the desired manner, the following should be considered:

If the data are to be plotted individually, set "Overlay" to [No]. To obtain the optimum plot, set "Autoscaling" to [Yes]. Peak pick can be selected on the Function window and printed with the spectral data.

If the data are to be overlaid, set "Overlay" to [Yes]. "Autoscaling" can also be set to [Yes] to obtain the optimum presentation. Peak, valley, and point pick cannot be selected. Spectra from 12 samples will be overlaid on a single plot, unless less than 12 samples were analyzed.

After the desired parameters are displayed on the Wavelength Scan window, samples can be run.

1. To read the blank:

Auto Cell Holder - Place the a cuvette of blank in the cell position that is in the light beam, then click on <<BLANK>>. The instrument blanks on the solvent.

Sipper/Batch Sampler - Aspirate and read the blank by pressing {FILL/BLANK}. The instrument blanks on the solvent.

NOTICE

If the blank solution has significant absorbance in the wavelength region of interest, the dynamic range of the instrument can be increased by setting the instrument gain for the blank. Instructions are provided in section 2.5.

2. To read the samples:

Auto Cell Holder - Place the input number of samples in the sampler and click on **<ReadSamples>**.

ISCO Sampler - Load the samples into the batch sampler, starting with the tube directly under the aspirator arm. Click on **<ReadSamples>**. The samples are read until the last position of the red rack is read.

Gilson Sampler - Program the Sample Controller with the rack type, number of tubes and orientation of the tubes. Load the samples in the programmed configuration. Click on **<ReadSamples>**. The analysis stops when the programmed number of tubes are read.

3. The samples are scanned and the data are displayed. The data may be stored or printed automatically, based upon the selections for "Autosave" and "Autoprint". A typical Wavelength Scan window with overlaid data from multiple samples is shown in Figure 6-4.

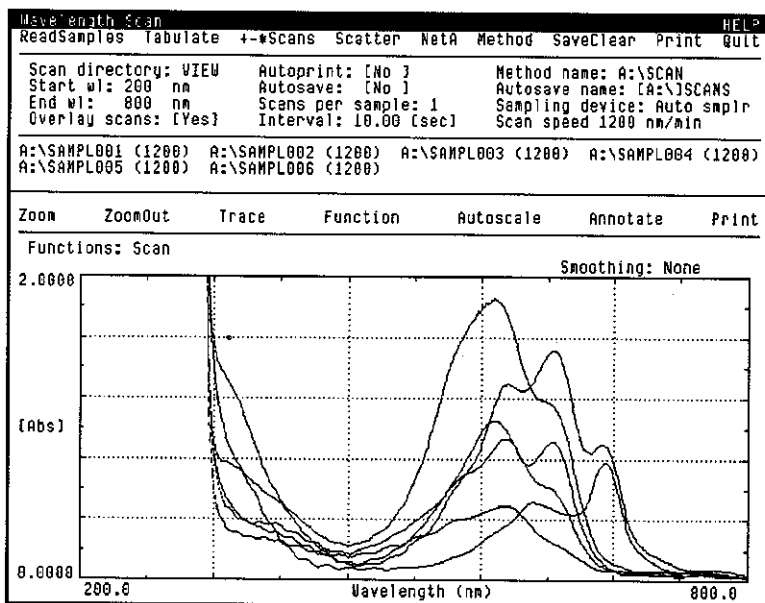

Figure 6-4. Wavelength Scan Window

4. If the data are stored, they can be manipulated using the instructions provided in section 6.5. **<Function>** can be used to display additional functions (derivative, peak pick, point pick, etc.) using the instructions provided in section 6.6.
5. If the Auto Cell Holder is used for the sampling device, and both "Autosave" and "Autoprint" are disabled, the Save Clear window is displayed after 12 samples are read. The scan data must be stored or cleared before additional samples can be scanned.
6. To exit the Wavelength Scan mode when all spectra have been collected, click on **<Quit>**. The Quit window is displayed so the method and/or sample data can be stored. Then the Main window is displayed.

6.5 Data Manipulation

To display stored scan file(s):

1. Before displaying stored scans, clear the display by clicking on **<SaveClear>**.
2. Verify that the desired "Overlay" selection is displayed.
3. To select the stored Scan file(s), click on "VIEW" following "Scan directory" to display the Scan Directory window.
4. Click on to highlight the desired file name(s), then click on [OK] to remove the directory window and display the scans. If "Overlay" is enabled, up to 12 file names can be selected. Once the scans are displayed, they can be manipulated using the instructions in this and the following section.
5. The scan speed is displayed following the scan file name on the Scan window.

The presentation of the spectral data can be optimized using the following features:

Ordinate label - The ordinate can be changed from absorbance to transmittance by clicking on the label.

Limit changes - The limits on the ordinate and/or wavelength axes can be changed by clicking on the displayed value and inputting the desired value.

Zoom - The "zoom" feature can be used to expand any portion of the graph. Click on **<Zoom>**, then click on two points on the graph to place crosses at the opposite corners of the area to be enlarged. When the second cross is clicked on, the graph is replotted. This can be repeated as often as desired. To return to the original plot, click on **<ZoomOut>**.

Trace - "Trace" can be used to display the ordinate value and the wavelength at any point on the plot. Click on **<Trace>**. Then move the arrow to the point of interest on the plot and click on the center mouse button to place a vertical line on the spectrum. The values at the place where the vertical line is placed are displayed in the upper right-hand side of the window. To move the vertical line to either the right or left, click on the right or left mouse button, respectively, with the arrow placed anywhere on the plot. To move to a different position on the spectrum, position the

arrow and click on the center mouse button. An asterisk after the reading indicates that it is out of range.

NOTICE

The digital data at all wavelengths are displayed in the Tabulate window.

Autoscale - Automatically scale the ordinate axis. This command does not change the wavelength limits.

Annotate - The data can be annotated by clicking on **<Annotate>**. Then, click on the graph to position a cross and input information from the alphanumeric keypad or keyboard. Up to four annotations can be placed on the graph. The annotations are printed with the window, but are not stored with the data.

Smoothing - Selection of the number of data points to use for smoothing affects the peaks that are picked by the instrument. If too few points are used, extraneous or insignificant peaks are picked. If too many points are used, real peaks are flattened or lost. Click on the displayed smoothing value and input different values, visually examining the data to determine the optimum smoothing value.

6.6 Function Selection

The Function Selection window, Figure 6-5, is used to select derivative or log spectral display and to select peak, valley and/or point pick tabulation. It is displayed when <Function> is clicked on from the Wavelength Scan window, or "VIEW" from the Method window.

Wavelength	Use	Wavelength	Use
200.0	[No]	500.0	[No]
250.0	[No]	550.0	[No]
300.0	[No]	600.0	[No]
350.0	[No]	650.0	[No]
400.0	[No]	700.0	[No]
450.0	[No]	750.0	[No]

Figure 6-5. Function Selection Window

To select the desired function(s):

1. Verify that the data from the desired sample(s) are displayed on the Wavelength Scan window.
2. Click on <Function> to display the Function Selection window.
3. Click on to darken the box to select the desired function(s).

Derivative and log - Click on to select the desired information to be plotted for the selected scan file. If "Overlay" is disabled, any number of selections can be made. If "Overlay" is enabled, only one selection can be made.

Peak / Valley Pick - Click on to select the feature and input the number of peaks and/or valleys to pick.

Range: 1 to 30 Default: 5

Point Pick - Click on to select the feature. Click on the displayed wavelength value(s) to input the desired value(s) and click on to change the "Use" column to [Yes].

4. When the selections are made correctly, click on <Exit> to remove the window from the display.
5. Example data, plotted with the selections in the Function Selection window (Figure 6-5), are shown in Figure 6-6.

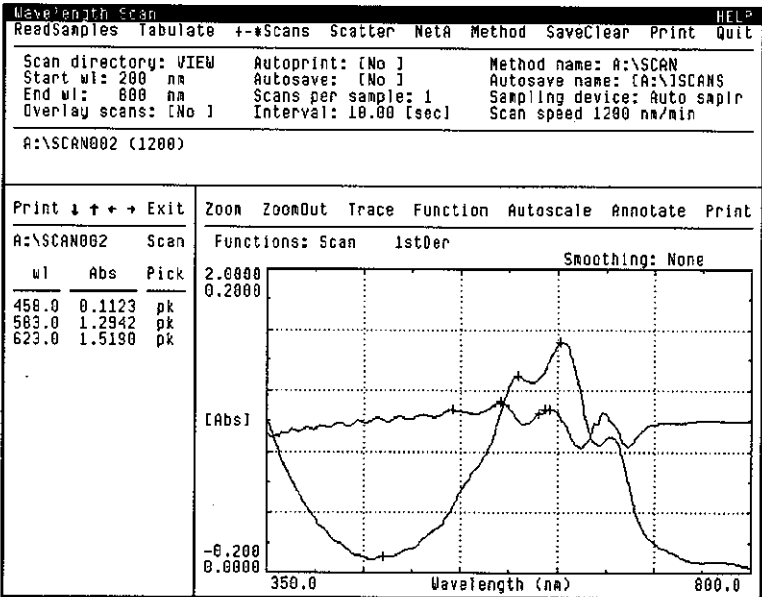

Figure 6-6. Wavelength Scan Window with Multiple Functions

The ordinate axis labels for the different selections are stacked on the left-hand side of the plot. The labels can be changed using the instructions in section 6.5.

The peak pick data for the absorbance scan is displayed. To display the peak pick data for the first or second derivative, click on <=>, located in the menu bar above the peak pick data.

6.7 Tabulated Data

To print the absorbance value and corresponding wavelength at each point in the spectrum, click on <Tabulate>. The first 11 data points from a typical spectrum are shown in Figure 6-7.

Tabulation for Scan File: A:\SCAN001	
wl	Abs
200.0	0.1122
201.0	0.1036
202.0	0.0965
203.0	0.0904
204.0	0.0829
205.0	0.0757
206.0	0.0691
207.0	0.0630
208.0	0.0574
209.0	0.0526
210.0	0.0485

Figure 6-7. Tabulated Scan Data

6

6.8 Spectral Addition, Subtraction and Multiplication

Spectra that have been stored can be scaled using a factor, then can be added, subtracted or multiplied. The $+-*$ Scans window, Figure 6-8, is used to select these calculations. It is displayed when $<+-*Scans>$ is clicked on from the Wavelength Scan window.

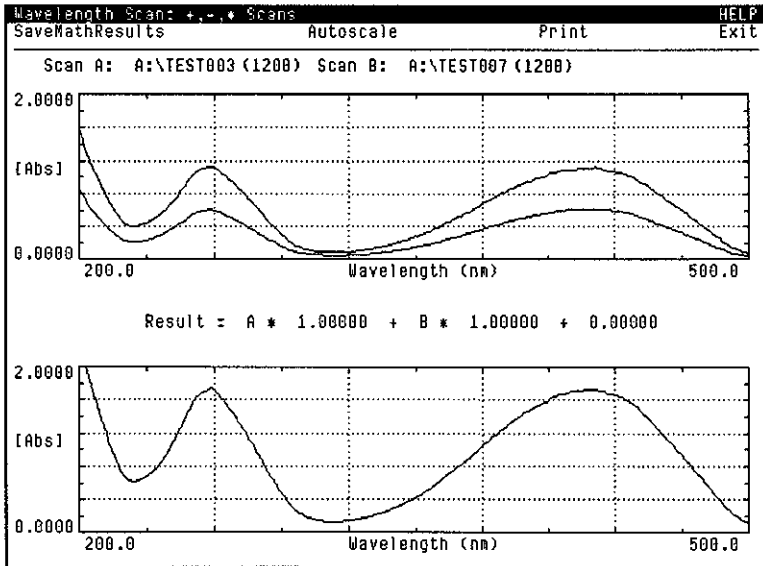

Figure 6-8. $+-*$ Scans Window

The $+-*$ Scans window has two graphic portions. The upper graph is used to display the raw data for the two spectra. The lower graph displays the resultant spectrum.

To perform the manipulation:

1. To input the file name for the first spectrum, A, click on "Scan A". The Scan Directory window is displayed. Click on the desired file, then [OK]. The spectrum is displayed.
2. Repeat step 1 to select the file for scan B.
3. The format of the spectra can be changed by clicking on the ordinate label and the ordinate and wavelength axis limits, and inputting the desired values.

- To input the calculation parameters, click on "Result" in the middle of the window to display the $+,-,*$ Parameters window, Figure 6-9.

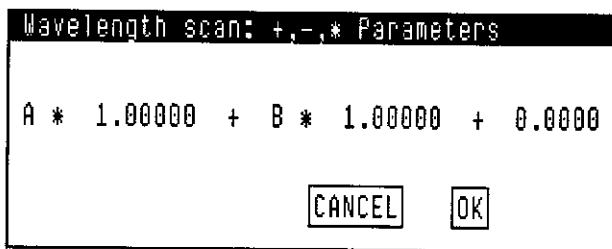

Figure 6-9. $+,-,*$ Parameters Window

- Three factors can be input in the window. These are a scaling factor for Scan A, a scaling factor for Scan B, and an additional value that is added to (subtracted from or multiplied by, depending upon sign) the results. Click on each of these factors and input the desired value.
- Whether the spectra are added, subtracted or multiplied is determined by the sign. Click on to toggle between + (for addition), - (for subtraction), and * (for multiplication).
- When the desired parameters are displayed, click on [OK] to use the equation and remove the $+,-,*$ Parameters window from the display.
- The equation and the resultant spectrum are displayed in the lower graph. The format of the spectrum can be changed by clicking on the function, ordinate or wavelength axis limits and inputting the desired values.
- To store the resultant spectrum, click on <SaveMathResults> to display the Save Results window. Input the desired file name, then click on [OK] to remove the window and store the data.
- To print the window, click on <Print>.
- To exit the $+,-,*$ Scans window and return to the Wavelength Scan window, click on <Exit>.

6.9 Scatter Correction

The Scatter window, Figure 6-10, is used to correct a stored spectrum for scatter. It is displayed when <Scatter> is clicked on from the Wavelength Scan window.

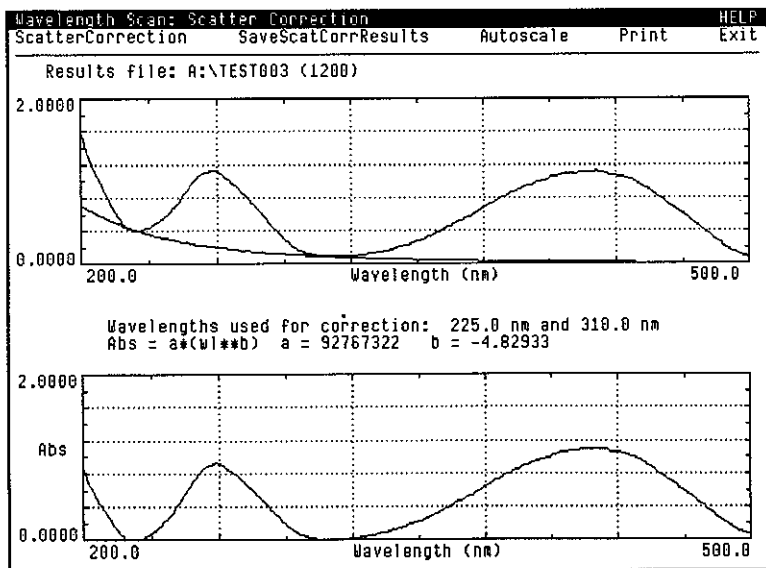

Figure 6-10. Scatter Window

The Scatter window has two graphic portions. The upper graph is used to display the uncorrected spectrum and the scatter component. The lower graph displays the spectrum corrected for scatter.

To correct for scatter:

1. Click on "Scan file". The Scan Directory window is displayed. Click on the desired file, then click on [OK]. The spectrum is displayed on the upper graph.
2. The format of the spectrum can be changed by clicking on the function, ordinate or wavelength axis limits and inputting the desired values.
3. Click on <ScatterCorrection>, then click on two points in the spectrum to place crosses where there is no sample absorption; that is, where all apparent absorption is due to scatter. When the second cross is clicked on, the calculation is performed. The scatter spectrum is displayed in the upper graph, the corrected sample spectrum is

displayed in the lower graph, and the equation for scatter correction is displayed in the middle of the window, along with the constants used to calculate the correction.

As an alternative, the wavelength values in the center of the window can be clicked on and new wavelength values input.

4. The format of the spectrum can be changed by clicking on the function, ordinate or wavelength axis limits and inputting the desired values.
5. To store the resultant spectrum, click on **<SaveScatCorrResults>** to display the Save Results window. Input the desired file name, then click on **[OK]** to remove the directory window and store the data.
6. To print the window, click on **<Print>**.
7. To exit the Scatter Correction window and return to the Wavelength Scan window, click on **<Exit>**.

6.10 Net Absorbance Calculations

The Net Absorbance Calculations window, Figure 6-11, is used to calculate net absorbance from a stored spectrum. Either one or two baseline points can be used. It is displayed when <NetA> is clicked on from the Wavelength Scan window.

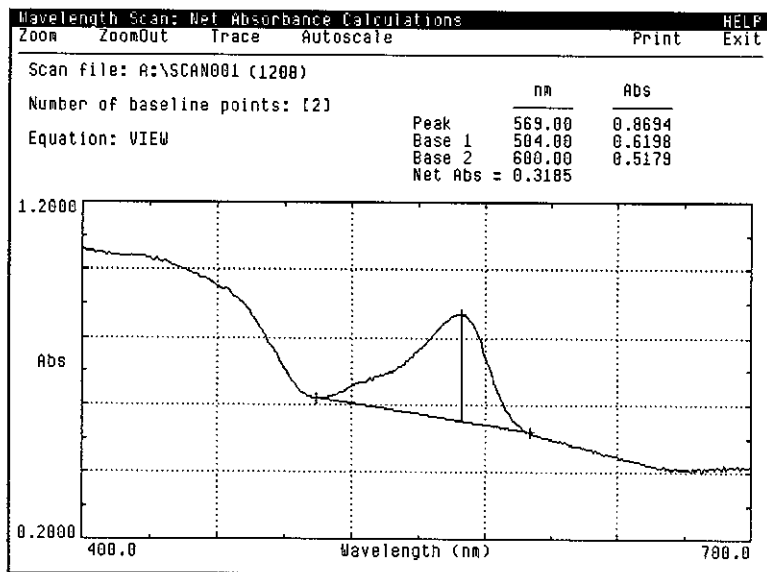

Figure 6-11. Net Absorbance Calculations Window

To calculate net absorbance:

1. Click on "Scan file". The Scan Directory window is displayed. Click on the desired file, then click on [OK]. The spectrum is displayed.
2. The format of the spectrum can be changed by clicking on the absorbance or wavelength axis limits and inputting the desired values. <Trace> and <Zoom> can also be used. Refer to section 6.5 for detailed instructions.
3. Select the desired number of baseline points by clicking on the value following "Number of baseline points" to change from [1] to [2].
4. If desired, the equation can be displayed by clicking on "VIEW" following "Equation".

5. The wavelength values for the peak and the baseline point(s) are displayed in a table at the top of the window. To input the desired wavelengths:

- a. Click on "**Peak**", "**Base 1**", or "**Base 2**" to select the desired point.
- b. Use the mouse buttons to position the "Trace" indicator at the desired wavelength on the graph:

Center mouse button - move to the data point closest to the position of the arrow.

Right mouse button - with the arrow positioned anywhere on the graph, move one data point to the right.

Left mouse button - with the arrow positioned anywhere on the graph, move one data point to the left.

The position of the "Trace" indicator line is shown in the table. As an alternative, the desired wavelength can be input in the table by clicking on the displayed wavelength value and inputting the desired wavelength value.

- c. Repeat steps a and b until the desired wavelengths are displayed.
 - d. Click above the graph on a blank part of the display to remove the trace line and accept the displayed wavelengths. The net absorbance value is calculated, and the lines indicating the points used in the calculation are placed on the spectrum.
6. Examine the data to verify that the desired points were selected. If desired, change any of the points, using the instructions in step 5, above.
 7. To print the window, click on **<Print>**.
 8. To exit the Net Absorbance Calculations window and return to the Wavelength Scan window, click on **<Exit>**.

6.11 Example Analyses

EXAMPLE 1

Obtain a spectrum of a purified protein sample. Find the absorbance maxima and tabulate the absorbance data at 230, 260, 280, and 320 nm. Store the sample spectrum in file "A:\BSA001".

SOLUTION

Collect the data on the Wavelength Scan window, as shown in Figure 6-12. Use the Function window to select Peak Pick and input the four wavelengths for Point Pick. Be sure to change the "Use" column to [Yes]. Use <<PrtScr>> to print the window, so that the point pick data are on the same printout as the spectral data.

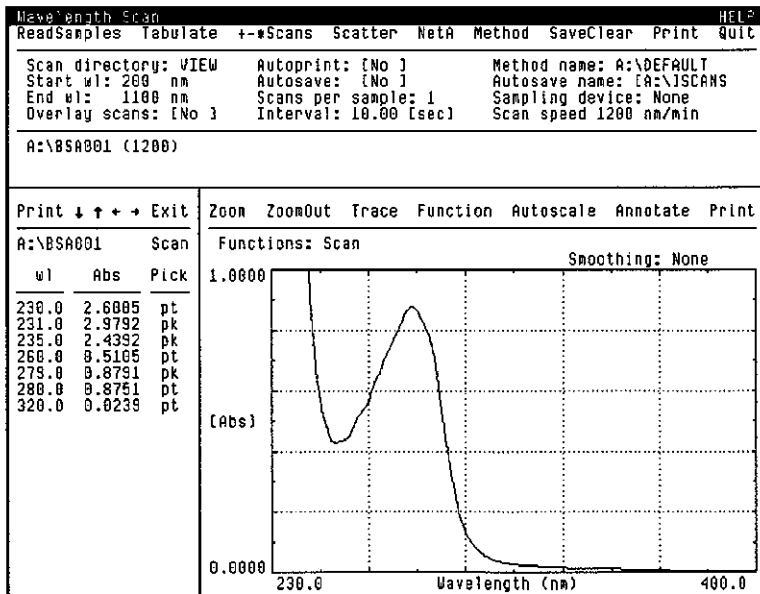

Figure 6-12. Sample Spectral Data with Point Pick

EXAMPLE 2

Display the spectrum shown in Example 1 with the first derivative overlaid.

SOLUTION

With the spectra displayed in Figure 6-12, click on <Function> to display the Function window. Click off "Peak Pick" and "Point Pick", and click on "1 Der". The overlaid spectra are shown in Figure 6-13. The absorbance axis limits are 0.0 to 1.0. The first derivative axis limits are -0.5 to 0.5.

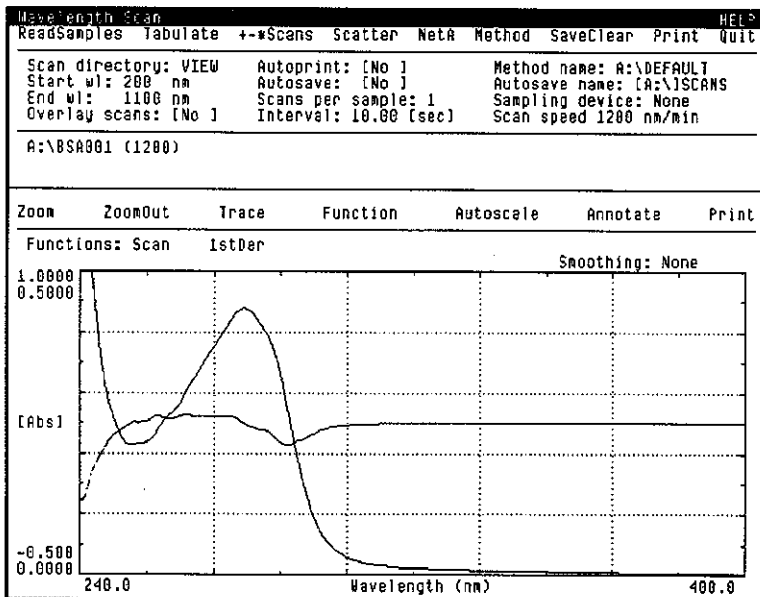

Figure 6-13. Overlaid Multifunction Spectra

6

EXAMPLE 3

An analgesic sample contains 12.5 $\mu\text{g/mL}$ caffeine. Subtract the caffeine from the sample spectrum. The sample spectrum is file "A:\SAMP001". The caffeine spectrum (25 $\mu\text{g/mL}$) is file "A:\CAFFN001".

SOLUTION

Use the +-* Window, shown in Figure 6-14. Input Scan A as "A:\SAMP001" and Scan B as "A:\CAFFN001". In the +-* Parameters window, input a factor of 1 for A, a factor of 0.5 for B, add a factor of 0, and set the first sign to "-".

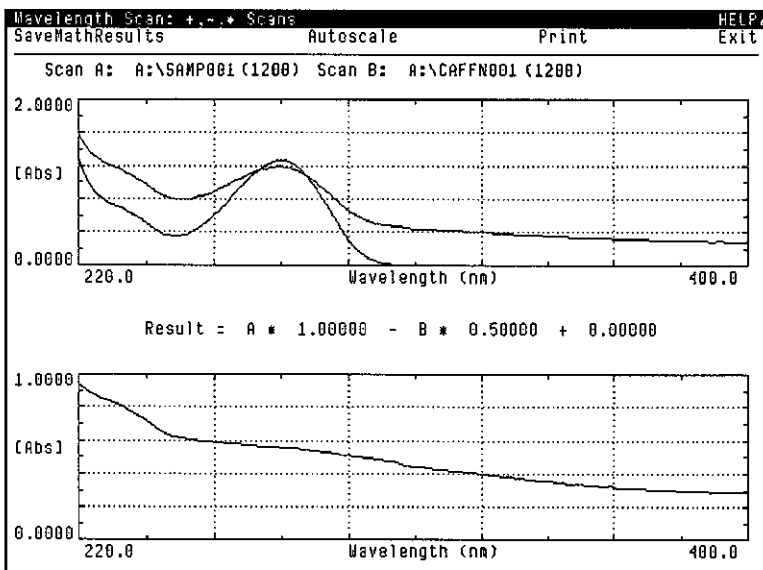

Figure 6-14. Component Subtraction

EXAMPLE 4

The resulting spectrum in Example 3 looks like scatter. Perform scatter correction on the sample spectrum.

SOLUTION

With the +-* Window displayed, click on <Exit> to display the Wavelength Scan window. Then click on <Scatter> to display the Scatter Correction window shown in Figure 6-15. Input the Scan file "A:\SAMP001". Click on <ScatterCorrection> and input wavelengths of 350 and 400 nm. The spectrum corrected for scatter is displayed on the lower part of the window.

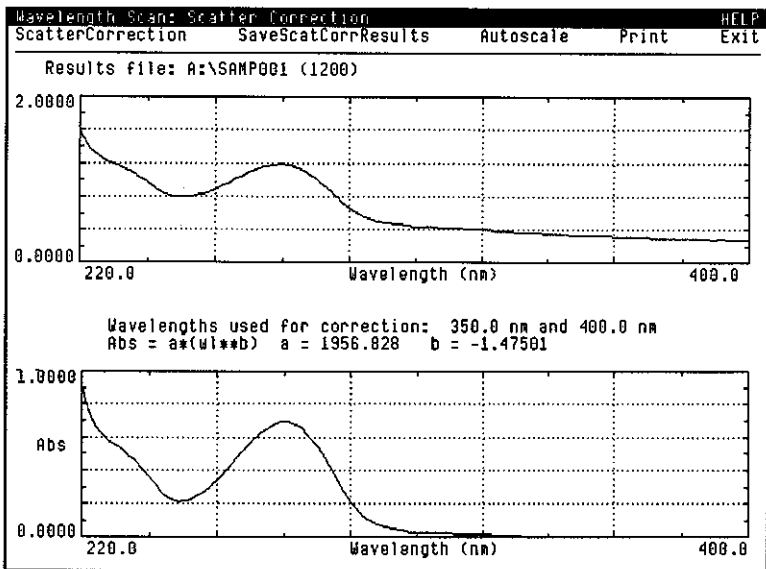

Figure 6-15. Caffeine Sample Corrected for Scatter

6.12 Data Output

Spectral data are output to the Communications port whenever an Output Data Type is selected in the Communications Configuration window. The type of data output is selected: "raw and calculated", "raw", or "calculated". General information on data output is provided in section 9.3.

In the Wavelength Scan mode, the same data are sent, regardless of which output type is selected. The data output is the wavelength, followed by the reading in either absorbance or transmittance, for the entire wavelength range.

The following is the output obtained for a scan from 200 to 210 nm in absorbance. The "User ID" is input in the Communications Configuration window. The "Method ID" is the method name. A <carriage return> and <line feed> are sent at the end of every line.

```
User ID: DU600
Method ID: A:\SCAN
Date: 10\09\91
Time: 10:38
200.000 0.112
201.000 0.103
202.000 0.096
203.000 0.090
204.000 0.082
205.000 0.075
206.000 0.069
207.000 0.063
208.000 0.057
209.000 0.052
210.000 0.048
```

6.13 Files

Two file types are created in the Wavelength Scan mode: method files and scan files. The method files are stored in the SCAN_M directory with the .APX extension. Method files are ASCII files and cannot be converted to the Lotus format.

The scan files are stored in the SCAN_D directory with the .SCN extension. They contain scan parameters and data at every wavelength in the scanned range.

6.14 ASCII Format

The ASCII file for a wavelength scan consists of two parts: analysis parameters and sample data.

The sample data include the wavelength, followed by the reading in either absorbance or transmittance, for the entire wavelength range.

The following ASCII file was converted from an absorbance scan from 200 to 210 nm.

Start Wavelength:	200.0000
End Wavelength:	210.0000
Read Mode:	ABS
Read Average:	0.1000
Nanometer Interval:	1.0000
Time:	0.0000
200.0000	0.1122
201.0000	0.1036
202.0000	0.0965
203.0000	0.0904
204.0000	0.0829
205.0000	0.0757
206.0000	0.0691
207.0000	0.0630
208.0000	0.0574
209.0000	0.0526
210.0000	0.0485

6.15 Lotus Format

The Lotus file for a wavelength scan consists of two parts: analysis parameters and sample data.

The sample data start in row 11 and are stored in the following columns:

Column A Wavelength
Column B Reading in either absorbance or transmittance

The following Lotus file was converted from an absorbance scan from 200 to 210 nm.

	A	B	C	D	E	F		
1	Start Wavelength:	200						
2	End Wavelength:	210						
3	Read Mode:	ABS						
4	Read Average:	0.1						
5	Nanometer Interval:	1						
6	Time:	0						
7								
8								
	A	B	C	D	E	F	G	H
11	200	0.1122						
12	201	0.1036						
13	202	0.0965						
14	203	0.0904						
15	204	0.0829						
16	205	0.0757						
17	206	0.0691						
18	207	0.0631						
19	208	0.0574						
20	209	0.0526						
21	210	0.0485						

SECTION SEVEN

KINETICS/TIME

Kinetic data are collected in absorbance as a function of time. Multiple samples can be analyzed using an Auto Cell Holder, although the sampler is not required for kinetic analysis.

The data are plotted or tabulated as they are collected and are stored in the instrument memory. Single or multiple blanks can be specified. A second wavelength can be selected for background correction.

After data collection is complete, the user can calculate the rate of the kinetic reaction using a linear regression calculation over the desired time interval for the best fit straight line. Because the data are stored in memory, these calculations can be repeated until the optimum results are obtained.

7

7.1 Principles of Operation

Temperature Control

If the Temperature Controller is installed, temperature is controlled automatically in this mode. When <ReadSamples> is clicked on, the Temperature Controller is turned on and set to the input temperature. This allows time for the cell holder to equilibrate at the reaction temperature before [START] is clicked on. The cell holder can be pre-heated, if desired, using the Device Control window to turn on the Temperature Controller.

The cell holder changes temperature quickly. However, it takes about 10 minutes for the Temperature Controller to warm the solution in a standard cuvette from 25 to 37 degrees, because of slow heat transfer through the glass walls of the cuvette. Therefore, it is suggested that the solution be pre-warmed before being placed in the cell holder. The Temperature Controller can efficiently maintain the temperature of pre-warmed solutions.

Instrument Blank

The blank reading for the instrument should be taken on a cuvette filled with solvent (substrate) before the analysis begins. The solvent should be at the same temperature that the analysis will be performed.

Match Correction

When using an Auto Cell Holder, Match can be used to correct for differences in the cell positions by taking a zero reading at an input wavelength on each cell position (with a cuvette filled with blank solution and inserted into the Auto Cell Holder). When Match correction is enabled, all readings taken by the instrument will be corrected by the offsets displayed on the Match window. Match correction should be used with the Micro Auto-6 and the Micro Auto-12 Accessories.

Background Correction - Net Absorbance

It is possible to correct for raised or sloping baselines, which may be caused by turbidity in the sample, using background correction. The user can input one background wavelength for background correction. If a background wavelength is selected, the reading at the background wavelength is subtracted from the reading at the analytical wavelength to calculate a net absorbance reading, A_{na} .

$$A_{na} = A_a - A_{bk}, \quad (1)$$

where, A_a is the reading at the analytical wavelength and A_{bk} is the reading at the background wavelength. Match correction, if enabled, is performed on all cell positions prior to this calculation.

Blank Subtraction - Corrected Absorbance

Any number of blank(s) and sample(s), up to 12 total, can be analyzed and stored in the same Results file. The user specifies which are blanks and which are samples. If more than one blank is specified, the sample(s) that follow each blank will be corrected by the preceding blank.

When rate results are calculated, the blank solution reading is subtracted from the corresponding sample reading at each time point for every sample.

$$A = A_s - A_{bl}, \quad (2)$$

where, A is the corrected absorbance, A_s is the sample reading and A_{bl} is the blank solution reading at each time point. Match correction and/or background correction calculations are performed on both blanks and samples prior to this calculation.

Concentration Calculation

The corrected absorbance (A , equation 2) can be multiplied by a factor to calculate concentration, using the equation:

$$\text{Concentration} = A \times \text{Factor} \quad (3)$$

Rate Calculation

The rate is calculated using linear regression to determine the best fit of a straight line to the data, using the basic rate equation:

$$\text{Rate} = (A_2 - A_1) / (t_2 - t_1) \quad (4)$$

where, the rate is calculated in units of delta A /minute, the corrected absorbance (equation 2) is used for each of the absorbance readings, and the limits of the time interval are selected by the user. The rate is calculated for samples, only. The calculated line is displayed with the actual data so that the user can compare the calculated rate to the actual data. The variance is also calculated and displayed with the rate. The variance gives the user an indication of how well the data fit the calculated line.

Enzyme Activity Calculation

The rate can be multiplied by a user-input factor to convert it to enzyme activity or other concentration units.

$$\text{Enzyme Activity} = \text{Rate} \times \text{Factor}. \quad (5)$$

Data Storage

A single Results file can hold data from up to 12 samples; the number is input by the response to the "number of samples" parameter. Each sample is designated as a sample or a blank, using the "sample assignment" information on the data collection window, or on the Method window.

It is necessary to store data from various samples in the same Results file, if the analysis of the data requires that the data from the samples be compared. Also, data from blanks must be stored in the same file as the associated sample data.

Samples that are analyzed singly are added to the Results file until the input "number of samples" is reached. Then the Results file is complete.

When the Auto Cell Holder is used, "groups" of sample data will be added to the Results file until the input "number of samples" is reached. The size of the "group" is equal to the "number of cells" parameter set for the Auto Cell Holder on the Sampling Device window.

For example, if the "number of cells" is 4 and the number of samples is 12, the Auto Cell Holder will be used three successive times to analyzed four samples. Then the Results file is complete.

7.2 Parameter Setup

Click on "KINETICS/TIME" from the Main window to enter the analysis mode. The Plotting window, Figure 7-1, is displayed. The Plotting window is used to setup analysis parameters and display kinetic data graphically as they are collected. (There is another data collection window in the Kinetics/Time mode - the Tabulation window.)

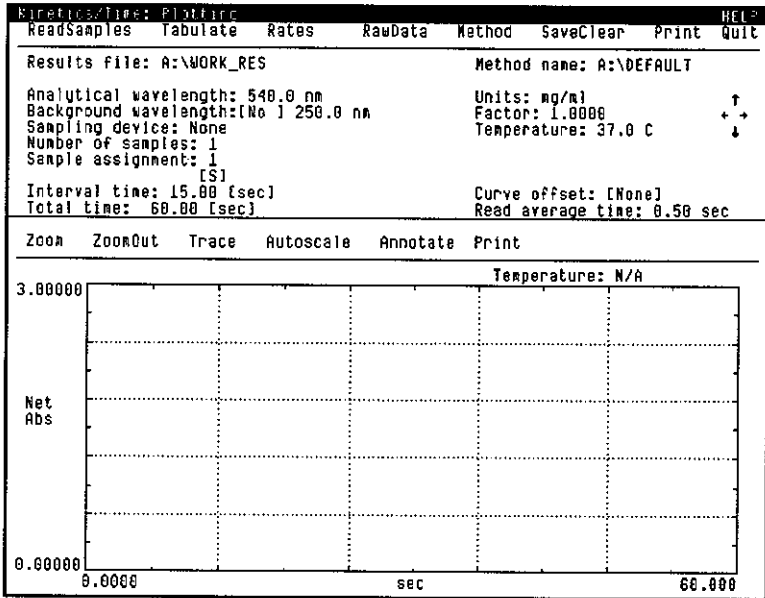

Figure 7-1. Plotting Window

Use the Method window to setup the analysis parameters:

1. Click on <Method> to display the Method window, Figure 7-2. The Method window is used to setup analysis parameters, recall stored methods and create new methods. General information on method windows is provided in section 3.8.
2. To recall a stored method, click on the desired method name in the listing at the top of the Method window.

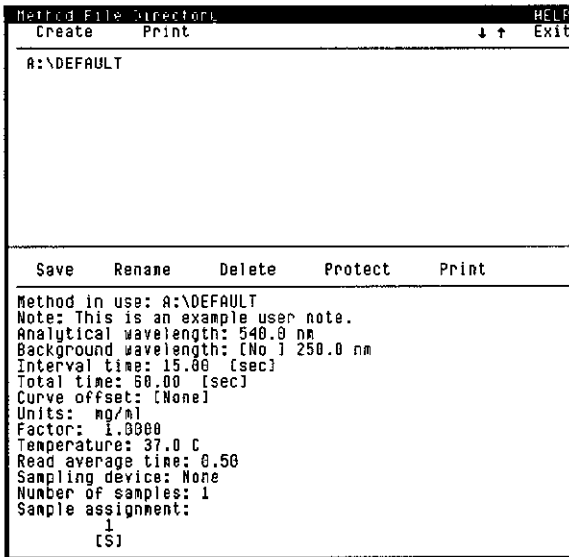

Figure 7-2. Method Window

3. The analysis parameters are displayed on the lower part of the Method window. Input the desired analysis parameters:

Method in use - This displays the name of the method that has been selected. If the method is protected, ****PROTECTED**** is displayed following the method name. If the method is protected, the analysis parameters cannot be changed. To input a new method name, click on **<Create>**.

Note - Click on to input a 40-character message that is used to described the method or procedure.

Analytical wavelength - The wavelength for data collection.

Background wavelength - The readings collected at the background wavelength are subtracted from the reading at the analytical wavelength to calculate the net absorbance. Toggle between **[Yes]** and **[No]** to enable or disable the correction.

Interval time - The time between successive readings of the same sample. The minimum time is affected by the number of cells and the read average time.

Using a read average time of 0.5 second, the following are the minimum interval times in seconds, based upon the type of Auto Cell Holder and the number of cells.

Auto 6 Cell Holder		Auto 12 Cell Holder			
Cells	Time	Cells	Time	Cells	Time
1	0.05*	1	0.05*	7	9.9
2	3.1	2	2.9	8	11.4
3	4.8	3	4.3	9	12.8
4	6.6	4	5.7	10	14.1
5	8.3	5	7.2	11	15.7
6	10.1	6	8.3	12	17.2

*A read average time of 0.05 second was used.

Total time - The instrument collects data until the total time has elapsed.

Curve offset - This parameter will automatically offset the first reading on each cell, so that the plotted data will not overlay. Toggle between [Ascending], [Descending] and [No] to enable or disable the offset. [Ascending] is for increasing reactions and [Descending] is for decreasing reactions.

Units - Input up to an 8-digit alphanumeric name for the enzyme activity units.

Factor - Input a factor to convert the absorbance to concentration units and the rate to enzyme activity.

Temperature - Input the operating temperature for the Temperature Controller, if used.

Read average time - The time, in seconds, that data are collected and averaged to take a reading. Ten sets of data are collected every second. If the interval time is less than 1 second, a read average time of 0.1 is always used.

Sampling device - Display the Sampling Device window for selection of the sampling device.

Number of samples - The number of sample data to be stored in a single Results file. If using the Auto Cell Holder, the "number of cells" input on the Sampling Device window cannot be greater than the input to this parameter. If it is greater,

then the input to this parameter is used for the "number of cells".

Sample assignment - Click on to identify the samples stored in a single Results file. [B] is for blank; [S] is for sample. The sample(s) following each blank will be corrected for that blank reading.

3. To store the analysis parameters in the selected method file, click on <Save>.
4. Click on <Exit> to display the Plotting window with the parameters from the selected method.

To input the desired parameters on the Plotting window:

1. The analysis parameters are listed near the top of the window. To change any of these, click on the parameter and input the desired value. A description of the parameters is provided above.
2. The absorbance limits are input by clicking on the displayed values on the graph and inputting the desired values.

7.3 Data Collection

The data can either be plotted or tabulated as they are collected. If the Plotting window is displayed and tabulation is desired, click on **<Tabulate>**. If the Tabulation window is displayed and a plot is desired, click on **<Plot>**. Either the Plotting or the Tabulation window can be used for data collection.

To collect data using the displayed analysis parameters:

1. Place a cuvette of substrate in the cell holder. Click on **<<BLANK>>**. The instrument blanks on the substrate.

Auto Cell Holder - Place a cuvette of substrate in the cell position that is in the light beam, then click on **<<BLANK>>**. The instrument blanks on the substrate.

2. If using the Auto Cell Holder, Match can be used to correct for slight differences in the cuvettes. Click on **<<MATCH>>** to display the Match window. Place a cuvette filled with substrate in each of the cell positions that will be occupied with a blank or sample. Take the readings and enable Match correction.

The cuvettes should not be removed from the instrument before the sample analysis. If the cuvettes are removed, it is necessary to return each cuvette to the same cell position in the same orientation. For most accurate results, Match correction should be repeated each time the cuvettes are removed from the instrument.

3. If the Plotting window is displayed, set the limits on the absorbance axis by clicking on the displayed value and inputting the desired value.
4. Click on **<ReadSamples>**. The Read Samples window is displayed, which is used to read the samples.

Insert sample(s)
Click on START when ready
Click on QUIT to stop

The Temperature Controller turns on, if not already on, and the temperature is controlled to the input temperature parameter. Wait

until the temperature display on the Temperature Controller reaches the desired temperature. (The actual temperature is placed on the Plotting window when [START] is pressed.)

5. Place a cuvette of sample in the cell holder and click on [START]. The data are plotted or tabulated as they are collected, depending upon the window.

Auto Cell Holder - Load the blank(s) and samples in the order indicated on the top of the window. Positions are indicated with a "B" for blank and a "S" for sample. Click on [START].

6. The analysis can be terminated at any time by clicking on [QUIT]. However, after [QUIT] is clicked on, no additional data can be added to the Results file, even if all the samples have not been analyzed.
7. When data collection is complete, if the total "number of samples" has not been analyzed, the window shown in step 4 is displayed. Repeat step 5, until all samples have been analyzed.

NOTICE

Do not change from the Plotting to Tabulation window, or display the Rates window until all samples have been analyzed.

8. When all the samples input for "number of samples" have been analyzed, the window shown in step 4 is removed. The data collection window can be changed from Plotting to Tabulation by clicking on <Tabulate>, or from Tabulation to Plotting by clicking on <Plot>. A typical Plotting window is shown in Figure 7-3. A typical Tabulation window is shown in Figure 7-4.

The data on the Plotting window can be reformatted and annotated. Detailed instructions are provided in the next section.

The net absorbance readings (equation 1) are tabulated on the Tabulation window. These readings have been corrected for background absorbance and Match correction, if used. All the raw data, plus additional calculated data are displayed on the Raw Data window.

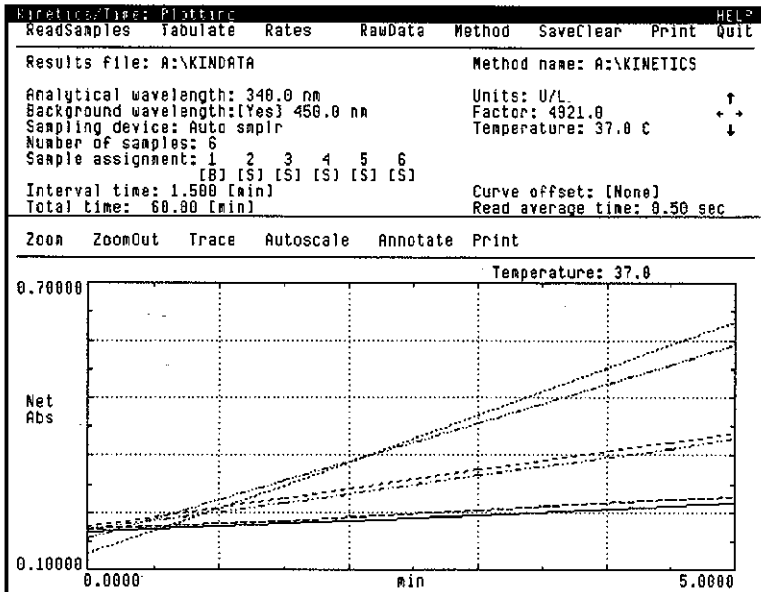

Figure 7-3. Plotting Window

Kinetics/Time: Tabulation HELP

ReadSamples Plot Rates RawData Method SaveClear Print Quit

Results file: A:\KINDATA Method name: A:\KINETICS

Analytical wavelength: 340.0 nm Units: U/L

Background wavelength:[Yes] 450.0 nm Factor: 4921.0

Sampling device: Auto sampr Temperature: 37.0 C

Number of samples: 6

Sample assignment: 1 2 3 4 5 6

[B] [S] [S] [S] [S] [S]

Interval time: 1.500 [min] Curve offset: [None]

Total time: 60.00 [min] Read average time: 0.50 sec

Net Absorbance Readings

Cell # Sample ID Time min	1	2	3	4	5	6
0.000	0.1885	0.1857	0.1650	0.1927	0.1340	0.1852
1.500	0.1963	0.2395	0.2867	0.2496	0.2774	0.2023
3.000	0.2149	0.2995	0.4065	0.3108	0.4227	0.2245
4.500	0.2328	0.3540	0.5286	0.3672	0.5706	0.2470
6.000	0.2498	0.4144	0.6517	0.4302	0.7184	0.2675
7.500	0.2679	0.4729	0.7745	0.4901	0.8649	0.2911
9.000	0.2855	0.5306	0.8980	0.5537	1.0082	0.3094
10.500	0.3041	0.5906	1.0200	0.6169	1.1500	0.3296
12.000	0.3201	0.6482	1.1512	0.6776	1.2960	0.3528
13.500	0.3405	0.7064	1.2683	0.7386	1.4573	0.3749
15.000	0.3566	0.7656	1.3898	0.7988	1.5973	0.3965
16.500	0.3774	0.8199	1.5043	0.8577	1.7320	0.4174
18.000	0.3935	0.8772	1.6229	0.9220	1.8931	0.4377
19.500	0.4110	0.9363	1.7520	0.9797	2.0217	0.4581
21.000	0.4291	0.9914	1.8721	1.0418	2.1769	0.4798
22.500	0.4483	1.0519	2.0097	1.1035	2.3721	0.5010

Figure 7-4. Tabulation Window

9. The rates of the kinetic reactions are calculated using the Rates window, described in section 7.5.
10. When all data collection is complete, use the Device Control window to turn off the Temperature Controller. The fan will turn off about 5 minutes after the Temperature Controller is turned off.
11. To clear all sample data from the window or to store the data, then clear the window, click on <SaveClear>. The Save Clear window is displayed so the sample data can be stored. If the data are stored, no additional data can be placed in the Results file, even if all the samples have not been analyzed.

NOTICE

Results files can be recalled in the Enzyme Mechanism mode, if they are copied into the "MECH_D" directory. The File Utilities mode is used to copy files.

12. When the analysis is complete, click on <Quit>. The Quit window is displayed so the method and/or sample data can be stored. Then the Main window is displayed.

7.4 Plotted Data

The presentation of plotted data on the Plotting and the Rates windows can be optimized using the following features:

Limit changes - The limits on the absorbance and/or time axis can be changed by clicking on the displayed value and inputting the desired value.

Curves offset - If the plotted data for several samples overlay at the zero time point, the data can be offset by enabling the "Curves offset" parameter.

Zoom - The "zoom" feature can be used to expand any portion of the graph. Click on <Zoom>, then click on two points on the graph to place crosses at the opposite corners of the area to be enlarged. When the second cross is clicked on, the graph is replotted. This can be repeated as often as desired. To return to the original plot, click on <ZoomOut>.

Trace - "Trace" can be used to display the time at any desired position on the plot. Click on <Trace>. Then move the arrow to the point of interest in the plot and click on the center mouse button to place a vertical line on the plot. The values at the place where the vertical line is placed are displayed. To move the vertical line to either the right or left, click on the right or left mouse button, respectively, with the arrow placed anywhere on the plot. To move to a different position on the plot, position the arrow and click on the center mouse button. An asterisk after the reading indicates that it is out of range.

NOTICE

The digital data at all wavelengths are displayed on the Raw Data window.

Autoscale - Automatically scale the ordinate axis. This command does not change the time limits.

Annotate - The data can be annotated by clicking on <Annotate>. Then, click on the graph to position a cross and input information from the alphanumeric keypad or keyboard. Up to four annotations can be placed on the graph. The annotations are printed with the window, but are not stored with the data.

7.5 Rate Calculation

The Rates window is used for rate calculation. It displays the plotted data, corrected for the blank, and allows the user to input the necessary information to calculate the reaction rate between any two time points on the graph.

The Rates window, Figure 7-5, is displayed when <Rates> is clicked on from either of the data collection windows. The Results file cannot be changed on the Rates window, so verify that the desired Results file is displayed on the data collection window before displaying the Rates window. Information about the data in the selected Results file is displayed in the upper portion of the Rates window.

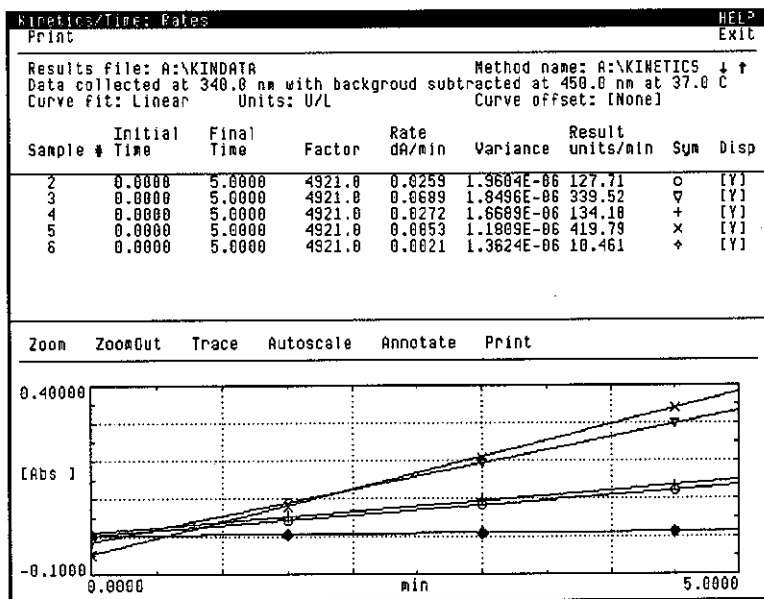

Figure 7-5. Rates Window

To calculate the rate of the kinetic reaction using the Rates window:

1. All sample data stored in the Results file are plotted. (Blanks are subtracted from the corresponding samples and not plotted.) Plotted data for any sample(s) can be deleted from the display by clicking on the [Y] in the "Disp" column in the table, replacing it with an [N] for "no".

2. The presentation of the plotted data can be optimized by using the curves offset, by using "zoom" or by changing the limits individually. Detailed instructions are provided in section 7.4.
3. The label on the ordinate axis can be changed from [Abs] to [Conc]. Concentration is calculated by multiplying the factor by each absorbance reading (equation 3).
4. The rates are calculated using the parameters input in the "Initial Time", "Final Time", and "Factor" columns. The time points can be found from the plotted data using Trace.

To input the same value for all cells, click on the column heading. Input the desired value in the displayed window and click on [OK]. To input different values for each cell, click on displayed value and input the desired value.

The line displayed on the graph is the slope of the line calculated from the initial and final time points. These times can be changed to optimize the fit of the calculated line to the collected data.

5. The tabulated results include the rate in delta A per minute (equation 4), the variance calculated for the curve fit, and the enzyme activity in the input units calculated from the factor (equation 5).
6. The table of rate results is printed by clicking on <Print>, located in the menu bar above the table. The plotted data are printed by clicking on <Print>, located in the menu bar above the graph. The entire display is printed by clicking on <<PrtScrn>>.
7. When the rates are calculated, click on <Exit> to return to the Plotting window.

7.6 Raw Data

The Raw Data window, Figure 7-6, tabulates the raw data at the analytical and background wavelengths, the net absorbance (background correction), and the corrected absorbance (blank subtraction). This window is displayed when <RawData> is clicked on from either of the data collection windows.

The Results file name cannot be changed on the Raw Data window, so verify that the desired Results file is displayed on the data collection window before displaying the Raw Data window. Information about the data in the selected Results file is displayed in the upper portion of the Raw Data window.

Kinetics/Time: Raw data							HELP
Print							EXIT
Results file: A:\KINDATA					Method name: A:\KINETICS		
					Data collected at 37.0		
Sample assignment: 1 2 3 4 5 6							
(0) (S) (S) (S) (S) (S)							
Time (min)	Sample ID	Analyt w/ 340.00nm	Bkg w/ 450.00nm	Net abs	Corrected Abs		
0.000	1	0.2952	0.1147	0.1805			
	2	0.2591	0.0734	0.1857			
	3	0.4249	0.2599	0.1650	-0.0055		
	4	0.3088	0.1882	0.1927	0.0122		
	5	0.4637	0.3498	0.1340	-0.0465		
	6	0.3076	0.1218	0.1852	0.0047		
1.500	1	0.3093	0.1129	0.1963			
	2	0.3147	0.0751	0.2395	0.0432		
	3	0.5379	0.2511	0.2867	0.0904		
	4	0.4364	0.1869	0.2496	0.0532		
	5	0.6280	0.3506	0.2774	0.0810		
	6	0.3273	0.1250	0.2023	0.0060		
3.000	1	0.3268	0.1119	0.2149			
	2	0.3701	0.0706	0.2995	0.0846		
	3	0.6602	0.2537	0.4065	0.1916		
	4	0.4978	0.1870	0.3108	0.0959		
	5	0.7724	0.3497	0.4227	0.2078		
	6	0.3471	0.1226	0.2245	0.0096		
4.500	1	0.3451	0.1123	0.2328			
	2	0.4289	0.0749	0.3540	0.1212		
	3	0.7794	0.2500	0.5286	0.2958		
	4	0.5571	0.1900	0.3672	0.1343		
	5	0.9187	0.3481	0.5706	0.3378		
	6	0.3671	0.1202	0.2470	0.0141		

Figure 7-6. Raw Data Window

To display the raw data and associated information:

1. The cell assignments for the Results file is displayed; they can be changed.
2. Only the first few readings are displayed. The other readings can be displayed by scrolling through the data, using the up and down arrows located in the upper right-hand corner of the window.

3. The tabular data include the net absorbance (equation 1) and the corrected absorbance (equation 2).
4. To print the window, click on **<Print>**. All data, even that which is not displayed because of insufficient room on the display, are printed on the printer.
5. When the Raw Data display is complete, click on **<Exit>** to return to the Plotting window.

7.7 Example Analyses

EXAMPLE 1

Setup the parameters for a kinetic analysis at 340 nm at 37°C. Analyze six samples, each with its own blank, using the Auto 6 Cell Holder. Take readings every 30 seconds for 5 minutes. Store the data in a file named "A:\CK_DATA".

SOLUTION

The analysis parameters are listed on the top of the Tabulation window, shown in Figure 7-7. The Auto 6 Cell Holder must be used twice to analyze all the samples. The data from the first three samples (with blanks) are tabulated on the window. The remainder of the samples will be analyzed subsequently, and stored in the same Results file.

Kinetics/Time: Tabulation							HELP
ReadSamples	Plot	Rates	RawData	Method	SaveClear	Print	QUIT
Results file: A:\CK_DATA				Method name: A:\CKTEST			
Analytical wavelength: 340.0 nm				Units: U/L			↑
Background wavelength:[No] 450.0 nm				Factor: 4921.0			↕
Sampling device: Auto sample				Temperature: 37.0 C			↓
Number of samples: 12							
Sample assignment: 1 2 3 4 5 6 7 8 9 10 11 12							
				Curve offset: [None]			
Interval time: 30.00 [sec]				Read average time: 0.50 sec			
Total time: 5.000 [min]							
Net Absorbance Readings							
Cell #	1	2	3	4	5	6	
Sample ID	1	2	3	4	5	6	
Time sec							
0.000	0.2139	0.2457	0.2283	0.2459	0.2107	0.2558	
30.000	0.2188	0.2451	0.2288	0.2429	0.2138	0.2567	
60.000	0.2188	0.2455	0.2276	0.2436	0.2194	0.2682	
90.000	0.2161	0.2490	0.2281	0.2470	0.2190	0.2654	
120.000	0.2107	0.2493	0.2297	0.2495	0.2196	0.2704	
150.000	0.2103	0.2525	0.2282	0.2532	0.2196	0.2760	
180.000	0.2115	0.2544	0.2294	0.2550	0.2198	0.2805	
210.000	0.2100	0.2578	0.2284	0.2584	0.2192	0.2868	
240.000	0.2106	0.2604	0.2294	0.2618	0.2195	0.2911	
270.000	0.2109	0.2624	0.2292	0.2644	0.2194	0.2979	
300.000	0.2113	0.2663	0.2299	0.2662	0.2198	0.3035	

Figure 7-7. Example Tabulation Window

EXAMPLE 2

After all the samples are analyzed, calculate the rate for the samples collected in Example 1, using the readings between 1 and 5 minutes. Use a factor of 4921 to calculate enzyme activity in units of U/L.

SOLUTION

With the Tabulation window displayed, click on <Rates> to display the Rates window, shown in Figure 7-8. Click on the headings for initial time, final time and factor and input the values of 1, 5, and 4921, respectively, to calculate the rates.

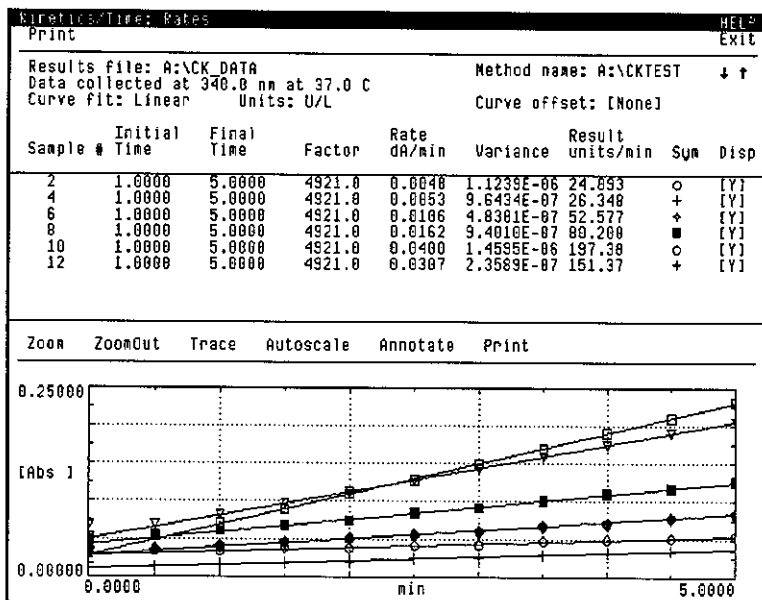

Figure 7-8. Example Rates Window

EXAMPLE 3

Setup the parameters for a kinetic analysis of one sample at 37°. Read at 340 nm and correct for background at 500 nm. Take readings as frequently as possible for 30 seconds. Store the data in a file named "B:\CK_FAST".

SOLUTION

The parameters are listed in the top of the Plotting window, shown in Figure 7-9. The data collected from the sample are plotted in the lower part of the window.

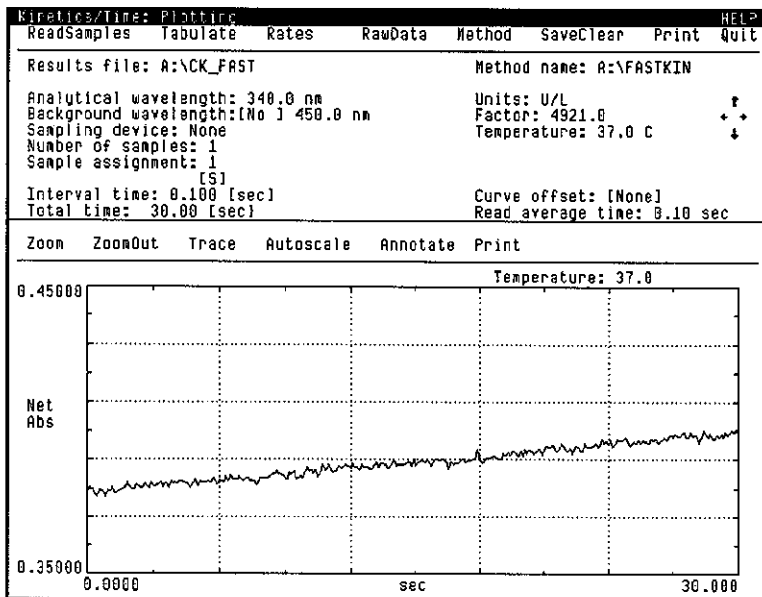

Figure 7-9. Example Plotting Window

7.8 Data Output

Data are output to the Communications port whenever an Output Data Type is selected in the Communications Configuration window. The type of data output is selected: "raw and calculated", "raw", or "calculated". General information on data output is provided in section 9.3.

In the Kinetics/Time mode, the order of the output for each data type is shown below. The "User ID" is input in the Communications Configuration window. The "Method ID" is the method name. A <carriage return> and <line feed> are sent at the end of every line.

Sample Data

If "raw and calculated" or "raw" is selected, the data output for each sample includes: sample number, time, and net absorbance. The following is the output obtained at the first two time points when the data in Figures 7-3 and 7-4 were collected. If "calculated" is selected, no information is sent.

```
User ID: DU600
Method ID: A:\KINETICS
Date: 10/09/91
Time: 11:08
1 0.000 0.1805
2 0.000 0.1857
3 0.000 0.1650
4 0.000 0.1927
5 0.000 0.1340
6 0.000 0.1852
1 1.500 0.1963
2 1.500 0.2395
3 1.500 0.2867
4 1.500 0.2496
5 1.500 0.2774
6 1.500 0.2023
```

Calculated Data at <Quit> or <SaveClear>

If either "raw and calculated" or "calculated" is selected, the rates information is sent each time the Quit window or the Save Clear window is removed from the display. If "raw" is selected, no information is sent.

The data output for each sample includes: sample number, initial time, final time, factor, rate, variance, and result. No data are sent for blanks. The following is the output obtained for the samples analyzed in the Rates window in Figure 7-5.

```
User ID: DU600
Method ID: A:\KINETICS
Date: 10/09/91
Time: 11:08
2 0.0000 5.0000 4921.0000 0.0259 1.9604E-06 127.712
3 0.0000 5.0000 4921.0000 0.0689 1.8496E-06 339.527
4 0.0000 5.0000 4921.0000 0.0272 1.6689E-06 134.180
5 0.0000 5.0000 4921.0000 0.0853 1.1809E-06 419.796
6 0.0000 5.0000 4921.0000 0.0021 1.3624E-06 10.4610
```

7.9 Files

Two file types are created in the Kinetics/Time mode: method files and data files. The method files are stored in the KIN_METH directory with the .APX extension. Method files are ASCII files and cannot be converted to the Lotus format.

The data files are stored in the KIN_DATA directory with the .DUF extension. They contain analysis parameters, rate data and sample data.

7.10 ASCII Format

The ASCII file for kinetics data consists of three parts: analysis parameters, rate data and sample data.

The rate data include: sample number, initial time, final time, factor, rate, variance and result. This is in the same format as the Rates window.

The sample data include the time, followed by: sample number, analytical absorbance, background absorbance (if enabled), net absorbance and corrected absorbance (samples, only.) This is in the same format as the Raw Data window.

The following ASCII file was converted from the data displayed in Figures 7-3 and 7-4. It includes the readings at the first two time points, only. The corresponding Rates window is Figure 7-5; the corresponding Raw Data window is Figure 7-6.

Analytical wavelength:	340.0000						
Background wavelength:	450.0000						
Background correction:	Yes						
Number of Samples:	6						
Sample assignment:	S	S	S	S	S	S	
Interval time:	1.5000 min						
Total Time:	60.0000 min						
Units:	U/L						
Factor:	4921.0000						
Temperature:	37.0000						
Curve offset:	None						
Read average time:	0.5000						
	1	0.0000	60.0000	4921.0000	0.0111	0.0001	54.4234
	2	0.0000	60.0000	4921.0000	0.0369	0.0002	181.5955
	3	0.0000	60.0000	4921.0000	0.0652	0.1016	320.6385
	4	0.0000	60.0000	4921.0000	0.0388	0.0007	191.1480
	5	0.0000	60.0000	4921.0000	0.0671	0.2096	330.3846
	6	0.0000	60.0000	4921.0000	0.0138	0.0000	67.7595
0.0000	1	0.2952		0.1147	0.1805	0.1805	
	2	0.2591		0.0734	0.1857	0.1857	
	3	0.4249		0.2599	0.1650	0.1650	
	4	0.3809		0.1882	0.1927	0.1927	
	5	0.4837		0.3498	0.1340	0.1340	
	6	0.3070		0.1218	0.1852	0.1852	
1.5000	1	0.3093		0.1129	0.1963	0.1963	
	2	0.3147		0.0751	0.2395	0.2395	
	3	0.5379		0.2511	0.2867	0.2867	
	4	0.4364		0.1869	0.2496	0.2496	
	5	0.6280		0.3506	0.2774	0.2774	
	6	0.3273		0.1250	0.2023	0.2023	

7.11 Lotus Format

The Lotus file for kinetics data consists of three parts: analysis parameters, rate data and sample data. The rate data are in the same format as the Rates window. The sample data are in the same format as the Raw Data window.

The rate data start in row 18 and are stored in the following columns:

Column A	Sample number
Column B	Initial time
Column C	Final time
Column D	Factor
Column E	Rate
Column F	Variance
Column G	Result

The sample data follow the rate data and are stored in the following columns:

Column A	Time data were collected
Column B	Sample number
Column C	Analytical absorbance
Column D	Background absorbance
Column E	Net absorbance
Column F	Corrected absorbance (samples, only.)

The Lotus file on the next page was converted from the data displayed in Figures 7-3 and 7-4. It includes the readings at the first two time points, only. The corresponding Rates window is Figure 7-5; the corresponding Raw Data window is Figure 7-6.

	A	B	C	D	E	F	G
1	Analytical wave	340					
2	Background wave	450					
3	Background corrYes						
4	Number of Sampl	6					
5	Sample assignmeS		S	S	S	S	S
6	Interval time:	1.5 min					
7	Total Time:	60 min					
8	Units:	U/L					
9	Factor:	4921					
10	Temperature:	37					
11	Curve offset:	None					
12	Read average ti	0.5					
13							
14							
15							
16							
17							
	A	B	C	D	E	F	G
18	1	0	60	4921	0.011059	0.000055	54.42343
19	2	0	60	4921	0.036902	0.000248	181.5954
20	3	0	60	4921	0.065157	0.101634	320.6384
21	4	0	60	4921	0.038843	0.000729	191.1480
22	5	0	60	4921	0.067137	0.209594	330.3845
23	6	0	60	4921	0.013769	0.000014	67.75947
24							
25	0	1	0.295150	0.114671	0.180478	0.180478	
26		2	0.259092	0.073417	0.185674	0.185674	
27		3	0.424870	0.259889	0.164981	0.164981	
28		4	0.380856	0.188184	0.192671	0.192671	
29		5	0.483736	0.349766	0.133970	0.133970	
30		6	0.307004	0.121845	0.185158	0.185158	
31	1.5	1	0.309255	0.112927	0.196327	0.196327	
32		2	0.314673	0.075137	0.239535	0.239535	
33		3	0.537874	0.251149	0.286724	0.286724	
34		4	0.436416	0.186863	0.249553	0.249553	
35		5	0.627980	0.350603	0.277376	0.277376	
36		6	0.327269	0.124955	0.202313	0.202313	

7

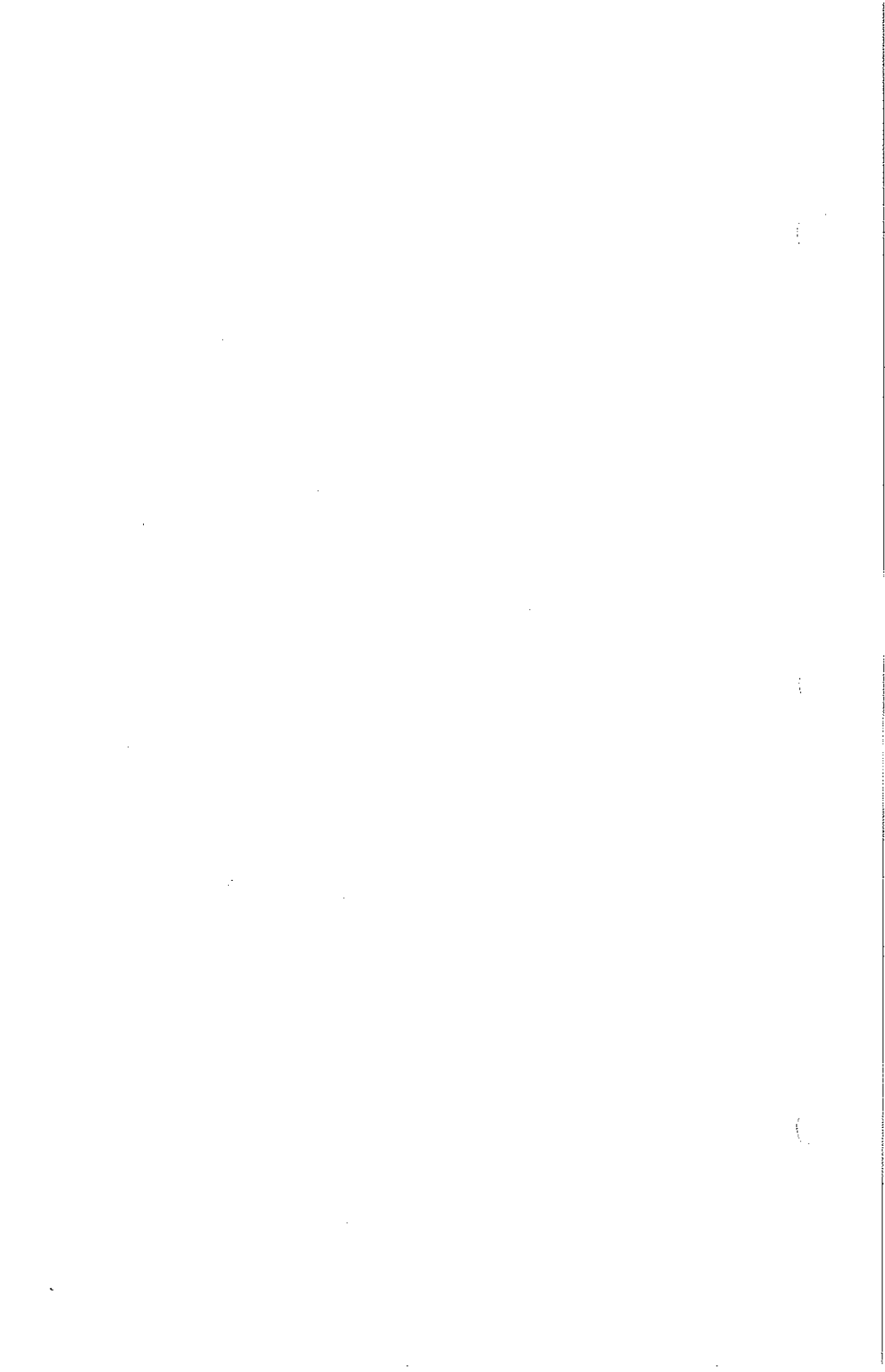

SECTION EIGHT

FILE UTILITIES

The File Utilities mode is used to rename, copy, move and delete files, to provide disk status, to format new floppy diskettes, to convert files stored in the instrument to Lotus¹ or ASCII format, to receive files from and send files to an external computer.

The DU Series 600 Spectrophotometer is supplied with internal RAM memory, which is used for storage. This location is called drive A. An optional 1 MEG RAM can be added to this memory in drive A. Drive B is an optional 3½ inch diskette drive, which will accept 720 kB diskettes.

NOTICE

As an alternative, DOS commands can be used on an IBM compatible computer to rename, copy, and delete files stored on diskettes generated by the DU Series 600 Spectrophotometer.

8

¹Lotus is a trademark of Lotus Development Corporation.

8.1 File Utilities Window

The File Utilities window, Figure 8-1, is displayed when "FILE UTILITIES" is selected from the Main window.

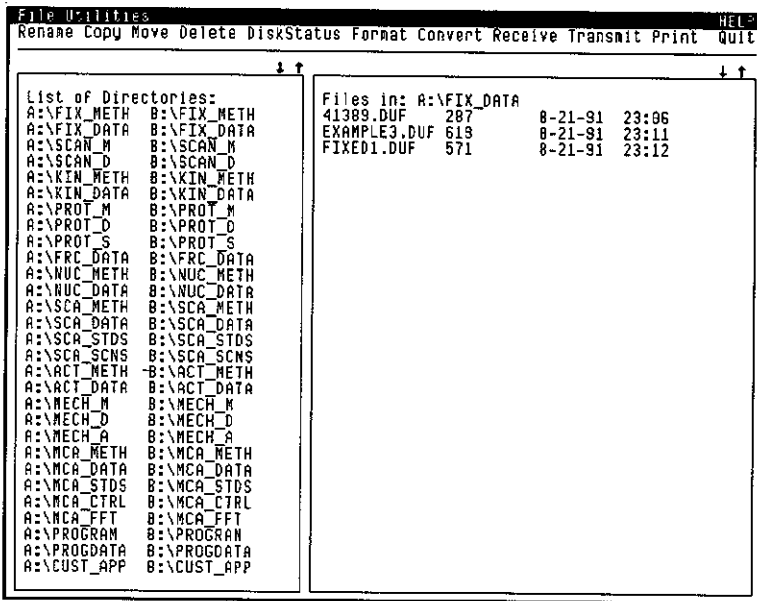

Figure 8-1. File Utilities Window

The menu bar commands for the File Utilities window are used to perform the various actions on a file. The instructions for each of these commands are given in the following sections.

The left-hand side of the window is used to display all the directories in the instrument. If optional application modes are installed, it may be necessary to scroll to display all the directories. The arrows in the upper right-hand corner of the window are used to scroll. When one of the directories is clicked on, the files in that directory are listed in the right-hand side of the window.

The desired file is selected from the file listing by clicking on the file name to highlight it. Clicking on a highlighted file name will remove the highlight. If the file listing fills the window, additional files can be displayed using the up/down arrows at the top right-hand corner of the window to scroll through the files.

8.2 Directories

The directories are created by the instrument as part of the format procedure (section 8.8) and are transparent to the user, except in the File Utilities mode. The user can neither create nor delete directories from the instrument.

Refer to the directory listing in Figure 8-1. Notice that each directory has a two-part name. The first part of the name identifies the operating mode; the second part of the name identifies the type of data. Also notice that there are identical directories for both drives A and B.

NOTICE

The instrument cannot read information stored in directories with names other than the ones listed.

The following tables explain the mnemonics used in the nomenclature.

Mnemonic	Mode
FIX	Fixed Wavelength
SCAN	Wavelength Scanning
KIN	Kinetics/Time
PROT	Protein Analysis
FRC	Fraction Read
NUC	Nucleic Acid
SCA	Single Component Analysis
ACT	Enzyme Activity
MECH	Enzyme Mechanism
MCA	Multicomponent Analysis
PROGRAM	Program mode - programs
PROGDATA	Program mode - data files
CUST_APP	Programs/Methods displayed on the Main window
LOTUS	Files converted to Lotus
ASCII	Files converted to ASCII
GELAR	Gel Scan Area
GELMW	Gel Scan Molecular Weights
GEL_SCNS	Gel data from either mode

Table 8-1. Directory Nomenclature - Mode Identifier

Mnemonic	Data Type
METH or M	Method
DATA or D	Data
STDS or S	Standards
SCNS	Scans
CTRL	Controls

Table 8-2. Directory Nomenclature - Data Type

8.3 Rename Command

To rename a file:

1. Display the File Utilities window by clicking on "File Utilities" from the Main window.
2. Click on the desired directory, listed on the left-hand side of the window. All the files in the selected directory are listed on the right-hand side of the window.
3. Click on the desired file to highlight it.
4. Click on <Rename>. The Rename File window, Figure 8-2, is displayed.

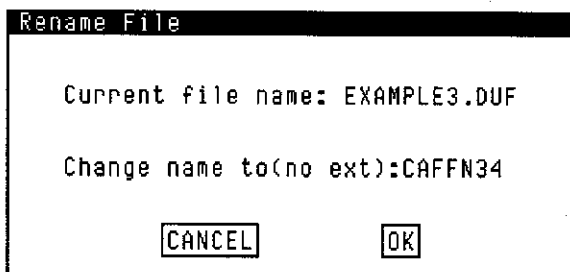

Figure 8-2. Rename File Window

5. The file name that was highlighted on the File Utilities window is displayed following "Current file name:".
6. Click on the file name following "Change name to(no ext):" and input the new file name using the alphanumeric keyboard. The instrument will automatically append the file name with the extension, so the file name must be input without the extension.
7. Click on [OK] to rename the selected file and remove the Rename File window from the display.

8.4 Copy Command

To copy a file from one directory to the same or other directory without changing the file name:

NOTICE

A file can be copied into any directory. However, the instrument is not able to read a file that is recalled in a different directory from which it was created. There are a few exceptions, which are noted in the respective operating mode section of this manual.

1. Display the File Utilities window by clicking on "File Utilities" from the Main window.
2. Click on the desired directory, listed on the left-hand side of the window. All the files in the selected directory are listed on the right-hand side of the window.
3. Click on one or more file names to highlight them.
4. Click on <Copy>. One of two Copy File windows is displayed, depending upon whether one or multiple files were highlighted.
- 5a. If one file was highlighted, the Copy File window, Figure 8-3, is displayed. Input the drive, directory and file name where the file is to be copied. Then click on [OK] to copy the selected file and remove the Copy File window from the display.

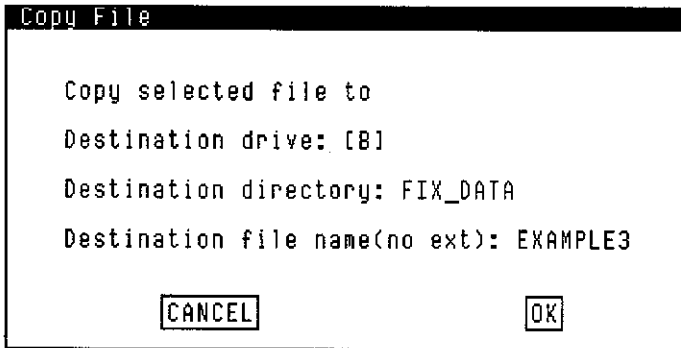

Figure 8-3. Copy File Window

5b. If multiple files were highlighted, the Copy Files window, Figure 8-4, is displayed. Input the drive and directory where the files are to be copied. The same file names are used. Then click on [OK] to copy the selected files and remove the Copy Files window from the display.

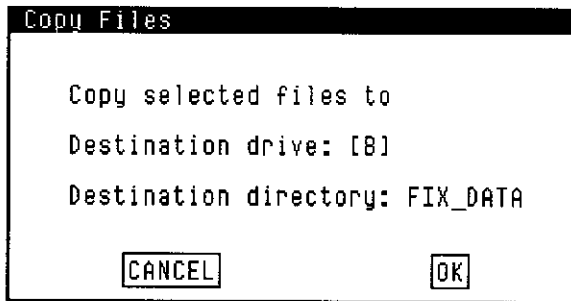

Figure 8-4. Copy Files Window

8.5 Move Command

To move one or more files from one directory to another without changing the file name(s):

NOTICE

A file can be moved into any directory. However, the instrument is not able to read a file that is recalled in a different directory from which it was created. A few exceptions are noted in the respective operating mode section of this manual.

1. Display the File Utilities window by clicking on "File Utilities" from the Main window.
2. Click on the desired directory, listed on the left-hand side of the window. All the files in the selected directory are listed on the right-hand side of the window.
3. Click on one or more file names to highlight them.
4. Click on <Move>. The Move File(s) window, Figure 8-5, is displayed. Input the drive and directory where the file(s) are to be moved. Then click on [OK] to move the selected file(s) and remove the Move File(s) window from the display.

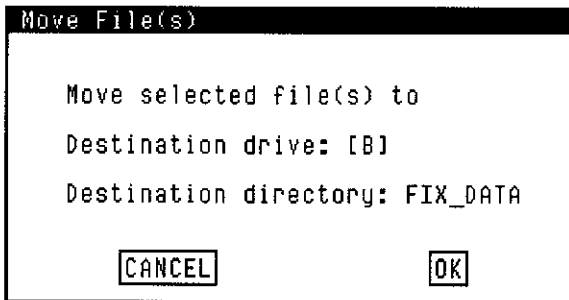

Figure 8-5. Move File(s) Window

8.6 Delete Command

To delete one or more files:

1. Display the File Utilities window by clicking on "File Utilities" from the Main window.
2. Click on the desired directory, listed on the left-hand side of the window. All the files in the selected directory are listed on the right-hand side of the window.
3. Click on one or more file names to highlight them.
4. Click on <Delete>. The Delete window, Figure 8-6, is displayed. Click on [OK] to delete the selected file(s) and remove the Delete window from the display.

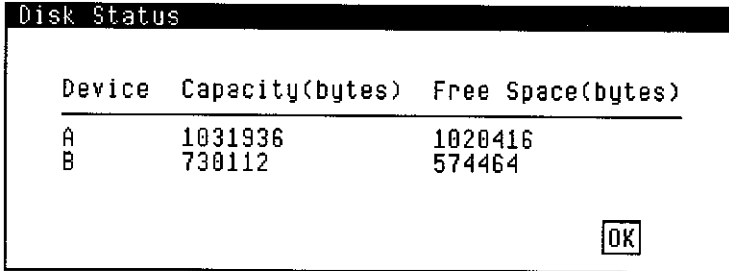

Figure 8-6. Delete File(s) Window

8.7 Disk Status Command

To display the amount of available space on each device:

1. Display the File Utilities window by clicking on "File Utilities" from the Main window.
2. Click on <DiskStatus>. The Disk Status window, Figure 8-7, is displayed. After reviewing the information, click on [OK] to remove the window from the display.



Device	Capacity(bytes)	Free Space(bytes)
A	1031936	1020416
B	730112	574464

OK

Figure 8-7. Disk Status Window

8.8 Format Command

The Format command formats the internal memory (Virtual Disk A) or a 3½ diskette using the standard DOS procedure and sets up the directories for subsequent file storage. All diskettes used with the DU-600 should be formatted using this command.

NOTICE

A diskette can be formatted on an external computer, using the DOS format command. After the diskette is formatted, the appropriate DU-600 directories (defined in section 8.2) must be added to the diskette before it can be used with the instrument.

The format a diskette:

1. Display the File Utilities window by clicking on "File Utilities" from the Main window.
2. Click on <Format>. The Format Disk window, Figure 8-8, is displayed.

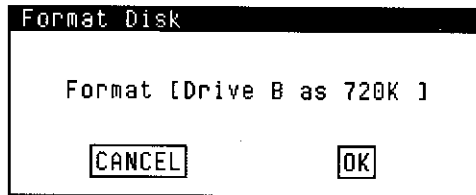

Figure 8-8. Format Disk Window

3. Verify that the proper drive and diskette size is displayed. The options are: [Virtual Disk A] and [Drive B as 720K]. Click on the displayed value to change it.

4. Click on **[OK]**. The following warning window is displayed.



5. Insert the diskette into the drive B. Click on **[OK]** to format the diskette. While the diskette is formatting, a window with the cylinder and head being formatted is displayed. When the formatting is complete, the directories are set up, then the window is removed. It takes about 3 minutes to format a diskette.

8.9 Convert Command

Files converted to Lotus format are stored in the LOTUS directory. Files converted to ASCII are stored in the ASCII directory. Files in these directories cannot be recalled by the instrument. The format of the data stored in these files is provided at the end of the appropriate operating mode section in this manual or an accessory manual.

To convert one or more files to Lotus or ASCII without changing file names:

1. Display the File Utilities window by clicking on "File Utilities" from the Main window.
2. Click on the desired directory, listed on the left-hand side of the window. All the files in the selected directory are listed on the right-hand side of the window.
3. Click on one or more file names to highlight them.
4. Click on <Convert>. The Convert Files window, Figure 8-9, is displayed. Input the drive where the file(s) are to be stored and select Lotus or ASCII format. Then click on [OK] to convert the selected file(s) and remove the Convert Files window from the display.

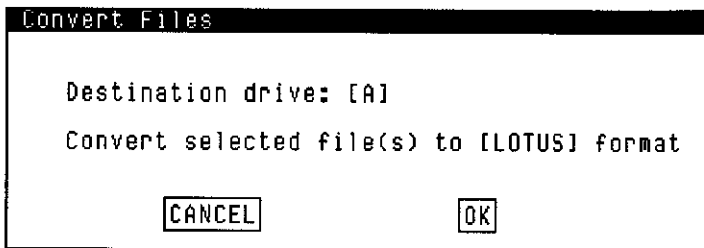

Figure 8-9. Convert Files Window

8.10 Receive File Command

To receive a file from an external computer through the Communications port and place it in the directory that is currently selected:

1. Display the File Utilities window by clicking on "File Utilities" from the Main window.
2. Click on the desired directory, listed on the left-hand side of the window.
3. Click on <Receive>. The Receive File window, Figure 8-10, is displayed. Input the directory, file name and the extension for the incoming file. The selections for the extensions are shown in Table 8-3.

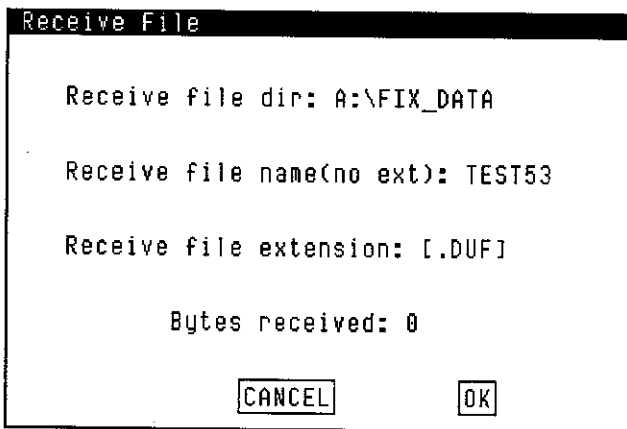

Figure 8-10. Receive File Window

Extension	File Type
.SCN	Wavelength scan data
.APX	Method or other text file
.DUF	Data file, consisting of data at selected wavelengths and calculated information.
.PGM	Program
.WKS	Lotus
.ASC	ASCII, converted from a .DUF file.
.FFT	Fourier transform data from Multicomponent Analysis mode.

Table 8-3. File Extensions

4. Click on **[OK]**. The cursor arrow will change to the hour glass and **[CANCEL]** on the bottom of the window will change to **[STOP RECEPTION]**.
5. Ready the external computer to send the file. Send the data to the instrument. As the data are received by the instrument, "Bytes received" on the Receive File window is updated.
6. When all the data have been sent to the instrument, click on **[STOP RECEPTION]** to remove the Receive File window.

8.11 Transmit File Command

The Transmit command is used to transmit a file to an external computer through the Communications port. This command is also used to print a file on the Dot Matrix Printer. Before transmitting files other than Method files to the Printer, do an ASCII conversion. Only Method files and ASCII-converted files can be printed.

1. Display the File Utilities window by clicking on "File Utilities" from the Main window.
2. Click on the desired directory, listed on the left-hand side of the window. All the files in the selected directory are listed on the right-hand side of the window.
3. Click on one or more file names to highlight them.
4. Click on <Transmit>. The Transmit File window, Figure 8-11, is displayed. Select either [Com/RS232 Port] or [Printer].



Figure 8-11. Transmit File(s) Window

5. Ready the external device to receive the file(s).
6. Click on [OK] to send the files. As each file is sent, the highlight is removed from the file listing. When all the files have been sent, the Transmit File window is removed.

SECTION NINE

DATA I/O

The Communications port is used to connect the instrument to an external computer. There are three uses for the communications port.

1. **Output Mode** - To output data as they are collected. The type of data output is selected in the Communications Configuration window. All collected data are output, as long as the output parameter is enabled. Instructions are provided in section 9.3.
2. **Remote Control** - To control the instrument remotely. Instructions are provided in sections 9.4 to 9.6.
3. **File Transfer** - To receive and transmit files that are stored in the instrument. Instructions are provided in sections 8.9 and 8.10, respectively.

9.1 Communications Configuration

The Communications Configuration window is used to set the communications parameters for the Communications port, to enable the Output mode, and to select the type of data output for all analysis modes of the instrument. This window is also used to select the parameters for the X-Y Plotter. Instructions for setting up the Communications Configuration window for use with the X-Y Plotter are provided in Manual 514523.

To display the Communications Configuration window, Figure 9-1, enter the Configuration mode by clicking on "Configuration" from the Main window to display the Configuration window, then click on <Communications> from the Configuration window.

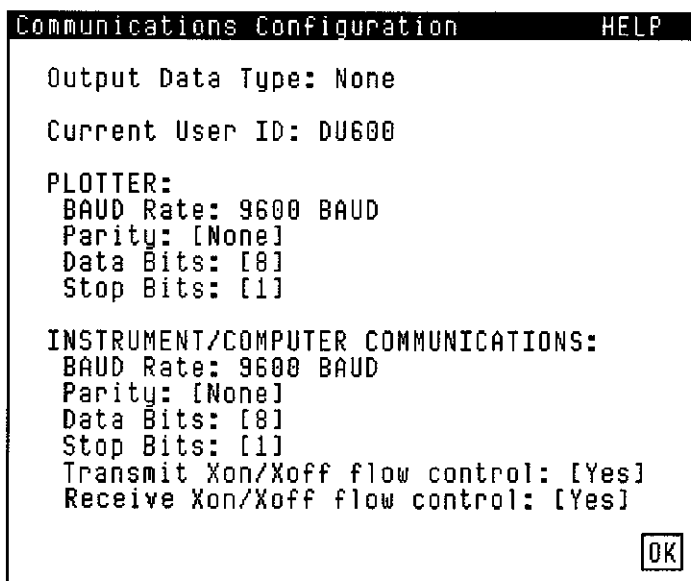

Figure 9-1. Communications Configuration Window

Input the following parameters:

1. **Output Data Type** - This is used to enable the Output mode. Click on to select [None], which is no output, or [Raw and calculated], [Raw] and [Calculated], which is the type of data sent to the Communications port. The format of the output data is described at the end section in this manual that describes the analysis mode.

2. **Current User ID** - Input an identification, which is transmitted in the Output mode at the beginning of each data set.
3. **Instrument Communications Parameters** - Set the following parameters, so that they are consistent with the remote device.
 - a. **Baud Rate** - Click on this parameter to display a window with the selections for baud rate. Click on the desired baud rate to select it, then click on [OK] to remove the window.
 - b. **Parity** - Toggle between [None], [Even], and [Odd] to set the parity.
 - c. **Data bits** - Toggle between [7] and [8] to set the number of data bits.
 - d. **Stop bit** - Toggle between [1] and [2] to set the number of stop bits.
 - e. **Transmit Xon/Xoff flow control** - Toggle between [Yes] and [No] to enable or disable transmission of Xon/Xoff.
 - f. **Receive Xon/Xoff flow control** - Toggle between [Yes] and [No] to enable or disable reception of Xon/Xoff.

NOTICE

When 7-bit data is being received and transmitted by the instrument, both flow control fields should be set to [Yes]. When 8-bit data is being received by the instrument, set "Transmit Xon/Xoff" to [Yes] and "Receive Xon/Xoff" to [No]. When 8-bit data is being transmitted by the instrument, set "Transmit Xon/Xoff" to [No] and "Receive Xon/Xoff" to [Yes]. Examples of 8-bit data include files with the following extensions: .WKS, .DUF, .SCN, .FFT, and .PGM.

When all the desired parameters are input, click on [OK] to store the entries and remove the Communications Configuration window from the display.

9.2 Diagnostics

Start Up Instructions

Use the following check list to verify that the Communications port is operational.

1. Verify that both the instrument and remote device have been powered up.
2. Verify that the remote device is configured as DTE - Data Terminal Equipment. (The DU-600 Spectrophotometer is configured as DCE - Data Communications Equipment.)
3. Select the communications parameters on the instrument (baud rate, parity, data bits, etc.), using the Communication Configuration window.
4. Configure the external device for the baud rate, number of data bits, number of stop bits, and the parity to correspond with the instrument.
5. Verify that the Communications port on the instrument is operational by performing the Loop Back Test.
6. Connect the external device to the Communications port using a cable. The COM port has a standard DB-25 male connector. A cable is not provided. However, one is available from Beckman, which has a standard DB-25 female connector for the DU Series 600 Spectrophotometer and a standard DB-25 male connector for the external device.

The following table shows the pin configuration of the DB-25 connector.

Pin Number	Circuit Description
1	Protective ground
2	Receive data
3	Transmit data
7	Signal ground

7. If the external device has output capabilities, verify that the instrument receives information sent to it by performing the Input Test.

Loop Back Test

To perform the loop back test on the Communications port:

1. Locate the Communications port on the back of the instrument. Disconnect the cable that is connected to it. See Figure 9-2. Insert the RS-232 Test Plug into the desired port. The RS-232 Test Plug is provided in the shipping kit with the instrument.

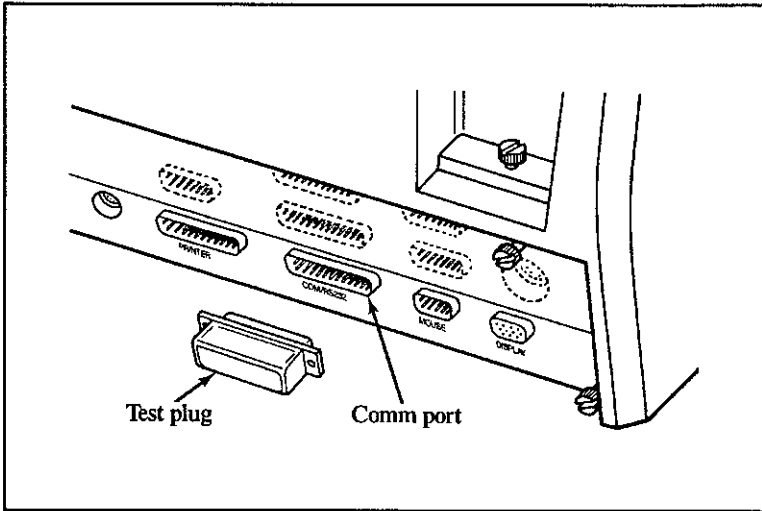

Figure 9-2. Communications Port

2. With the Main window displayed, click on "DIAGNOSTICS" to display the Diagnostics window. Then click on <LoopBack>, to display the Loop Back Tests window, Figure 9-3.

```
Loop Back Tests                                     HELP
RunRS232Loop  RunSamplerLoop  Print                Exit
-----
Note: Install the loop back connectors
      before running the tests.

[CommPort] Loop back test:
Batch Sampler Loop back test:
```

Figure 9-3. Loop Back Tests Window

3. If the desired RS-232 port is not displayed in brackets on the Loop Back Tests window, click on the bracketed selection to display the desired port, then click on **[OK]** to select the port and remove the window from the display.
4. Click on **<RunRS232Loop>**. The instrument automatically performs the test and displays the result, passed or failed, on the Loop Back Tests window.

NOTICE

If the test fails, the instrument is malfunctioning. Contact the local Beckman service office.

5. When the test is complete, click on **<Exit>** to return to the Diagnostics window.

Input Test

The RS-232 Input test verifies that the instrument is receiving the information sent by an external computer. The input test should be performed after the Loop Back test has verified that the Communications port on the instrument is operational. To perform the Input test:

1. Verify that the instrument and the external device have the same communication parameter settings (baud rate, parity, data bits, stop bits and Xon/Xoff). The Communications Configuration window is used to set the parameters on the instrument.
2. Locate the Communications port on the back of the instrument. Connect the external device to it.
3. With the Main window displayed, click on "DIAGNOSTICS" to display the Diagnostics window. Then click on **<RS232Input>** to display the RS232 Communications Input window, Figure 9-4. The bottom of the window is blank.

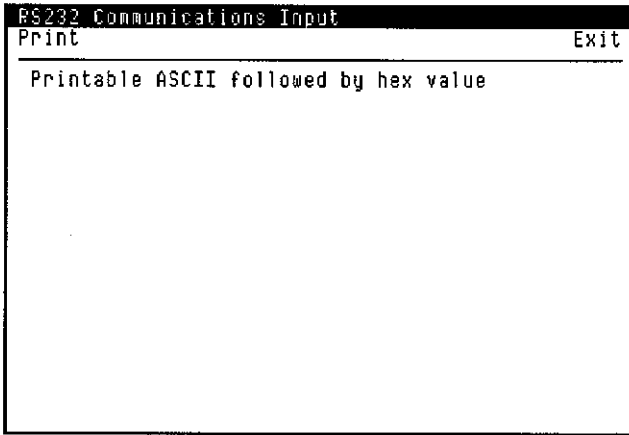

Figure 9-4.
RS232 Communications Input Window

4. Send an ASCII code from the external device to the DU-600 Spectrophotometer. The ASCII and corresponding hex value of the input received by the instrument are displayed.

NOTICE

If nothing is displayed, the external device is not communicating. Use the Loop Back Test to verify that the instrument Communications port is operational. If the wrong values are displayed, the communication parameters are probably different on the two devices.

5. When the test is complete, click on <Exit> to return to the Diagnostics window.

9.3 Output Mode

The Output mode is used to output data to the Communications port as they are collected by the instrument. The user can select to output only the raw data, only the calculated data, or both the raw and the calculated data. This data output selection is made on the Communications Configuration window, Figure 9-1. A description of the exact information that are sent for "raw", "calculated" and "raw and calculated" is provided near the end of each operating mode.

A header is sent prior to the data. The header consists of four lines, each followed by a carriage return and a line feed. The first line is the User ID, which is input in the Communications Configuration window. The second line is the Method ID, which is the method file which is used to collect the data. The third and fourth lines are the date and time, respectively.

9.4 Remote Control Mode

In the Remote Control mode, all instrument functions are controlled by a remote device through the Communications port.

NOTICE

Angle brackets "<" and ">" are used throughout this section to indicate the start and end of a remote command, respectively. These brackets are not part of the command and should not be sent with the command.

To operate the remote control mode:

1. Verify that the instrument and the external device are communicating. Refer to section 9.2 for additional information.
2. With the Main window displayed, click on "REMOTE CONTROL" to enter the Remote Control mode. A window with the message "Remote control operation, click on any button to quit" is displayed. No additional instrument function is required.

To enter the Remote Control mode from the remote device, *with either the Power Up Diagnostics window or the Main window displayed*, the remote device must send the following two ASCII codes to the instrument:

<ctrl W> <ctrl V>
or
(decimal 23) (decimal 22)

3. The instrument sends <r> <lf>, indicating that it is ready to receive remote commands from the remote device. The format for a remote command is:

<ascii string> <lf> ,

where, <ascii string> is a string of up to 40 ASCII characters, and <lf> is a line feed. The remote commands are described in the next section. All non-printing commands, other than <lf>, are ignored by the instrument.

4. When the instrument receives a command, it returns <s> <lf>, if it successfully executes the command. If the command cannot be executed, <f> <lf> or <p> <lf> is returned.

5. To exit the Remote Control mode from the instrument, click on a mouse button. A warning window is displayed. When [OK] is clicked on, the instrument sends <x> <lf>, indicating that the instrument is exiting the Remote Control mode.

To exit the Remote Control mode from the external device, send the <exit> command.

NOTICE

<lf> is <ctrl J>.

9.5 Remote Control Commands

The following are the remote commands that the instrument can recognize. Each command must be followed with a <lf>.

NOTICE

The remote commands frequently use values stored in the x-, y-, z- and t-registers in the stack. For simplicity, values stored in these registers are referred to as x-, y-, z- and t-values. That is, the x-value is the value stored in the x-register.

Math Commands

Command	Description
<number>	Any valid number. It is placed in the x-register.
<enter>	Push the stack. X-value goes to y-register, y-value goes to z-register, z-value goes to t-register, t-value is lost. Original x-value remains in x-register, and is overwritten when subsequent number is input.
<rotate>	Rotate all the values in the stack: t→z, z→y, y→x, x→t.

In/Out Commands

<rs232_out>	Send the x-value to the Communications port.
<rsbyte_out>	Convert the x-value to a single byte and send to the Communications port.

Spectro Commands

Command	Description
<source>	Turn on or off the desired source, determined by the x-value. If: x = 0, visible off, x = 1, visible on, x = 2, UV off, and x = 3, UV on.
<set_wl>	Set the wavelength to the x-value.
<set_rd_avg>	Set the read average to the x-value.
<blank>	Blank at the wavelengths given in registers 30 to 41. The x-value determines the total number of wavelengths.
<read_abs>	Take an absorbance reading using the <set_wl> and <set_rd_avg> values. Place the reading in the x-register. (Blank the instrument at the desired wavelength before taking a reading.)
<read_%T>	Take a transmittance reading using the <set_wl> and <set_rd_avg> values. Place the reading in the x-register. (Blank the instrument at the desired wavelength before taking a reading.)
<set_wl_range>	Set the wavelength range for scanning, where the lower wavelength is placed in the y-register and the upper wavelength is placed in the x-register.
<set_spd>	Set the wavelength scanning speed, determined by the x-value. If: x = 0, the speed is 120 nm/minute, x = 1, the speed is 240 nm/minute, x = 2, the speed is 600 nm/minute, x = 3, the speed is 1200 nm/minute, and x = 4, the speed is 2400 nm/minute.
<scan_blank>	Perform a blank scan over the designated wavelength range at the designated speed.

Command	Description
<scan_abs>	Perform an absorbance scan over the designated wavelength range at the designated speed. Place the readings in the designated ¹ buffer locations.
<scan_%T>	Perform a transmittance scan over the designated wavelength range at the designated speed. Place the readings in the designated ¹ buffer locations.
<send_scan>	Send the contents of the buffer ¹ to the remote device. The wavelength range is determined by <set_wl_range>.
<put_buffer>	Place the x-value in the buffer at the location determined by the y-value.
<get_buffer>	Find the value in the buffer location determined by the x-value and place it in the x-register.
<recv_file>	The file must be a Method file or a data file previously converted to an ASCII file. The command must be followed by a <space>, then the complete pathname of the file. The instrument will receive the file and store it in the designated location. The instrument expects to receive an EOF (hex 1a) to indicate the end of the file.
<wl_calib>	Perform a wavelength calibration.

¹ The readings from a wavelength scan are stored in buffer locations 1900 to 11000, which when multiplied by 0.1 represent the wavelength. At a scanning speed of 120 nm/minute, each buffer location is filled. At faster speeds, not all of the buffer locations will be filled. The locations that are filled are shown in the following table.

Scan Speed	Delta λ /Reading	Delta Buffer Locations
2400	2	20
1200	1	10
600	0.5	5
240	0.2	2
120	0.1	1

For example, the first five readings of a scan taken from 400 to 500 nm at 240 nm/minute are stored in buffer locations 5000, 4998, 4996, 4994, 4992.

Command	Description
<send_file>	The file must be a Method file or a data file previously converted to an ASCII file. The command must be followed by a <space>, then the complete pathname of the file. The instrument will send the designated file. The instrument will send an EOF (hex 1a) to indicate the end of the file.
<beep>	Make an audible beep.
<exit>	Exit the Remote Control mode.
<ex_mode>	Exit the Remote Control mode and display the first window of the analysis mode that is indicated by the mnemonic following this command. The analysis mode will operate in the normal manner. When operation of the analysis mode is complete and <Quit> is clicked on, the instrument will return to the Remote Control mode.

Mnemonic Analysis Mode

fix	Fixed Wavelength Wavelength Scan ²
kin	Kinetics/Time
prot	Protein Analysis
frac	Fraction Read/Plot
na	Nucleic Acid
sca	Single Component Analysis
em	Enzyme Mechanisms
ea	Enzyme Activity
mca	Multicomponent Analysis
gela	Gel Scan Area
gelm	Gel Scan Molecular Weights
pv	Performance Validation ³
diag	Diagnostics

²The Wavelength Scan mode cannot be entered from the Remote Control mode.

³In this mode only, the tests are performed automatically, the results are output to the printer, and the Remote Control mode is re-entered. About 75 minutes are required to complete the Performance Validation tests.

Command	Description
<set_output>	When using <ex_mode> to operate an analysis mode, this selects the output mode, determined by the x-value. If: x = 0, no output, x = 1, raw and calculated output, x = 2, raw data output, and x = 3, calculated data output.
<pwrup_res>	Send the instrument serial number and results of the Power Up Diagnostics to the remote device.

Register Commands

<store_reg> <#>	Store the x-value in the register designated by the number following this command.
<recall_reg> <#>	Recall the value stored in the register designated by the number following this command. Place the value in the x-register after "pushing" the register set.

Accessory Commands

<sip_fill>	Run the sipper pump in the forward direction for the time, in seconds, indicated in the x-register at the speed indicated in the y-register. (The speed range is 1 to 10, where 10 is fastest.) If the x-value is 0, the fill time input in the Accessory Configuration window is used. If the y-value is 0, then a speed of 5 is used.
<sip_return>	Run the sipper pump in the reverse direction for the time, in seconds, indicated in the x-register at the speed indicated in the y-register. (The speed range is 1 to 10, where 10 is fastest.) If the x-value is 0, the return time input in the Accessory Configuration window is used. If the y-value is 0, the speed is 5.
<adv_batch>	Advance the batch sampler one tube position.
<raise_arm>	Raise the batch sampler aspirator arm.

Command	Description
<lower_arm>	Lower the batch sampler aspirator arm.
<to_wash>	Move the batch sampler aspirator arm to the wash station.
<to_samp>	Move the batch sampler aspirator arm from the wash station back to the sample position.
<get_temp>	Read the current temperature and place it in the x-register.
<set_temp>	Turn on the temperature controller and set the temperature to the value currently in the x-register. If the value is outside the range of 10.0 to 90.0 (or 0.0 to 110.0 for the Tm cell holder), the temperature controller turns off.
<set_mm>	Move the transport to the millimeter position currently in the x-register.
<set_cell>	Move the transport to the cell position currently in the x-register. To home up the transport, place 13 in the x-register.
<sampler>	<p><u>8-channel Pump</u> - Control is based upon the x- and y-values, where:</p> <p style="padding-left: 40px;">x = 0 to stop the pump or 1 to start the pump</p> <p style="padding-left: 40px;">y = determines pump direction, where 0 is reverse (return) and 1 is forward (fill).</p> <p><u>16-position Valve</u> - Control is based upon the x- and y-values, where:</p> <p style="padding-left: 40px;">x = valve position from 1 to 16, and</p> <p style="padding-left: 40px;">y = 16.</p>

9.6 Remote Examples

EXAMPLE 1

Set up the instrument to take fixed wavelength readings at 280 nm every 10 seconds on a flowing sample and send the data to the remote device.

SOLUTION

The remote device must do the timing and request the readings. The following are the remote commands:

Command	Description
<1><lf>	Set the x-register to 1.
<set_rd_avg><lf>	Set the read average to 1 second.
<280><lf>	Set the x-register to 280.
<set_wl><lf>	Set the wavelength to 280.

Start blank solution flowing through the flowcell.

<280><lf>	Set the x-register to 280.
<store_reg><30><lf>	Store 280 in register 30.
<1><lf>	Set the x-register to 1.
<blank><lf>	Take a blank reading.

Start the sample flowing through the flowcell.

<read_abs><lf>	Take a sample reading.
<rs232_out><lf>	Send the sample reading to the remote device.

Repeat the last two commands every 10 seconds to take readings on the flowing sample.

EXAMPLE 2

Set up the instrument to take fixed wavelength readings at 260 and 280 nm on samples placed in the Auto 6 Cell Holder. Send the readings to the remote device.

SOLUTION

The following are the remote commands:

Command	Description
<260><lf>	Set the x-register to 260.
<store_reg><30><lf>	Store 260 in register 30.
<280><lf>	Set the x-register to 280.
<store_reg><31><lf>	Store 280 in register 31.
<1><lf>	Set the x-register to 1.
<set_rd_avg><lf>	Set the read average to 1 second.

Place blank solution in cell position 1.

<1><lf>	Set the x-register to 1.
<set_cell><lf>	Move to cell position 1.
<2><lf>	Set the x-register to 2.
<blank><lf>	Take a blank reading at the two wavelengths.

Place the first six samples in the Auto Cell Holder.

<260><lf>	Set the x-register to 260.
<set_wl><lf>	Set the wavelength to 260.
<read_abs><lf>	Take a sample reading.
<rs232_out><lf>	Send the sample reading to the remote device.
<280><lf>	Set the x-register to 280.
<set_wl><lf>	Set the wavelength to 280.
<read_abs><lf>	Take a sample reading.
<rs232_out><lf>	Send the sample reading to the remote device.
<2><lf>	Set the x-register to 2.
<set_cell><lf>	Move to cell position 2.

Repeat the above 10 steps, each time incrementing the <set_cell> command to move the transport.

EXAMPLE 3

Using a batch sampler, blank on the first tube and make a wavelength scan from 350 to 700 nm at 1200 nm/minute on the next three tubes. Send the data to the remote device.

SOLUTION

Command	Description
<350><lf>	Place 350 in the x-register.
<enter><lf>	Move it into the y-register.
<700><lf>	Place 700 in the x-register.
<set_wl_range><lf>	Set the wavelength scanning range from 350 to 700 nm.
<1><lf>	Place 1 in the x-register.
<set_spd><lf>	Set the scan speed to 1200 nm/minute.

These steps are for the blank.

<lower_arm><lf>	Lower the aspirator arm into the blank solution.
<8><lf>	Input 8 in the x-register.
<enter><lf>	Move it to the y-register.
<5><lf>	Input 5 in the x-register.
<sip_fill><lf>	Aspirate the blank for 5 seconds at a pump speed of 8.
<scan_blank><lf>	Scan the blank.
<raise_arm><lf>	Raise the aspirator arm.
<sip_return><lf>	Return the blank using the same time and speed as the fill.

Repeat the following steps for each sample.

<adv_batch><lf>	Advance to the next tube.
<lower_arm><lf>	Lower the aspirator arm into the first sample.
<sip_fill><lf>	Aspirate the first sample for 5 seconds at a pump speed of 8 (the values are still in the registers).
<scan_abs><lf>	Scan the first sample.
<send_scan><lf>	Send the scan for the first sample to the remote device.
<raise_arm><lf>	Raise the aspirator arm.
<sip_return><lf>	Return the sample.

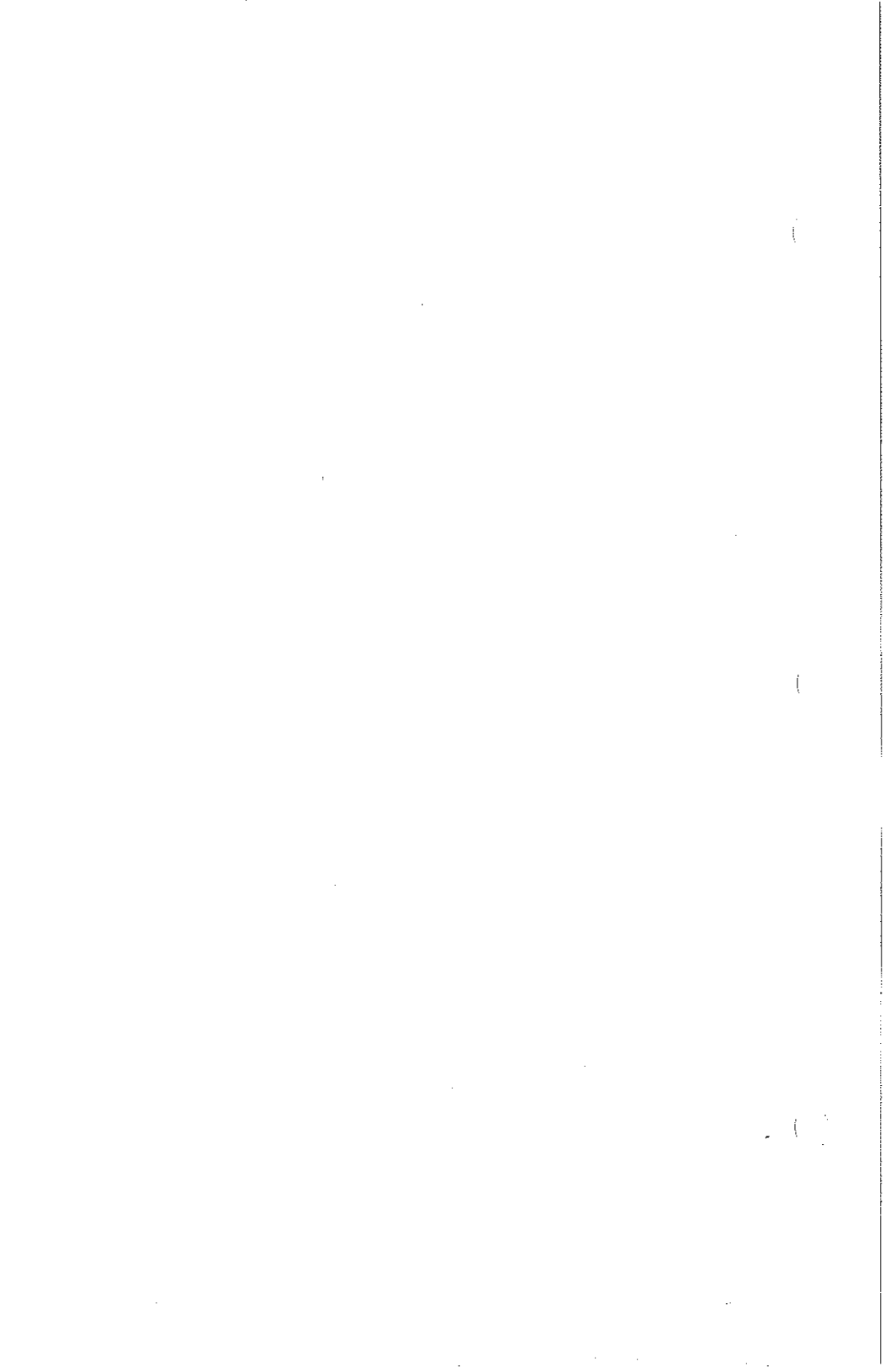

PREVENTATIVE MAINTENANCE

10.1 General Information

The DU Series 600 Spectrophotometer is a microprocessor controlled, optical instrument. For the microprocessor to operate properly, it is necessary to have adequate ventilation, as described in the installation instructions for the instrument, Manual 517315. It is necessary to operate the instrument below the specified maximum temperature of 40°C (104°F) for adequate cooling.

For the optical components to retain their quality, it is necessary to operate the instrument in a dust-free, non-corrosive environment. There can be situations where a spectrophotometer must be placed in a dust or corrosive environment. In this case, the optical surfaces must be cleaned or replaced periodically. Contact Beckman service for more information.

One component of the DU Series 600 Spectrophotometer that can be user-serviced to prevent an interruption in operation or increase performance is the UV source. With time, the output of the UV source gradually decreases. Typically, the output decreases to one-half the original level in 1000 hours of use. Decreased output from the UV source decreases the sensitivity of the instrument. This effect is wavelength dependent. If the sensitivity of the instrument decreases below the necessary level and the source has been on for 1000 or more hours, the UV source should be replaced, even if it is not burned out. The length of time that the UV source has been illuminated is displayed by clicking on **<Status>** from the Diagnostics window.

If the performance of the instrument remains satisfactory, the UV source does not need to be changed until it burns out. A burned out source is indicated by the "UV LAMP Failure" message.

Decreased output from the visible source is normally not significant enough to cause decreased sensitivity. However, if decreased sensitivity is observed in the visible range, the visible source should be checked for a brown film coating inside the lamp. To check the source, remove it using the instructions in section 12.3. If the lamp has a brown coating, replace it with

a new lamp. If the lamp is clear, it is operational. Replace the source, then peak it using the instructions in part II of section 12.3.

A service contract for this instrument is available from the Beckman field service representative.

10.2 Status Window

The Instrument Status window is used to display the cumulative total amount of time that the instrument has been turned on, the cumulative total amount of time that the UV source has been on (the time for the UV source can be reset in the Diagnostics mode when the source is replaced), the serial number of the instrument and the software revision.

To display the Instrument Status window:

1. With the Main window displayed, click on "DIAGNOSTICS" to display the Diagnostics window.
2. Click on <Status>. An Instrument Status window, similar to the one in Figure 10-1, is displayed.

```
Instrument Status
Print                               Exit
-----
ON TIME
Instrument: 50.2    hours
UV Source: 0.0    hours

SYSTEM
Instrument number: 4314547
Software version: A
```

Figure 10-1. Status Window

3. When the desired information is obtained, click on <Exit> to remove the Instrument Status window.
4. Click on <Quit> to remove the Diagnostics window and display the Main window.

SECTION ELEVEN

TROUBLESHOOTING

11.1 Power Up Diagnostics

Each time the instrument is powered up, a series of diagnostic tests is performed automatically to ensure proper operation of major system components. As the tests are performed, a window with "Executing Power Up Diagnostics" is displayed. When all tests are complete, the Power Up Diagnostics window is displayed.

Each of the diagnostic tests is listed on the Power Up Diagnostics window. Following the test name is "Passed", "Failed" or "Not Installed". If any of the tests fail, power down the instrument, then power it up again. If the failure persists, the instrument may be partially operational, as described in the following table.

The "Visible Lamp" and "Light Path" failures can be corrected by the user. (If the problem persists, contact the local Beckman service office.) If any other test fails, contact the local Beckman service office.

Failed Test	Explanation
CPU PROM RAM Controller RAM Video Controller Video RAM Video Palette	The instrument cannot be used.
RS232 Ports 1 and 2	RS-232 ports 1 (mouse) and/or 2 cannot be used.
EE PROM	Configuration parameters and the wavelength calibration will not be stored when the instrument is powered down. Calibrate the wavelength each time the instrument is powered up if this test fails.

1
1

Failed Test	Explanation
PROM Option Software Option	Software options are not available.
RAM Option	The expanded memory option in the A-drive is not available.
RAM Battery Backup	The files stored in the A-drive will be lost when the power is turned off.
Programmability	Programmability is not available.
RS232 Ports 3 and 4	RS-232 ports 3 and/or 4 cannot be used.
Keyboard Processor	The keyboard cannot be used.
Detector Gain	Readings cannot be taken. The instrument can be used for other functions.
Visible Lamp	Replace the visible source. Directions are provided in section 12.3 of this manual.
Light Path	Something is blocking the light path through the sample compartment. Remove the sampling accessory and power up the instrument again.
Filter Lamp Selector	Readings cannot be taken. The instrument can be used for other functions.
Wavelength Drive	The wavelength may not be accurate. Use the instrument only if the accuracy of the readings can be verified. Contact Beckman service.
System Clock	The date and time display may not be accurate. Also, time intervals may not be timed correctly.

11.2 Operational Failures

There are three failures that can occur during instrument operation. These are displayed under the Permanent Menu Bar on the left-hand side. The failure is displayed until the condition is corrected.

Message	Recommended Action
VIS LAMP Failure	Replace the visible source. Directions are provided in section 12.3 of this manual.
UV LAMP Failure	Replace the UV source. Directions are provided in section 12.2 of this manual.
OVER TEMPERA- TURE SHUTDOWN	Contact the local Beckman service office. Do not continue using the instrument.

11.3 Operational Messages

The following messages can occur while operating the instrument and are displayed in an error window. In most cases, these errors do not indicate an instrument malfunction, but a situation where an action was initiated that the instrument cannot perform.

If the instrument can continue operating with the error condition, the window is removed after 3 seconds. If the instrument requires operator action to continue, the user must click to remove the window.

Message	Explanation/Recommended Action
Bad file name	The input file name is invalid. Check the characters input for both the directory and file name.
Cannot execute custom application	The method directory where the application was originally created is full. Delete files from the method directory to make more room.
Could not write to disk	Check the disk. It is not installed, is full, or is write protected.
Cannot write to temporary file _____	Data cannot be stored using a default file name. Input a different file name.
Changes not saved, File protected	The method file is protected. To store the changes, protection must be removed.
Delete failed	The file to be deleted could not be found; verify the disk is installed in the drive. Protected method files cannot be deleted.
Disk controller fault	Check the disk drive. It is not installed or no disk is in the drive.
Drive error	Check the disk drive. It is not installed or no disk is in the drive.
Drive timeout	There is no disk in the drive. Insert a disk in the drive.

Message	Explanation/Recommended Action
End of file	The file has an error in it. No data exists at the location specified by the row and column.
Exceeded number of readings	The maximum number of readings that can be stored in a file has been reached. Click on <SaveClear> to either store or delete the data. Then data collection can resume.
Exceeded number of notes (4)	The number of annotations that can be made on a graph is limited to 4.
Failed to save method file	There is not enough room on the disk to store the file. Insert another disk or delete file(s) to make room on the current disk.
File already exists	The user asked for data to be stored in a file that already exists. If the data are stored, the existing data will be overwritten. Or, input a different file name.
File is protected	If the method file is protected, the file cannot be deleted and changes to the file cannot be stored. Remove protection to change the file.
File not found	Either the source or destination file was not found. If disk was removed or exchanged after the directory was displayed, replace the original disk.
File not saved	The method/data were not stored. Check the disk. There is no space on the disk, a faulty disk, or the file name is invalid.
File protection was not changed	An unacceptable user name or password was input. Input the correct user name or password.

Message	Explanation/Recommended Action
File Read Failed	The data were not retrieved. Check the disk. There is no disk, no space on the disk, a faulty disk, or the file was not closed properly.
File Write Failed	The data were not stored. Check the disk. There is no disk, no space on the disk, a faulty disk, or the file is already closed.
Format failed	The disk was not formatted. Check the disk. It may be faulty or the density may be wrong.
Illegal file name	A default file name cannot be used for a data file. Reserved file names include: "WORK_RES", "WORK_STD", "WORK", "W1_RES", and "SCAN". Use another file name.
Incompatible file type	The file cannot be read because it was copied into a directory other than where it was created.
Invalid directory	The file cannot be moved/copied into the selected directory.
Invalid disk	Check the disk. It is not formatted or is faulty.
Memory allocation failed	On entry to an analysis mode, the system was unable to find enough memory to run. Reset the instrument. This can result from a very long program executing an analysis mode.
Method directory full	A maximum of 100 method files can be stored in a directory. Delete existing files to make room for additional files.

Message	Explanation/Recommended Action
Move failed	There was not enough room to store the file in the new location. Delete file(s) to make more space.
No disk controller	The disk drive is not installed.
Out of disk space	The disk is full. Insert a new formatted disk.
OVER TEMPERATURE SHUTDOWN	Contact the local Beckman service office. Do not continue using the instrument.
Printer is not On Line	Press the "ON LINE" button on the printer, so the indicator light is illuminated.
Program area full	A program can have a maximum of 1000 steps. Edit the program so that it has less steps.
Read limit reached, click on SaveClear	The maximum number of readings has been reached. Click on <SaveClear> to either store or delete the data. Then data collection can resume.
Rename failed	The file was not renamed because it could not be found or an invalid file name was input. Check the file names.
Reserved file name	A reserved file name cannot be used to store data. Reserved file names include: "WORK_RES", "WORK_STD", "WI_RES", "WORK", and "SCAN". Change the file name.
Source and Destination files are the same	A file cannot be moved, copied or renamed if the source and destination files are the same. Change either of the file names.
Too many files selected for renaming	More than one file name was clicked on for renaming. Only one file can be renamed at a time.

Message	Explanation/Recommended Action
Transport failure	The transport cannot move to the expected location. Verify that the number of cells input in the analysis parameters is not greater than the number of cells in the transport configuration. Verify that nothing is blocking the movement of the transport, then "HOME" the transport using the Device Control window. If the failure persists, contact Beckman service.
Transport not installed	The Auto Cell Holder cannot be used because the transport is not installed. If it is physically in the sample compartment, verify that the cable is connected to the back of the instrument.
Unable to convert file to ASCII format	Method files are already ASCII files and therefore do not need to be converted to ASCII files.
Unable to convert file to Lotus format	Method files cannot be converted to Lotus.
Unable to open destination file	Verify the file name is valid and that the disk is installed.
Unable to open source file	Verify the file name is valid and that the disk is installed.
UV LAMP Failure	Replace the visible source. Directions are provided in section 12.3 of this manual.
VIS LAMP Failure	Replace the UV source. Directions are provided in section 12.2 of this manual.
Warning: Blank Needed	Place a cuvette of solvent in the cell holder and click on <<BLANK>>. Any reading taken without a blank is invalid.

Message**Explanation/Recommended Action**

Warning: Lamps Off

Turn on the source(s). Wait for the UV source to fire, then blank the instrument. Any reading taken without a source on is invalid.

Wrong file type

The file type is incorrect for the mode being used. The file was copied into an incompatible directory.

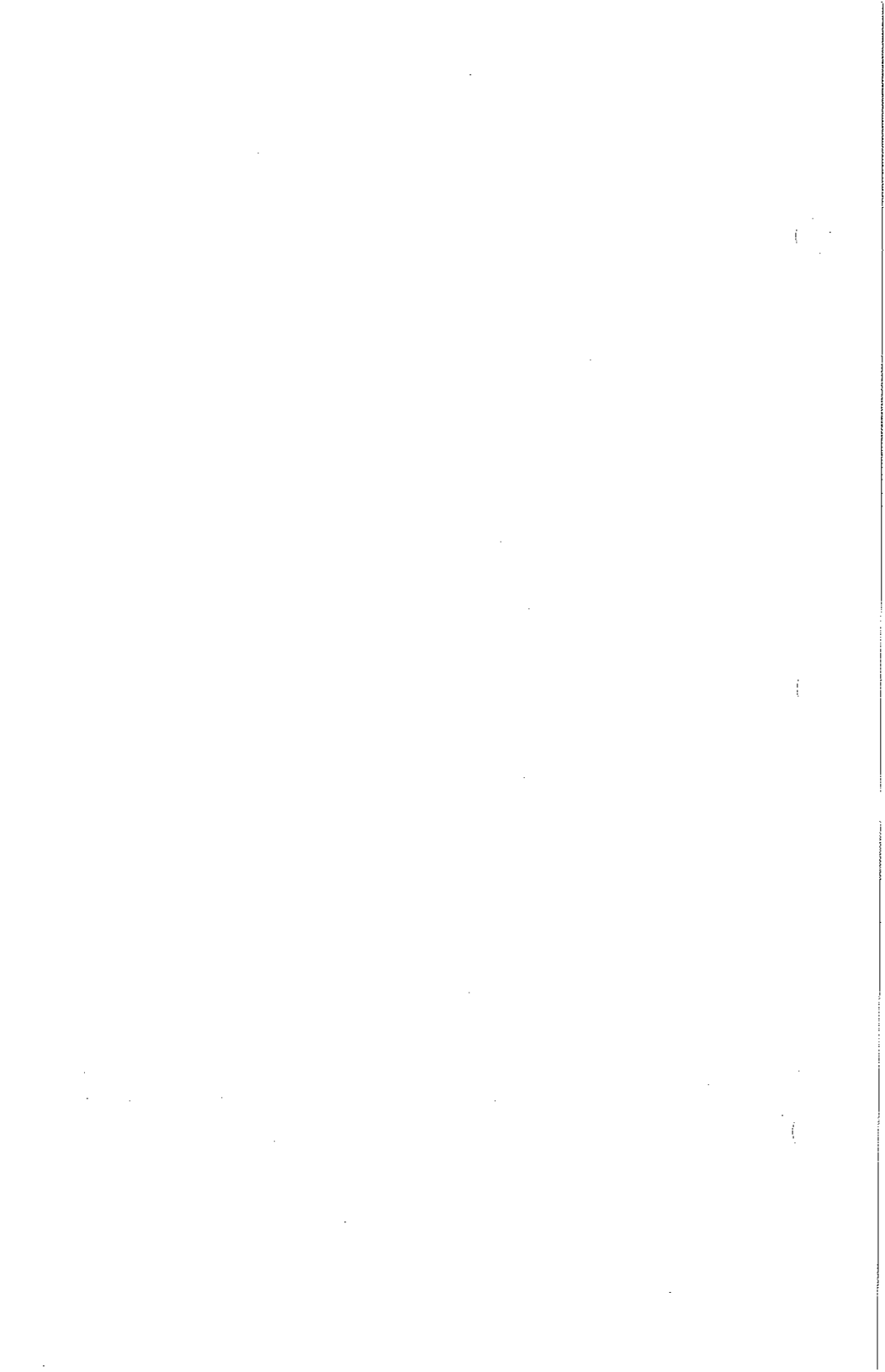

SECTION TWELVE

CORRECTIVE MAINTENANCE

NOTICE

Refer to the SAFETY NOTICE before following a procedure in this section. Refer all servicing for procedures not contained in this section to qualified Service personnel.

12.1 Fuse Replacement

The only user accessible fuses are the power fuses, located next to the receptacle where the power cord is plugged into the instrument. The instrument has one fuse if it is 100/120V; it has two fuses if it is 220/240V.

Parts required:

100/120V instrument - 3A slow blow fuse (UL/CSA), P/N 883908

220/240V instrument - 1.6A slow blow fuse (IEC), P/N 897176

Tools required: Small flatblade screwdriver

1. Turn the instrument around, so that the back can be accessed.
2. Unplug the power cord from the instrument.
3. Use the end of the screwdriver to pry the cover off of the fuse holder. See Figure 12-1.

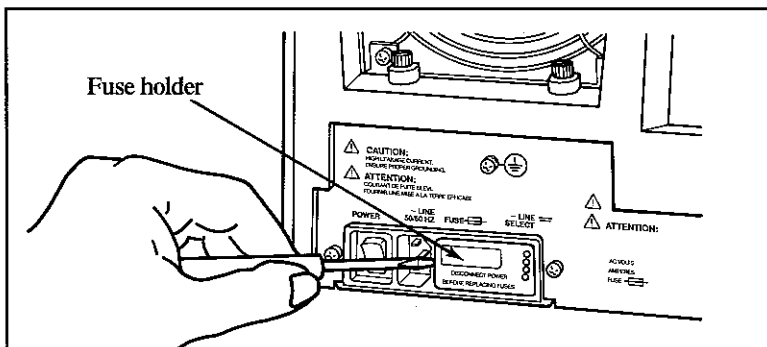

Figure 12-1.

- Note the orientation of the fuse(s) in the holder. Remove the fuse, then replace with the new fuse, oriented in the same position. See Figure 12-2. On 220/240V instruments, both of the fuses should be replaced, even though only one may look faulty.

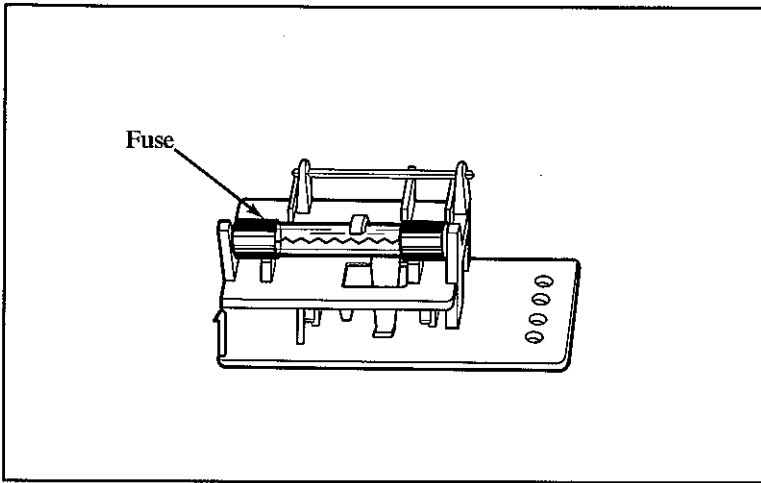

Figure 12-2.

⚠ WARNING

For continued protection against risk of fire, replace the fuse(s) only with the type and current rating specified above.

⚠ ATTENTION

Afin d'assurer une protection permanente contre les risques d'incendie, remplacer uniquement par un fusible de même type et valeur.

- Replace the fuse holder, and press to secure.
- Plug the power cord back into the instrument.
- Turn the instrument around so that it is facing forward.

12.2 UV Source Replacement

Parts required: UV source, P/N 514366

1. Unplug the instrument power cord. Allow the instrument to cool for 15 minutes.

⚠ CAUTION

To avoid risk of electrical shock, disconnect power to instrument before changing either source.

The UV lamp operates at a high temperature. To prevent burns, allow at least 15 minutes for the instrument and sources to cool before handling internal components.

The UV lamp generates UV light. Do not look directly at an operating lamp without wearing UV protective eye glasses.

⚠ ATTENTION

Risque de choc électrique. Débrancher l'appareil avant de changer de source.

2. Remove the display from the top of the instrument cover. Unscrew the thumb screw which secures the source cover. Open the source cover and remove it. See Figure 12-3.

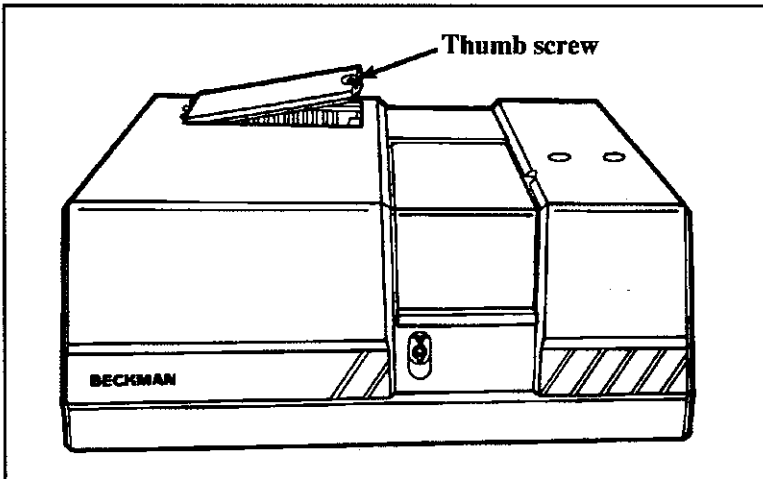

Figure 12-3.

3. To unplug the connector for the UV source, squeeze on the tabs on the sides of the connector, then pull up to release. See Figure 12-4.

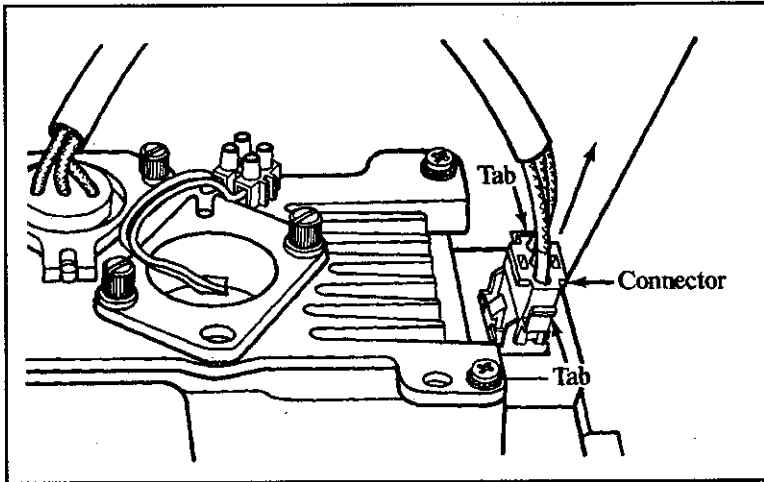

Figure 12-4.

4. Unscrew the two thumb screws which hold the UV source in position. See Figure 12-5.

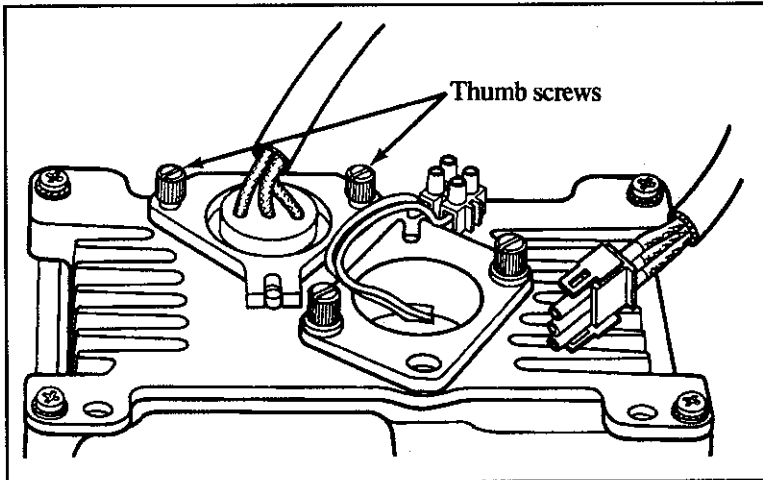

Figure 12-5.

5. Remove the source by lifting straight up. See Figure 12-6.

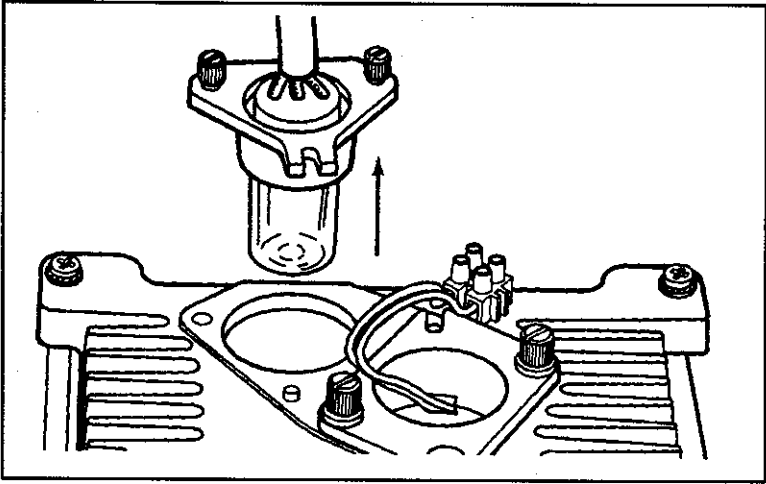

Figure 12-6.

6. Unpackage the new source, being careful not to touch the glass envelope on the source. Carefully push the new source straight down, until it is seated flat against the source housing. Secure by tightening the two thumb screws, shown in Figure 12-5. Plug in the connector, shown in Figure 12-4.

NOTICE

Do not touch the glass envelope on the new source. If it is touched, clean with alcohol.

7. Replace the source cover and secure by tightening the thumb screw. Reposition the display on the top of the instrument cover.
8. Plug in the instrument. When the diagnostic checks are complete, the Power Up Diagnostics window is displayed. Click on **<Quit>** to display the Main window.

9. Click on **<Diagnostics>** to display the Diagnostics window. Click on **<ResetHrs>**. The following window is displayed.

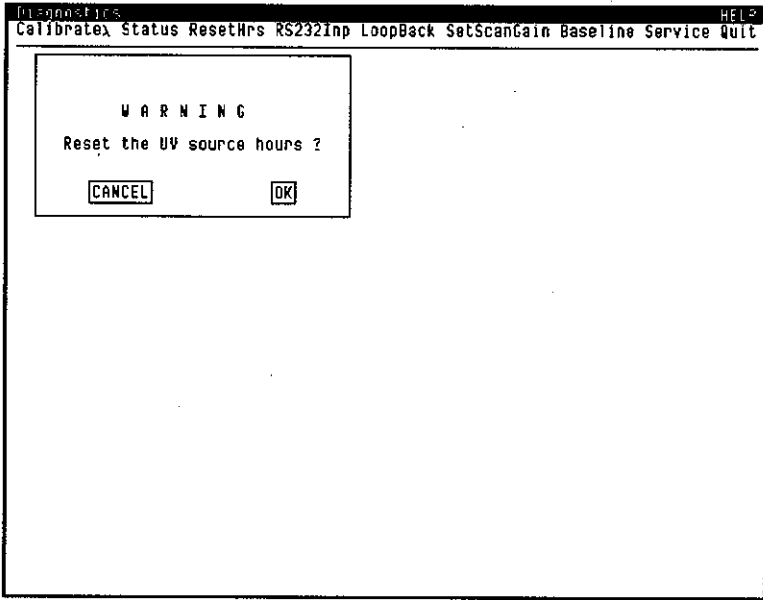

10. Click on **[OK]** to reset the UV source hours to 0, then click on **<Quit>** to return to the Main window.

12.3 Visible Source Replacement

Part I. Replacing the Source

Parts required: Visible source, P/N 945672

1. Unplug the instrument power cord. Allow the instrument to cool for 15 minutes.

⚠ CAUTION

To avoid risk of electrical shock, disconnect power to instrument before changing either source.

The visible lamp operates at a high temperature. To prevent burns, allow at least 15 minutes for the instrument and sources to cool before handling internal components.

⚠ ATTENTION

Risque de choc électrique. Débrancher l'appareil avant de changer de source.

2. Remove the display from the top of the instrument cover. Unscrew the thumb screw which secures the source cover. Open the source cover and remove it. See Figure 12-7.

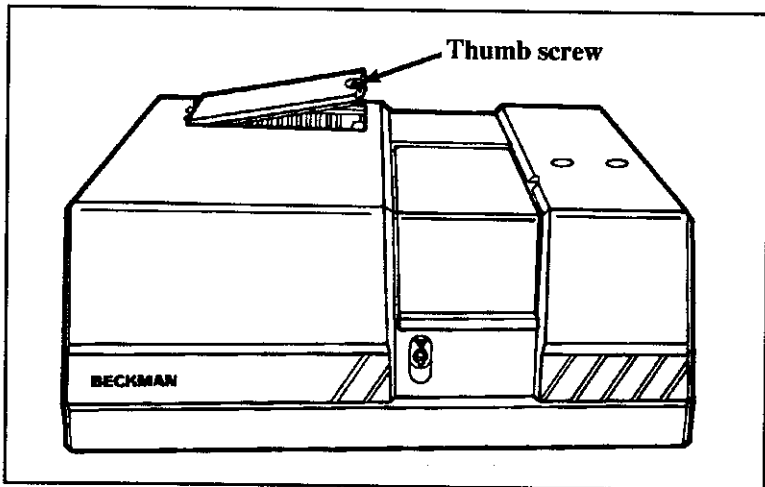

Figure 12-7.

3. Unscrew the two thumb screws which hold the visible source mounting bracket in position. See Figure 12-8.

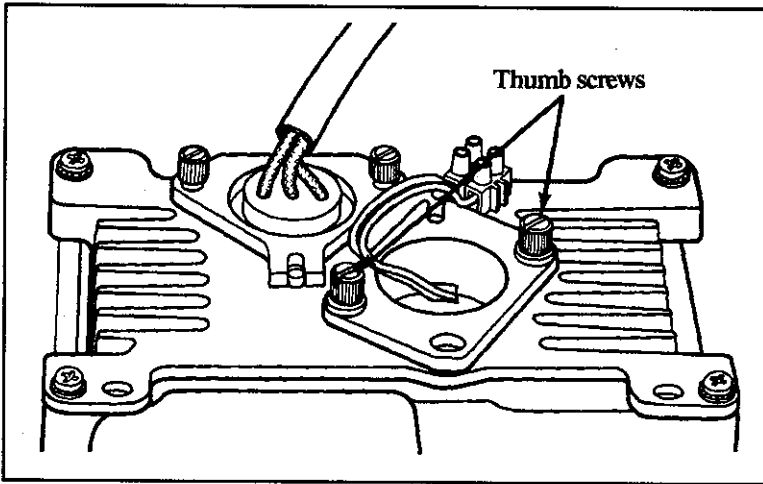

Figure 12-8.

4. Remove the source mounting bracket by lifting straight up. Rotate the source mounting bracket so that the visible source is accessible. See Figure 12-9.

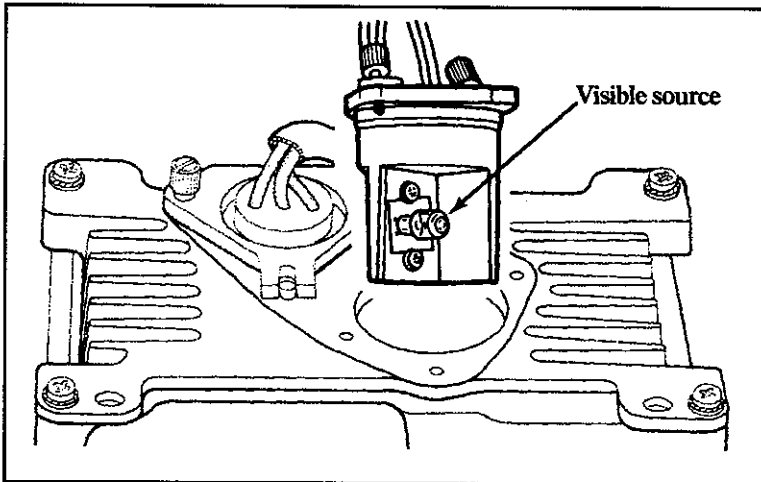

Figure 12-9.

- Carefully remove the old source by pulling straight out. Unpackage the new source, being careful not to touch the glass envelope on the source. Hold the source with a tissue or Kim-Wipe and insert it into the source mount in the same location as the old source. See Figure 12-10.

NOTICE

Do not touch the glass envelope on the new source. If it is touched, clean with alcohol.

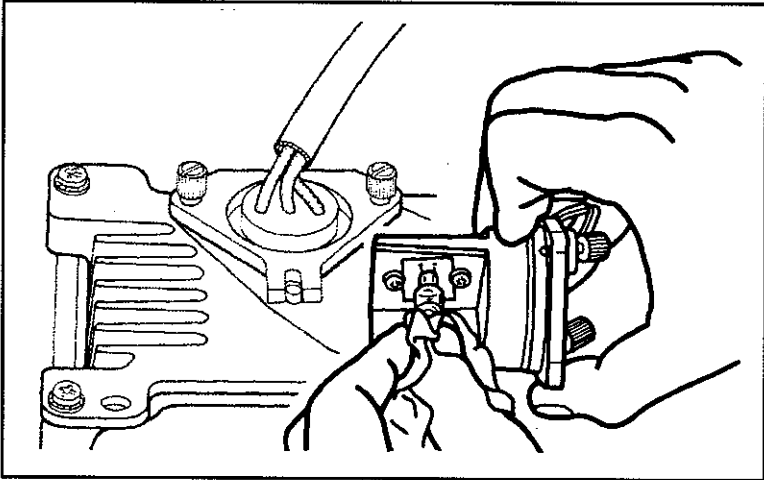

Figure 12-10.

- Replace the source mounting bracket and tighten the two thumb screws. See Figure 12-8.

art II. Peaking the Source

Tool required: Peaking tool (Provided in the shipping kit.)

1. Plug in the instrument.
2. Click on <Exit> to remove the Power Up Diagnostics window from the display.
3. Click on <<VIS OFF>> to turn on the visible source.
4. Click on "FIXED WAVELENGTH" to display the Fixed Wavelength window.
5. Click on <Parameters>, located in the menu bar at the top, center of the Fixed Wavelength Window. The Parameters window, Figure 12-11, is displayed.

Fixed Wavelength				HELP
ReadSamples	Method	Parameters	Save/Clear	Print Quit
Results file: A:\WORK RES		Method name: A:\DEFAULT		↑
Read average time: 0.50		Read mode: [ZT]		→
		Sampling device: None		↓
Sample ID	λ	Factor	Fixed Wavelengths Parameters	
	500.0	1.000	ClearAll	Print Exit
	ZT	Result	Wavelength	Factor Units Use
		ng/ml		
1			500.0	1.000 ng/ml [Yes]
			250.0	1.000 ng/ml [NO]
			300.0	1.000 ng/ml [NO]
			350.0	1.000 ng/ml [NO]
			400.0	1.000 ng/ml [NO]
			450.0	1.000 ng/ml [NO]
			500.0	1.000 ng/ml [NO]
			550.0	1.000 ng/ml [NO]
			600.0	1.000 ng/ml [NO]
			650.0	1.000 ng/ml [NO]
			700.0	1.000 ng/ml [NO]
			750.0	1.000 ng/ml [NO]

Figure 12-11. Fixed Wavelength Window with Parameters Window

6. To select a wavelength of 500 nm:
 - a. Click on the first wavelength value in the table and input a wavelength of 500 nm.
 - b. In the "Use" column, set the selection for the first wavelength (500 nm) to [Yes]. Set the selection for all the other wavelengths to [No].
 - c. Click on <Exit> to remove the Parameters window.
7. Locate the "Read mode" parameter, near the top in the center of the window. Verify that [%T] is displayed. If [Abs] is displayed, click on it to display [%T].
8. Click on <ReadBlank> to blank the instrument. A reading of 100 %T is displayed with the status information in the Permanent Menu Bar.
9. Loosen slightly the two thumb screws that secure the visible source mounting bracket.
10. Insert the peaking tool into the adjustment hole, on the front corner of the source mounting bracket. See Figure 12-12.

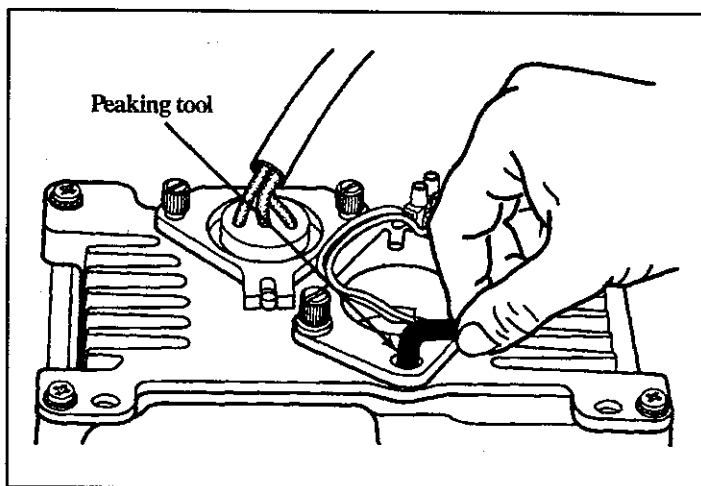

Figure 12-12.

11. Turn the peaking tool a small amount in the clockwise direction and observe the reading at the bottom of the display.
 - a. If the reading is higher than the initial reading, continue turning clockwise and taking readings until the maximum reading is obtained.
 - b. If the reading is lower than the initial reading, turn the tool counter-clockwise and take readings until the maximum reading is obtained.
 - c. If the reading exceeds 150%T, click on **<ReadBlank>** to reset the reading to 100%, then continue until the maximum reading is obtained.
12. Tighten the two thumb screws that secure the visible source mounting bracket. See Figure 12-8.
13. Replace the source cover and secure by tightening the thumb screw. Reposition the display on the top of the instrument cover.

SECTION THIRTEEN

TECHNICAL SPECIFICATIONS

13.1 Performance Specifications

Scan Speeds	120, 240, 600, 1200, 2400 nm/min
Data Collection Rate	20 samplings/second
Response Time	0.05 second
Wavelength Range	190 to 1100 nm
Wavelength Accuracy at 656.1 nm	± 0.2 nm
Full Range	± 0.5 nm
Wavelength Repeatability at 656.1 nm	± 0.1 nm
Full Range	± 0.2 nm
Spectral Bandwidth (from 200 to 680 nm)	≤ 1.8 nm
Photometric Readout	-0.300 to 3.000 A or 0.0 to 200.0 %T
Photometric Accuracy (at 1 A with NIST 930D solid filter at 546 nm)	± 0.005 A
RMS Noise (0A, average of 10 standard deviations of 10 readings at 0.05 sec intervals at 500 nm)	≤ 0.0002 A rms ^{1/} ≤ 0.0005 A rms

¹ Instruments with serial numbers 4319100 and higher.

Stray Light <math><0.05\%</math>
(measured using NaI at
220 nm per ASTM E387-84)

Stability <math><0.003 \text{ A}</math>
(0A, constant ambient conditions,
measured for 1 hour at 340 nm)

Baseline Flatness $\pm 0.001 \text{ A rms}^2/$
$\pm 0.003 \text{ A rms}$
(from 200 to 900 nm, at 0 A)

13.2 Physical and Environmental Specifications

Width 69 cm (27 inches)

Height 58 cm (23 inches)

Depth 53 cm (21 inches)

Weight 33 kg (73 lbs)

Line Voltage 100/120V$\pm 10\%$ or
220/240V$\pm 10\%$

Frequency 50/60 Hz

Power 200 watts typical

Ambient Temperature
Operating Range +15 to 40°C (59 to 104°F)

Humidity <math><85\%</math> maximum relative humidity,
not to exceed 32.5°C WBT

² Instruments with serial numbers 4319100 and higher.

13.3 Storage and Transport

The DU Series 600 Spectrophotometer should be stored with the power off when not in use for several days or more. The sample compartment cover should be closed. It is necessary for the instrument to be placed in the upright position on a flat surface, or the optics could become misaligned.

The instrument should be transported in the upright position, with care taken not to jolt, bounce or shake the instrument in transport. Pack the instrument in the original shipping container for transport, if available.

13.4 Sample Compartment Configuration

The diagram in Figure 13-1 shows the location and size of the beam in the sample compartment. Notice that the beam focus is near the right-hand side of the sample compartment. Sampling accessories, which are installed correctly, will position the sample at the beam focus.

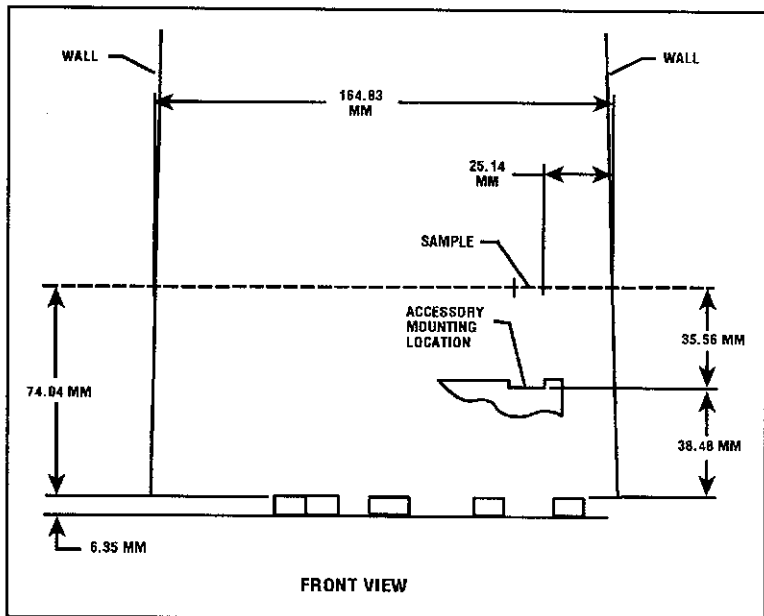
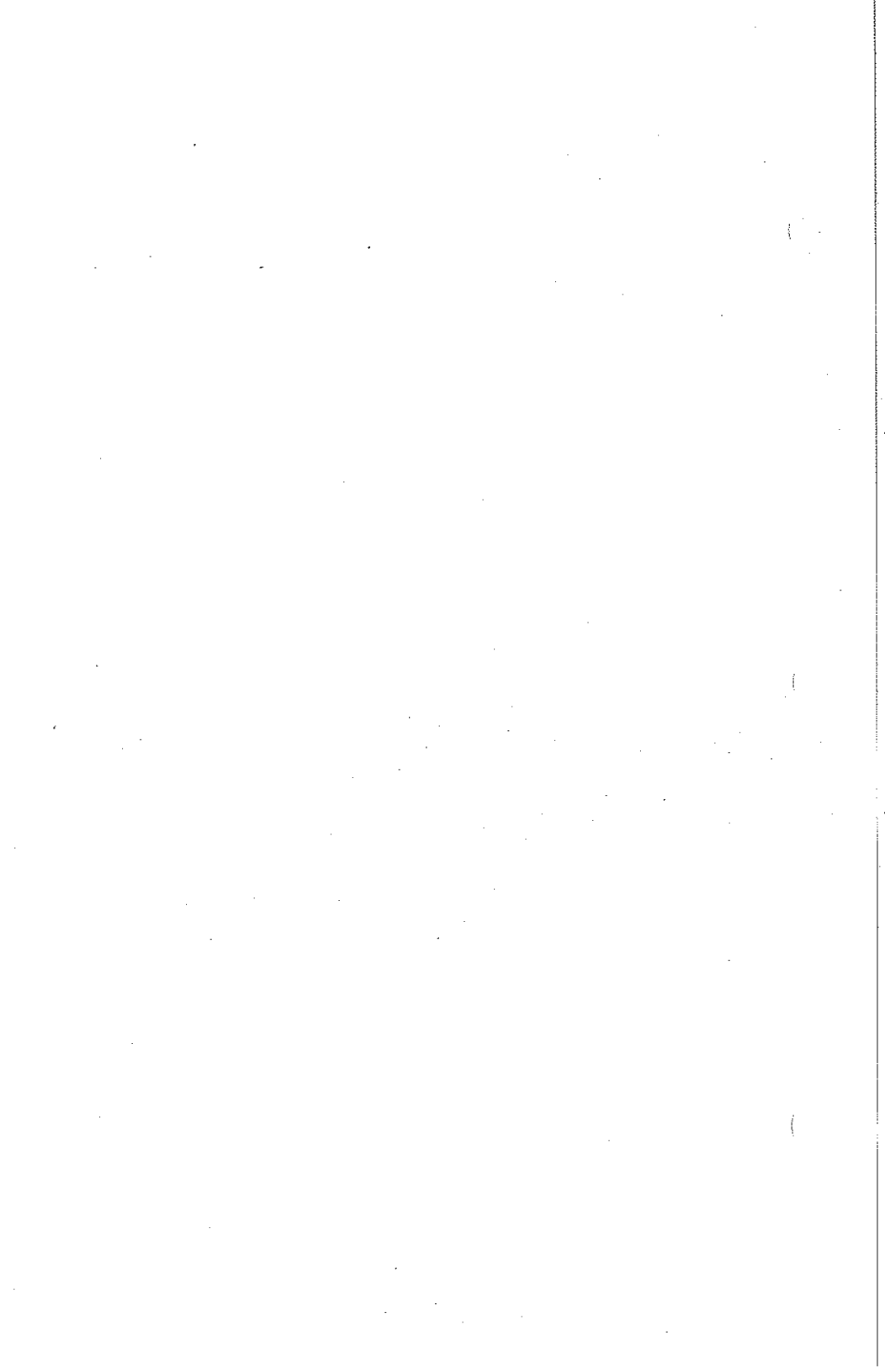

Figure 13-1. Sample Compartment Configuration



SECTION FOURTEEN

PARTS, SUPPLIES AND ACCESSORIES

Instruments

DU-640 Spectrophotometer, monochrome, 100/120V	517000
DU-640 Spectrophotometer, monochrome, 220/240V	517004
DU-640 Spectrophotometer, color, 100/120V	517002
DU-640 Spectrophotometer, color, 220/240V	517006
DU-650 Spectrophotometer, monochrome, 100/120V	517001
DU-650 Spectrophotometer, monochrome, 220/240V	517005
DU-650 Spectrophotometer, color, 100/120V	517003
DU-650 Spectrophotometer, color, 220/240V	517007

System Accessories

Printer Options

Dot Matrix Printer	523400
X-Y Plotter, 115V	523413
X-Y Plotter, 230V	523414

System Options

Keyboard	514666
Bar Code Accessory	514243
3½" Disk Drive, Controller Board and Cable	514244
1 MEG RAM	514252
Software Option Board	517035

Software Options

Protein Assay	517025
Nucleic Acid Analysis	517026
Fraction Read/Plot	517027
Performance Validation	517029
Single Component Analysis	517030
Multicomponent Analysis	517031
Enzyme Mechanism	517032
Enzyme Activity	517033
Gel Scan	517034

Sampling Accessories

Accessory Option Board	517036
Sample Holder Mount Options	
Stationary Mount	517023
Transport	514241
Sipper Options	
Sipper Accessory	514242
Unheated Flowcell Accessory	514253
Adjustable Cell Holder	594439
Micro Sipper Accessory	514256
Batch Sampler Options	
Batch Sampler, 117V	523417
Batch Sampler, 234V	523418
Gilson Interface Kit	514344
Auto 6 Cell Holder Options	
Unheated	523430
Water-regulated	523415
Peltier	523409
Peltier Temperature Controller	
115V	523422
230V	523423
Cell Holders for 50 μ L Microcells	
Micro-Auto 1	523382
Micro-Auto 6	523386
Cell Holder for 100 μ L Multi-Microcell	
Micro-Auto 12	514254
Cell Holder for 5 μ L Ultra-Microcell	
Adjustable Cell Holder	594439
Rectangular Cell Holder, 1 to 5 cm	517037
Cylindrical Cell Holder, 1 to 10 cm	517038

Gel Scan Accessories	
Gel Slits	596077
Tube Holder	523428
Film Holder	523429

Supplies

Dot Matrix Printer Supplies	
Fan Fold Paper	897516
Ribbon Cartridge	596281

X-Y Plotter Supplies	
Paper, 250 sheets	523274
Pens, set of 4 (red, green, blue, black)	523298
Cable (Male to female, RS-232 straight through, 3 meters.)	523198

Sipper Supplies	
Flowcell, 80 μ L	599925
Tubing Kit, Flowcell	514745
Micro Sipper Cell, 50 μ L	514758
Tubing Kit, Micro Sipper Cell	514282
Pump Tubing, Gray	651731
Pump Tubing, Red	651767
Waste Bottle	586656
Waste Tubing	598549

Microcells	
50 μ L Microcell, 1 each	523270
50 μ L Microcell, 2 each	523450
50 μ L Microcell, 4 each	523451
50 μ L Microcell, 6 each	523452
100 μ L Multi-Microcell, 1 each, 4 position	523255

Ultra-Microcells	
5 μ L Ultra-Microcell with 100 capillaries	514261
Replacement Capillaries, 100 each	514262

Trace-Klean™ Solution	
Concentrated, 946 mL	589784
Dilute, 473 mL	598190

Replacement Parts

Fuses

3A, slow blow, UL/CSA (for 110/120V instruments)	883908
1.6A, slow blow, IEC (for 220/240V instruments)	897176

UV Source	514366
-----------	--------

Visible Source	945672
----------------	--------

SECTION FIFTEEN

BECKMAN SALES AND SERVICE OFFICES

Beckman has local sales and service offices conveniently located throughout the world. For service, sales, or applications questions, contact the local Beckman office.

Australia

Beckman Instruments (Australia) Pty., Ltd.

24 College Street

Gladsville, N.S.W. 2111

Australia

Telephone: (61) (02) 816 5288

FAX (Sales): (02) 816 2614

FAX (Service): (02) 879 6669

ADELAIDE Office

Telephone: (08) 272 5844

FAX: (08) 272 8052

BRISBANE Office

Telephone: (07) 393 1622

FAX: (07) 891 0728

MELBOURNE Office

Telephone: (03) 544 3144

FAX: (03) 544 2951

PERTH Office

Telephone: (09) 328 2888

FAX: (09) 227 8074

Austria

Beckman Instruments GmbH

Inkustrasse 16

A-3400 Klosterneuburg

Austria

Telephone: (02243)856560

FAX: (02243)86460

Canada

Beckman Instruments (Canada) Inc.
1045 Tristar Drive
Mississauga, Ontario
Canada L5T 1W5
Telephone: (416)670-1234
FAX: (416)670-4563

France

Beckman Instruments France S. A.
92/94 Chemin des Bourdons
93220 Gagny
France
Telephone: (1) 43 01 70 00
FAX: (1) 43 81 16 80

Germany

Beckman Instruments GmbH
Frankfurter Ring 115
D-8000 Munich 40
Germany
Telephone: (089)38871
FAX: (089)3887-490

Hong Kong

Beckman Instrument (Hong Kong) Ltd.
15th Floor Unit B/D
Gee Chang Hong Centre
65 Wong Chuck Hang Road
Aberdeen, Hong Kong
Telephone: 814-7431
FAX: 873-0652

Italy

Beckman Analytical S.p.A.
Centro Direzionale Lambardo
Palazzo F/1
Via Roma 108
20060 Cassina de Pecchi
Milan, Italy
Telephone: (2)953921
FAX: (2)95392300

Japan

Beckman Instruments (Japan) Ltd.
6, Sanbancho
Chiyoda-ku
Tokyo 102, Japan
Telephone: (3)3221-5831
FAX: (3)3221-5888

Beckman Instruments (Japan) Ltd.
Shiono-Nissei Building
6-6, Doshomachi 2-chome
Chuo-ku
Osaka 541, Japan
Telephone: (6)203-2821
FAX: (6)203-2290

BSG Technical Center
Beckman Instruments (Japan) Ltd.
Yasuda No. 8 Building
3-8 Kaigan, 3-chome
Minato-ku
Tokyo 108, Japan
Telephone: (3)3452-4279
(3)3452-4115
FAX: (3)3221-6823

Mexico

Beckman Instruments de Mexico S.A. de C.V.
Chilpancingo 148
Colonia Roma Sur
06760 Mexico, D.F.
Telephone: (5)264-0667
FAX: (5)264-1998

Netherlands

Beckman Instruments Nederland B.V.
Nijverheidsweg 21
P.O. Box 47
3640AA-Mijdrecht, Netherlands
Telephone: (2979)85651
FAX: (2979)88082

Singapore

Beckman Instruments (Singapore) Pte Ltd.
1 Magazine Road
#02-06 Central Building
Singapore 0105
Republic of Singapore
Telephone: 534-2508
FAX: 533-0461

South Africa

Beckman Instruments Pty. Ltd.
P.O. Box 1949
Halfway House 1685
Johannesburgh
Republic of South Africa
Telephone: (11)805-2014
FAX: (11)805-4120

PINELANDS Office
Telephone: (21)531-7402

Spain

Beckman Instruments Espana S. A.
Avda. del Llano Castellano, 15
28034-Madrid
Spain
Telephone: 358 00 51
FAX: 358 04 26

Beckman Instruments Espana S. A.
Sabino de Arana 46-48
28028-Barcelona
Spain
Telephone: (93) 339 97 16
FAX: (93) 411 28 13

Sweden

Beckman Instruments AB
Archimedesvagen 2
Box 65
S-161 26 Bromma
Sweden
Telephone: (8)98-53-20
FAX: (8)98-74-34

Switzerland

Beckman Instruments International, S. A.
22 Rue Juste-Olivier
CH-1260 Nyon
Switzerland
Telephone: (022)631181
FAX: (022)621810

ZURICH Office

Telephone: (01)2721646
FAX: (01)2721614

BASEL Office

Telephone: (061)653939
FAX: (061)653969

Taiwan

Beckman Instruments
13 Floor, No. 249
Section 1, Tun Hwa South Road
Taipei, Taiwan
Telephone: (02)711-1166
FAX: (02)721-5274

United Kingdom

Beckman Instruments UK
Progress Road
Sands Industrial Estate
High Wycombe
Buckinghamshire, HP12 4JL
England
Telephone: (494)442233
FAX: (494)447558

United States

Beckman Instruments, Inc.
2500 Harbor Blvd.
Fullerton, CA 92634-3100
USA
Telephone: (800)742-2345 (Sales)
Telephone: (800)551-1150 (Service)
FAX: (714)773-7600
(800)643-4366

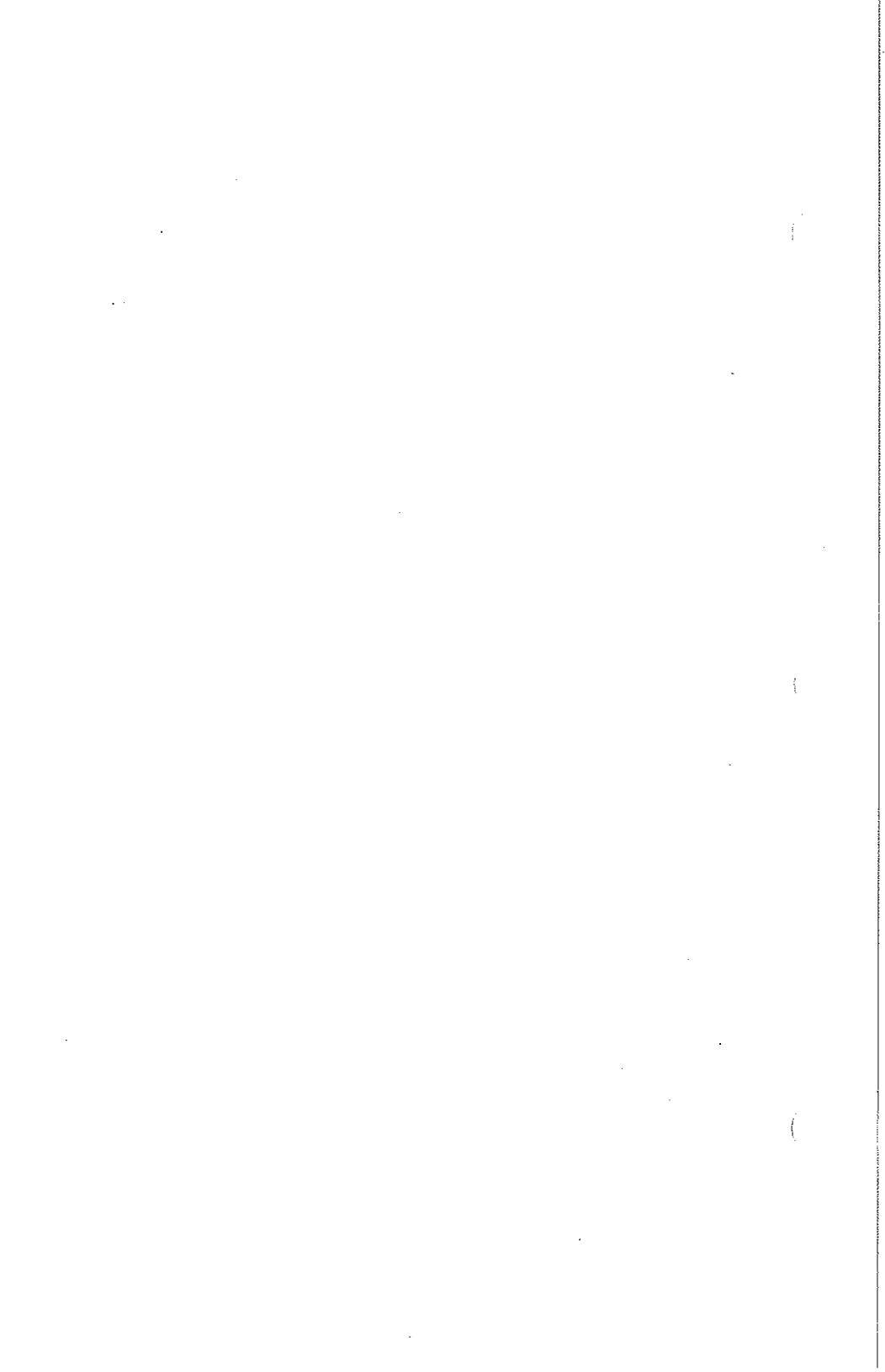

SECTION SIXTEEN

WARRANTY

Subject to the exceptions and upon the conditions stated below, Beckman warrants that this product shall be free from defects in workmanship and materials for one year after delivery of the products to the original Buyer by Beckman, and if any such product should prove to be defective within such one year period, Beckman agrees, at its option, either (i) to correct by repair or, at Beckman's election, by replacement with equivalent product any such defective product, provided that investigation and factory inspection discloses that such defect developed under normal and proper use, or (ii) to refund the purchase price. The exceptions and conditions mentioned above are as follows:

(a) components or accessories manufactured by Beckman which by their nature are not intended to and will not function for one year are warranted only to give reasonable service for a reasonable time; what constitutes reasonable time and reasonable service shall be determined solely by Beckman. A complete list of such components and accessories is maintained at the factory.

The following item is a consumable and has the following limited warranty:

514366 UV Source - 90 days from receipt

This limited warranty covers parts, only. Replacement instructions for this part are provided in section 12.2 of this manual. This limited warranty includes only the above named part.

(b) Beckman makes no warranty with respect to components or accessories not manufactured by it; in the event of defect in any such component or accessory Beckman will give reasonable assistance to Buyer in obtaining from the respective manufacturer whatever adjustment is authorized by the manufacturer's own warranty.

(c) any product claimed to be defective must, if required by Beckman, be returned to the factory, transportation charges prepaid, and will be returned to Buyer with transportation charges collect unless the product is found to be defective, in which case Beckman will pay all transportation charges.

(d) Beckman shall be released from all obligations under all warranties, either expressed or implied, if any product covered hereby is repaired or modified by persons other than its own authorized service personnel unless such repair by others is made with the written consent of Beckman.

IT IS EXPRESSLY AGREED THAT THE ABOVE WARRANTY SHALL BE IN LIEU OF ALL WARRANTIES OF FITNESS AND OF THE WARRANTY OF MERCHANTABILITY AND THAT BECKMAN SHALL HAVE NO LIABILITY FOR SPECIAL OR CONSEQUENTIAL DAMAGES OF ANY KIND OR FROM ANY CAUSE WHATSOEVER ARISING OUT OF THE MANUFACTURE, USE, SALE, HANDLING, REPAIR, MAINTENANCE OR REPLACEMENT OF THIS PRODUCT.

Representations and warranties made by any person, including dealers and representatives of Beckman, which are inconsistent or in conflict with the terms of this warranty, shall not be binding upon Beckman unless reduced to writing and approved by an expressly authorized officer of Beckman.

SECTION SEVENTEEN

INDEX

Subject	Page
+-* Parameters window	6-21
+-* Scans window	6-20
Absorbance reading	3-12
Accessories	14-1
Alphabetic keyboard	2-7
Alphanumeric keypad	2-7, 3-8, 3-15
Analysis modes	3-1
Analysis parameters	3-1
Analysis windows	3-2
Annotate	
in Kinetics/Time	7-13
in RediScan	4-7
in Wavelength Scan	6-16
Arrow	1-1, 3-1, 3-8, 3-9
ASCII directory	8-13
ASCII file	8-13
in Fixed Wavelength	5-13
in Kinetics/Time	7-23
in Wavelength Scan	6-31
Auto Cell Holder	3-10, 3-11
in Fixed Wavelength	5-5
in Kinetics/Time	7-10
in Wavelength Scan	6-13
Autoprint	6-8
Autosave	6-5, 6-8
Autoscale	6-8
in Kinetics/Time	7-13
in RediScan	4-7
in Wavelength Scan	6-16
Background correction in Kinetics/Time	7-2
Background scan	1-5 to 1-6

Subject	Page
Baseline	6-5
Batch sampler	2-1, 3-11
Bit image file	2-12
Blank	1-5, 3-5, 3-10
in Kinetics/Time	7-2
in RediRead mode	4-4
in Wavelength Scan	6-2
Blank subtraction in Kinetics/Time	7-3
Brightness control	2-5
Calibration	2-13
Cell number display	3-12
Cell position	3-11
Characters	3-15
Clear	3-6
Clicking on	1-1
Clock	2-8
Color	3-3, 3-15, 3-17
Color display	1-1, 2-7
Color palettes	2-7
Column labels	3-3
Commands	3-10
Communications Configuration window	9-2
Communications port	8-14, 8-16, 9-1, 9-2, 9-6, 9-9
start up instructions	9-4
Concentration	
in Fixed Wavelength	5-1
in Kinetics/Time	7-3
Configuration mode	2-6
Convert Files window	8-13
Copy File window	8-6
Corrected absorbance in Kinetics/Time	7-3
Create window	3-19
Cursor	3-6, 3-8
Custom Applications	3-21
Cuvette	1-5

Subject	Page
Data file	3-6, 3-23
in Fixed Wavelength	5-13
in Kinetics/Time	7-22
in Wavelength Scan	6-31
naming a	3-23
recalling a	3-24
Date	2-9, 3-12
Delete window	3-22, 8-9
Derivative	6-2, 6-17
Device Control window	3-11
Diagnostic tests	3-4
Directory	8-2, 8-3
Directory name	8-3
Disk drive	1-1, 3-23
Diskette symbol	3-9
Disk Status window	8-10
Display	2-4
DOS commands	8-1
Dot Matrix Printer	See Printer
Drive A	3-23, 8-1
Drive B	3-23, 8-1
Edit User Names and Passwords window	2-10
Enzyme Activity mode	1-2
Enzyme activity in Kinetics/Time	7-4
Enzyme Mechanism mode	1-2
Error message	11-4
External computer	8-14, 8-16, 9-1, 9-6
Failed	11-1
Fan	2-4
File names	3-3
File transfer	9-1
File Utilities mode	3-23, Section 8
File Utilities window	8-2
Fixed Wavelength Mode	Section 5
Fixed Wavelength window	5-2
Format Disk window	8-11
Function Selection window	6-17

Subject	Page
Fuses	14-4
replacement	12-1
Fraction Read/Plot	1-2
Gel Scan	1-3
General operating instructions	3-5
Getting Started	4-1
Gilson Sampler	
in Fixed Wavelength	5-6
in Wavelength Scan	6-13
Grid	2-7, 2-12
Help messages	3-2
Help windows	3-7
Hex value	9-7
Home position	3-11
Hour glass	3-9
Humidity	2-1
Installation	2-1
Instruments	14-1
Internal memory	3-23
Interval time	
in Kinetics/Time	7-6
in Wavelength Scan	6-7
ISCO Sampler	
in Fixed Wavelength	5-5
in Wavelength Scan	6-13
Keyboard	3-15
Kinetics/Time mode	Section 7
Location	2-1
Log of absorbance	6-3, 6-17
Loop Back Tests window	9-5
Lotus directory	8-13
Lotus file	8-13
in Fixed Wavelength	5-14
in Kinetics/Time	7-24
in Wavelength Scan	6-32
Lower case letters	3-8

Subject	Page
Main window	3-4, 4-2
Master access code	2-10
Match correction	3-10
in Kinetics/Time	7-2
Menu Bar	
window	3-3, 3-12
permanent	3-3
Method	3-5
creating a	3-18
deleting a	3-22
existing	3-19
protection	3-20
renaming a	3-21
stored	3-21
Method development	3-18
Method file	4-17
Method File Directory	3-18, 3-21
Method window	3-1, 3-18
Monochrome display	1-1, 2-7
Mouse	1-1, 2-6, 3-1, 3-8
Mouse button	3-8
Move Files window	8-8
Multicomponent Analysis	1-3
Nanometer position	3-12
Net absorbance	
in Kinetics/Time	7-2
in Wavelength Scan	6-4, 6-24
Noise	1-6
Not Installed	11-1
Note	3-19
Nucleic Acid mode	1-2
Numeric keypad	3-15
On line	2-5
Optical diagram	1-4
Output	9-1, 9-2, 9-8
in Fixed Wavelength	5-11
in Kinetics/Time	7-21
in Wavelength Scan	6-30
Overlay scans	6-8

Subject	Page
Palette	2-7
Parameters	
analysis	3-3, 3-5
bracketed options	3-17
input	3-15
limits	3-15
no changing	3-17
Parameters window	5-3
Part numbers	Section 14
Passed	11-1
Password	2-10, 2-11, 3-20
Peak pick	6-3, 6-18
Peaking tool	12-10
Pens	2-12
Performance Validation mode	1-3
Permanent menu bar	3-10
Point pick	6-3, 6-18
Power cord	2-4
Power up	2-4, 11-1
Power Up Diagnostics window	3-4, 4-1
Print	3-6
Print command	3-11, 3-14
Printer	3-11, 3-14
configuration	2-11
paper	2-5
ribbon	2-5
Program	2-8, 2-9
Program mode	1-3
Protection	2-10
Protection Configuration window	2-10
Protein Analysis mode	1-2
Quit command	3-6, 3-14, 3-23
Quit window	3-14
Rate calculation	7-3
Rates window	7-14
Raw Data window	7-16
Re-zero	1-5
Read average time	1-6

Subject	Page
Read mode	5-3
Read Samples command	3-6, 3-8, 3-13
Read Samples window	3-13, 7-9
Receive File window	8-14
RediRead mode	3-11, 4-4
RediScan mode	3-10, 4-6
Remote Control mode	9-1, 9-9
commands	9-11
Rename File window	8-5
Rename window	3-21
Repetitive scanning	6-2
Replacement parts	14-4
Result in Fixed Wavelength	5-1
Results File Directory window	3-14, 3-23, 3-24
Results file	3-23, 4-17, 7-4
RS-232 Input test	9-6
RS-232 test plug	9-5
RS232 Communications Input window	9-6
Sales offices	Section 15
Sample compartment size	13-3
Sample holders	14-2
Sampling accessories	1-3, 2-7
Save	3-19
Save Clear command	3-6, 3-13, 3-23
Save Clear window	3-13
Sample assignment in Kinetics/Time	7-8
Sample identification in Fixed Wavelength	5-5
Scan Directory window	6-15
Scan file	4-17, 6-5, 6-31
Scan gain	2-13
Scatter correction	6-4, 6-22
Scatter window	6-22
Screen saver delay	2-7
Screen keyboard image	2-7
Scrolling	3-3
Service offices	Section 15
Sensitivity	10-1
Serial number	10-2
Set Protection window	3-20

Subject	Page
Single Component Analysis mode	1-2
Sipper	
in Fixed Wavelength	5-5
in Kinetics/Time	7-10
in Wavelength Scan	6-10
Size	13-2
Smoothing	1-7
Software options	14-1
Software revision	10-2
Sources	4-3
Specifications	Section 13
Spectral addition/subtraction/multiplication	6-4, 6-20
Standard files	3-23
Status information	3-10, 10-2
Stop printing	3-6
Storage	13-2
Stored scans	6-15
Subtitle	2-11
Supplies	14-3
Transmit File window	8-16
Temperature control	2-1, 7-2
Temperature Controller	3-11, 3-12
Temperature display	3-12
TIFF file	2-12
Time	2-9, 3-12
Time drive	4-14
Time Drive mode	Section 7
Title	2-11
Trace	3-8, 6-3
in RediScan	4-7
in Kinetics/Time	7-13
in Wavelength Scan	6-15
Trace-Klean solution	14-3
Transmittance reading	3-12
Transportation	13-2
Transport accessory	3-12
Typewriter keyboard	2-7

Subject	Page
User ID	9-3
User Interface Configuration window	2-7, 2-11
User Name	2-11, 3-20
Utility requirements	2-2
UV WAIT	3-10
UV source replacement	3-10, 10-1, 10-2, 14-4 12-3
Valley pick	6-3, 6-18
VIEW	3-16
Virtual Disk A	8-11
Visible source peaking replacement	3-10, 10-1, 14-4 12-10 12-7
Wake up	2-9
Warranty information	Section 16
Wavelength calibration	2-13
Wavelength range	1-1
Wavelength Scan Mode	Section 6
Weight	13-2
Window	2-6, 3-2
Window Name	3-2
WORK_00X	6-5
X-Y Plotter	2-7, 3-11, 3-14, 9-2
Xon/Xoff Flow Control	9-3
Zoom	
in Kinetics/Time	7-13
in Wavelength Scan	6-15

