



Bruker **AXS**



D8 ADVANCE

● Diffraction Solutions

think forward

XRD

D8 ADVANCE
Highlights at
a glance

Design:
DAVINCI.DESIGN™ with
DAVINCI.MODE™
DAVINCI.SNAP-LOCK™
DIFFRAC.DAVINCI™

X-ray source:
TWIST-TUBE™

Detectors:
LYNXEYE™
VANTEC-1™
SOL-XE™

Optics:
TWIN™, primary
TWIN™, secondary

Best-Data Guarantee™ :
Best-Alignment Guarantee™
Best-Detector Guarantee™



D8 ADVANCE – designed for the next era in X-ray diffraction

The development of a new high tech product is judged by some very formidable standards. However, these standards become even more exacting when the product being developed is the successor to the most successful diffractometer in the world, boasting four thousand installations in ten years.

Hence it was a very big challenge to develop our new generation of diffractometers. The objective was to surpass our previous products and to live up to our role as the top supplier of X-ray systems for all applications.

We proudly present: the new D8 ADVANCE.

Our new D8 ADVANCE leaves nothing to be desired. It is completely reliable and convenient to operate, ergonomic and flexible. All these features are combined to form a system that guarantees superior quality results, the shortest possible measurement time and the highest analytical performance.

Get acquainted with our new D8 ADVANCE!



Smart screen key display



VANTEC-1 1-D detector



TWIST-TUBE



Compact Eulerian cradle



DAVINCI.SNAP-LOCK



Compact XYZ stage



SUPER SPEED



LYNXEYE 1-D detector



TWIN optics



LED shutter display



Fixed slits and filters



Motorized slit with Auto-Absorber



Axial Sollers



LED cabinet illumination



Fixed slit assembly



SOL-XE energy-dispersive detector





D8 ADVANCE – understanding the sample behind the signal



Pharmaceuticals



Pressed powder



Suspension



Loose powder



Fibers

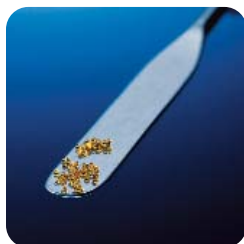

Small sample amounts



Inclusion



Capillary



Filters



Machined items



Bulk sample



Coatings and films

X-ray diffraction (XRD) is the ideal, non-destructive analytical method for examining all types of samples!

XRD enables crystalline phases to be identified, quantified, and their atomic structure determined – all with very little sample preparation. This prevents the risk of destroying the phases and/or modifying the characteristics of the sample.

In reality, a sample with a complex composition is a daunting challenge for many other methods – but not so for XRD. With XRD, every detail in the diffractogram is meaningful and ultimately enables the full characterization of a sample.

A diffractogram consists of peak positions, intensities and shapes, which are characteristic of a specific sample. Using this data, one can deduce the properties of the sample and obtain information that includes:

- Phase abundance
- Phase amounts
- Textures
- Residual stress
- Crystal structure
- Microstructure

The D8 ADVANCE is always supplied together with our DIFFRAC.SUITE. This latest and most comprehensive software package opens all analytical doors for you. Thanks to DIFFRAC.SUITE, you are in a position to meet any task from the very beginning, and achieve the desired results. It is unparalleled in terms of speed, simplicity and reliability.

The key to complete characterization of your sample: DIFFRAC.SUITE!

3-D microstructure of polycrystalline material

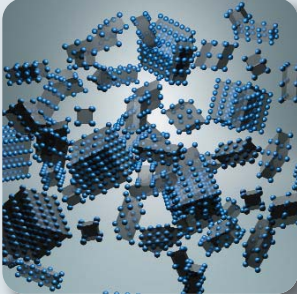

Randomly oriented crystallites

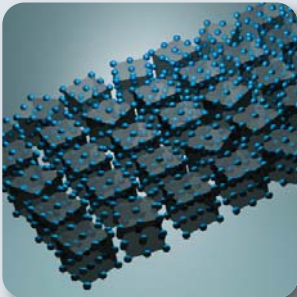

Crystallites arranged with preferred orientation

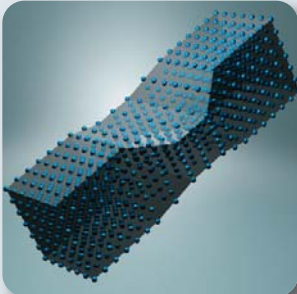

Shaped or machined sample



Micro-amount of crystallites

Typical diffraction pattern

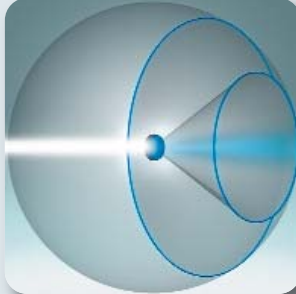

Uniform diffraction signal along Debye rings

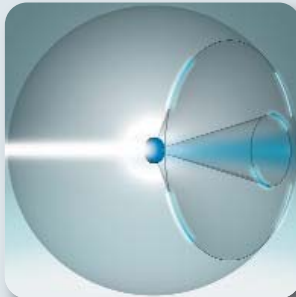

Non-uniform diffraction signal along Debye rings

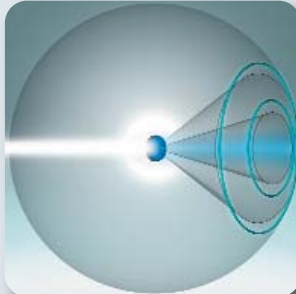

Debye rings deformed to ellipses

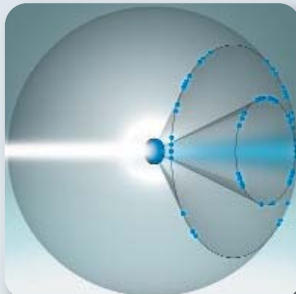

Individual diffraction spots along Debye rings

3-D diffraction pattern – the fingerprint

X-ray diffraction on a polycrystalline material results in a unique pattern. The pattern is a result of the interference of waves, which are diffracted by regular arrangements present in the crystallites. The dimensions of those so-called lattice spacings are similar to the wavelength of the X-rays. Bragg's law links the direction of the interference, the wavelength, and the dimension of

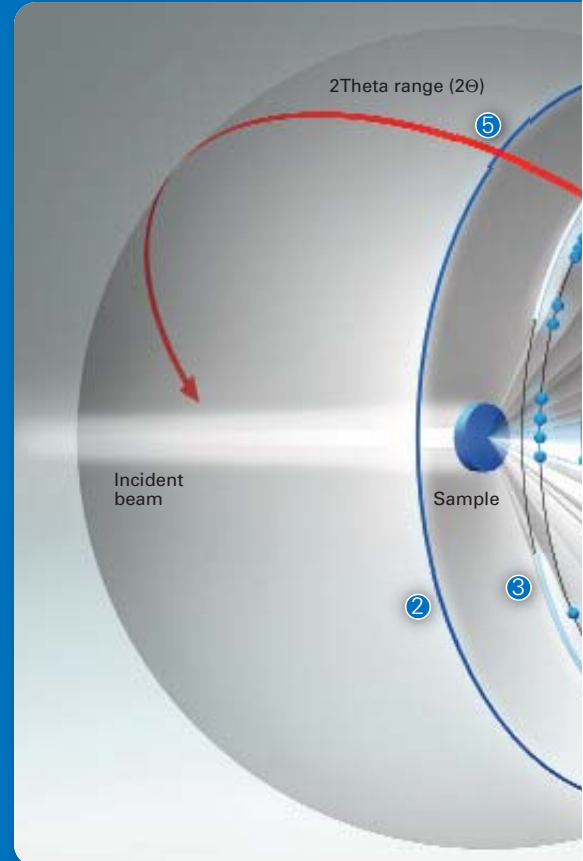

- ① The sample placed in the center of the sphere is illuminated by an X-ray beam. The forward direction of the beam defines the diffraction angle $2(\theta) = 0^\circ$.
- ② The crystallites in the sample diffract X-ray photons forming cones with specific opening angles. The angles are defined by the lattice spacings in the crystallites and the photon energy or rather wavelength. The intersection of the cones with the sphere are the so-called Debye rings.
- ③ The intensity distribution along the Debye rings reflects the microstructure of the sample. In the case of a sample showing

Print of the sample

the arrangement into one equation:

$$d = \frac{n \cdot \lambda}{2 \cdot \sin \theta}$$

"d" is the lattice spacing to be determined

"n · λ" is the multiple integer of the X-ray wavelength Lambda

"θ, Theta" is the direction angle of the interference

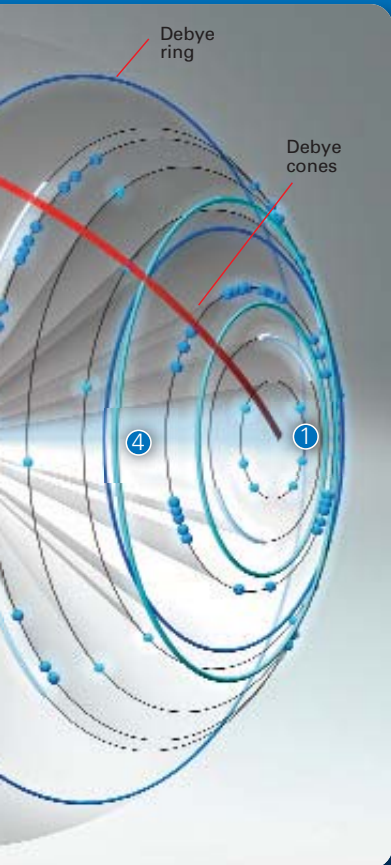

preferred orientation, the intensity is non-uniform, however it exhibits symmetries.

④ Diffraction does not change the wavelength. Consequently, the reason for a measured deformation of the Debye rings is a direction-related lattice spacing change which is caused by deformation of the crystallites.

⑤ Powder diffraction data are recorded by scanning a detector along an arc. If a Debye ring is crossed, a discrete diffraction peak appears in the scan. To record the diffraction intensities along a Debye ring, the sample needs to be rotated additionally around its surface normal.

Measurement results



Qualitative phase analysis

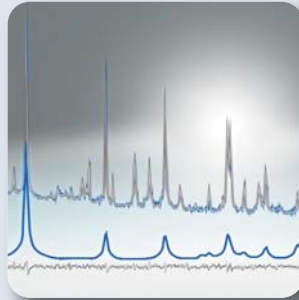

Quantitative phase analysis



Texture analysis

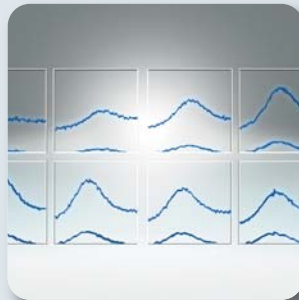

Stress analysis

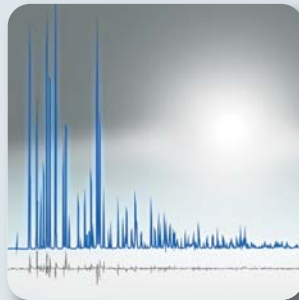

Crystal structure analysis

Sample properties

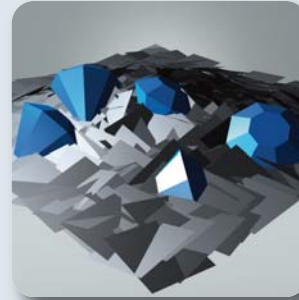

Phase identification

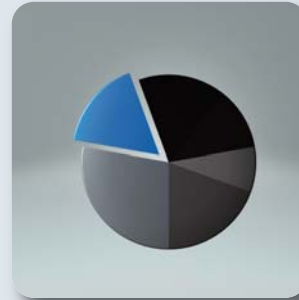

Phase quantification

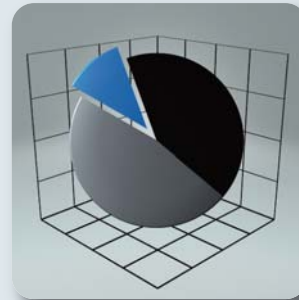

Orientation quantification

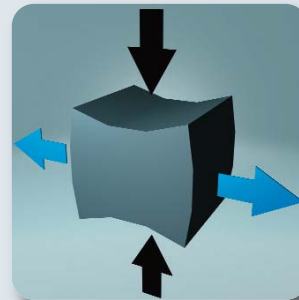

Residual stress

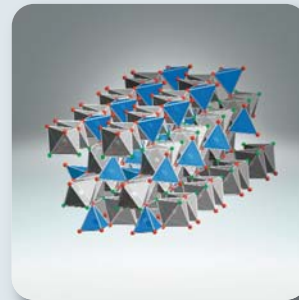

Structural information

Crystalline phase identification

- phase composition
- amorphous content
- polymorphism
- phase transition

Crystalline phase quantification

- composition
- % crystallinity
- polymorph quantification

Texture analysis

- preferred orientation
- pole figures, ODFs
- texture components
- orientation quantification

Residual stress

- strain
- deformation
- compressibility
- stress tensor
- hardness

Structural analysis

- lattice parameters
- crystalline structure
- symmetry
- coordination



DIFFRAC.EVA:
Phase identification

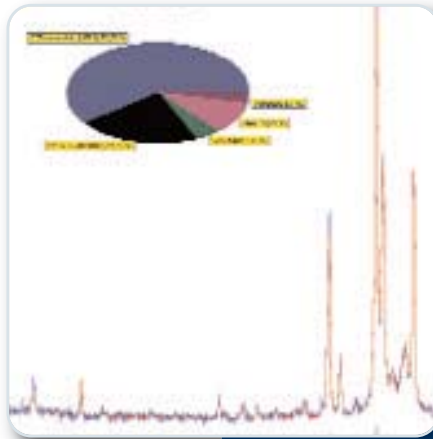

DIFFRAC.TOPAS:
Phase quantification

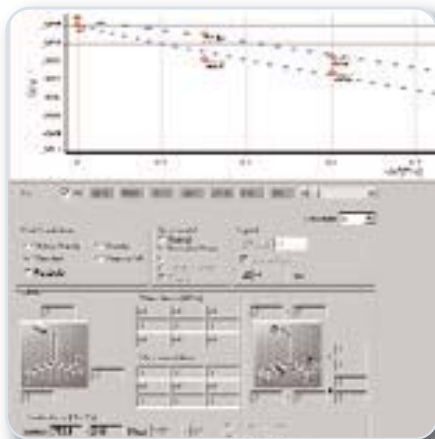

DIFFRAC.LEPTOS:
Residual stress analysis

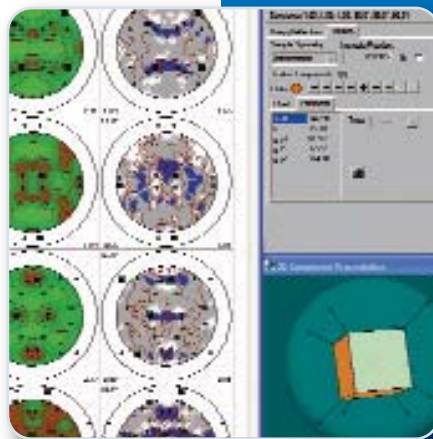

DIFFRAC.MULTEX:
Texture analysis

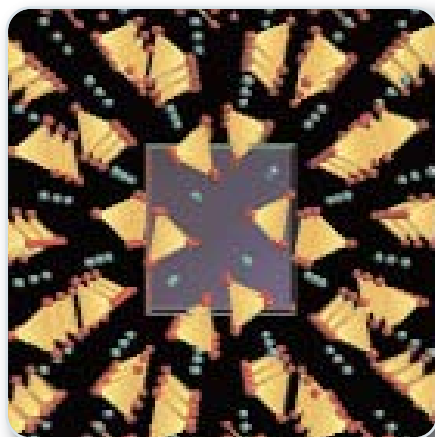

DIFFRAC.TOPAS:
Structure analysis

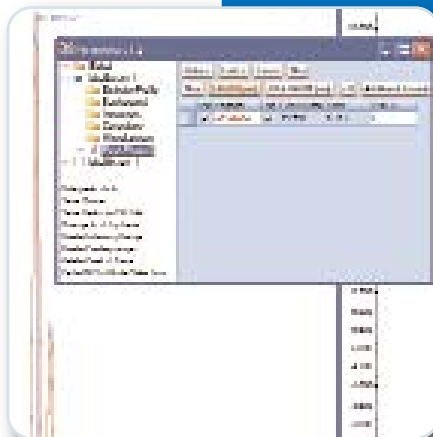

DIFFRAC.TOPAS:
Microstructure analysis

DIFFRAC.SUITE

DIFFRAC.MEASUREMENT CENTER with:

- DIFFRAC.LOG
- DIFFRAC.COMMANDER
- DIFFRAC.WIZARD
- DIFFRAC.DAVINCI
- DIFFRAC.TOOLS
- DIFFRAC.JOBLIST
- DIFFRAC.START JOBS
- DIFFRAC.CONFIGURATION
- DIFFRAC.D8 MANAGER

DIFFRAC.EVALUATION PACKAGE with:

- DIFFRAC.EVA
- DIFFRAC.TOPAS
- DIFFRAC.LEPTOS
- DIFFRAC.MULTEX
- DIFFRAC.POLYSNAP
- DIFFRAC.NANOFIT



DAVINCI.DESIGN – advanced ideas last forever

“Leonardo da Vinci is revered for his technological ingenuity and his extraordinary powers of invention. Leonardo developed a unique new attitude towards machines. He reasoned that by understanding how each separate machine part worked, he could modify them and combine them in different ways to improve existing machines. Leonardo set out to write the first systematic explanations of how machines work and how the elements of machines can be combined.”

So any qualified engineer is well-advised to take Leonardo's principles to heart. For over the centuries, they have lost none of their universal validity and relevance. It is clearly apparent which ideals our engineers adhered to when they developed our new D8 ADVANCE.

Like no other analytical method, X-ray diffraction is characterized by a wide variety of samples, applications and evaluation methods. This inevitably results in what are probably the most important demands on a state-of-the-art X-ray diffractometer: an absolutely open design and unrestricted, uncompromising modularity; coupled with maximum user-friendliness, operating convenience and safe handling. If, on top of this, the system relieves the user of many of his routine tasks and supports his activities, then an outstanding solution has been found for all X-ray diffraction tasks:

Our new D8 ADVANCE with DAVINCI.DESIGN!

121
4

Handwritten text in a cursive script, likely a preface or introduction to the drawing. The text is arranged in several lines across the top of the page, above the main illustration.

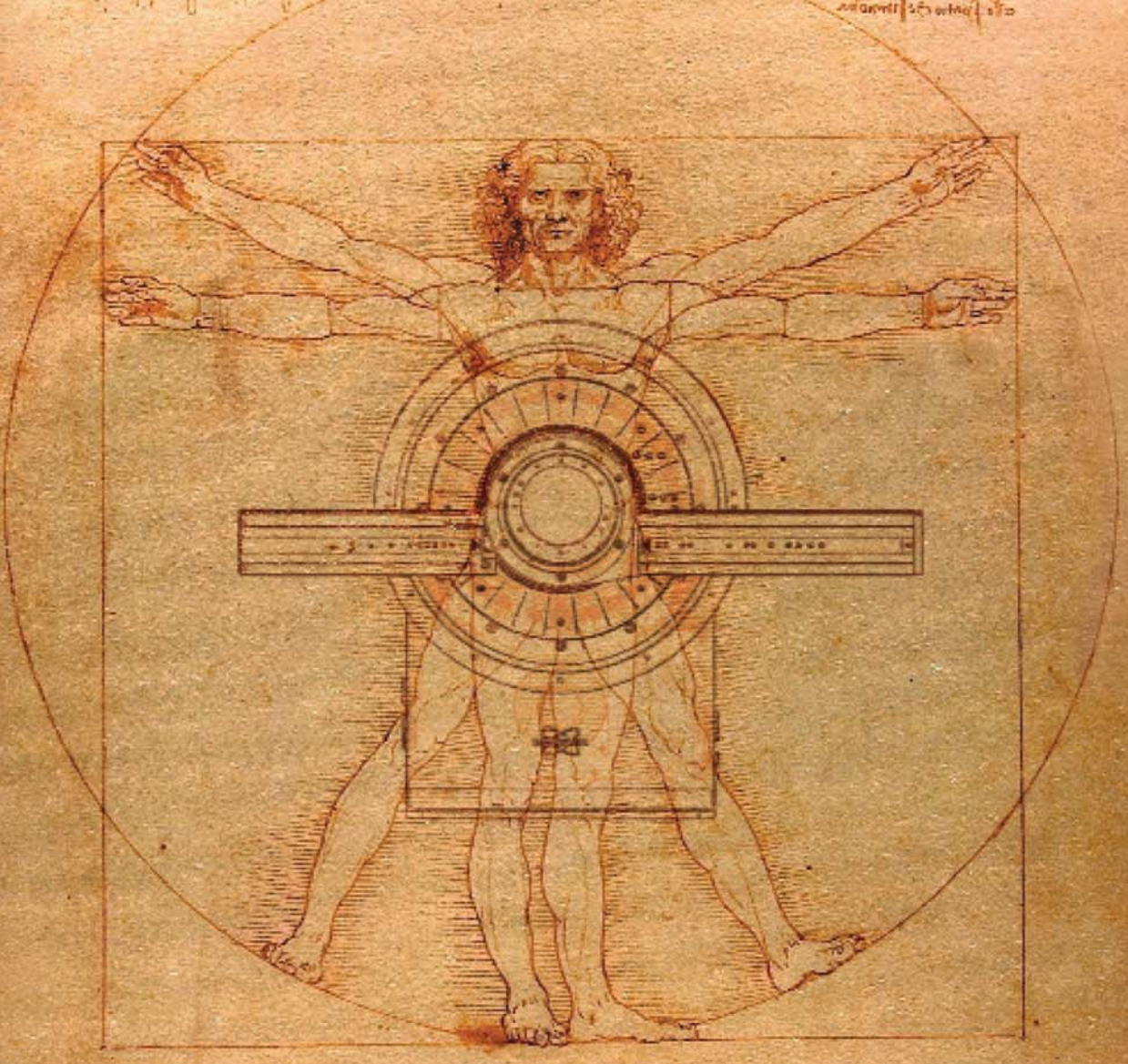

Handwritten text in a cursive script, likely a continuation of the text from the top of the page. It is positioned directly below the main drawing.

Handwritten text in a cursive script, likely the concluding text of the page. It is positioned at the bottom of the page, below the second line of text.

Handwritten text in a cursive script, likely a signature or a date, located in the bottom right corner of the page.

- True plug & play functionality with fully automatic component recognition and configuration
- Alignment-free switch of configurations – whatever your sample, whatever your application
- Absolutely open design with maximum flexibility for future adaptations

D8 ADVANCE and DAVINCI.DESIGN – the world’s 1st genuine all-purpose diffractometer for everyone

We are proud to present the new generation of our D8 ADVANCE with an abundance of unparalleled innovations.

The D8 ADVANCE with DAVINCI.DESIGN facilitates a pioneering diffractometer concept, which eliminates the problems of awkward configuration and adjustments once and for all. It is extremely easy to exchange all components and geometries.

The D8 ADVANCE with DAVINCI.DESIGN is a uniquely modular system, incorporating all parts of the beam path without any restriction. From the X-ray tube, through optics and sample stages all the way to the detectors, any user – even those with no experience – is capable of changing from one beam geometry to another or exchanging individual components with no trouble at all. Therefore, our D8 ADVANCE offers unparalleled adaptability to any conceivable application in X-ray diffraction. Our multilevel design is especially revolutionary and offers you as a user permanent support as well as doing all the hard work for you:

Rely on the “Da Vinci trio”!

**DAVINCI.MODE
DAVINCI.SNAP-LOCK
DIFFRAC.DAVINCI**

- Failure-safe operation thanks to real-time validation of components
- Detection of missing or unsuitable components
- True plug & play functionality for all components: tubes, optics, sample stages, detectors
- Tool-free change of all optical components in a second
- Alignment-free change between different instrument geometries and applications
- Push-button-motorized switch between Bragg-Brentano and parallel-beam geometry with TWIN optics
- The virtual goniometer: real-time software representation of the real goniometer with all components
- Software-guided and -validated instrument configuration with real-time conflict detection
- Missing or forgotten instrument details and measurement parameters are a thing of the past



DAVINCI.MODE:

- real-time component recognition and configuration
- real-time conflict detection



LYNXEYE 1-D detector:

- active area 14.4 x 16 mm, covering > 3° (2 θ)
- dedicated version for hard radiation



VÅNTEC-1 1-D detector:

- active area 50 x 16 mm, covering > 13° (2 θ)
- very low noise level below 0.01 cps



SOL-XE detector:

- true energy-dispersive detector
- no need for a secondary monochromator



SNAP-LOCK:

- fast and easy: changing optics without tools
- alignment-free: all optics retain their alignment



AUTO-CHANGER:

- huge sample throughput with up to 90 samples
- for reflection and transmission mode



Compact XYZ stage:

- all drives motorized and software-controlled
- additional sample holders for unrivaled flexibility



Compact Eulerian cradle:

- motorized and software-controlled phi and chi
- ideal stage for stress and texture measurements

The “Da Vinci trio” for one purpose: uncompromised ease of use



TWIN optics:

- for primary and secondary beam
- push-button switch between geometries



Primary monochromator:

- focusing monochromator for best data quality
- No radiation for highly absorbing materials



Humidity chamber:

- fully integrated temperature and humidity control
- humidity experiments between room temperature and 90 °C



Capillary furnace:

- compact furnace design
- measurements up to 1,000 °C with fully integrated temperature control

DAVINCI.MODE

In the DAVINCI.MODE, your D8 ADVANCE monitors and controls itself in all details. The system knows its own state at all times. Each component, each component replacement, and each change of status is automatically recognized. Each component registers itself with its specific characteristics on the system and is then configured automatically. Thanks to DAVINCI.MODE, it is no longer necessary to make any adjustments after exchanging a component.

DAVINCI.SNAP-LOCK

DAVINCI.SNAP-LOCK is our unique, high-precision SNAP-LOCK mechanism, which enables all of the optics to be exchanged within just a few seconds. Without tools and – due to DAVINCI.MODE – without any adjustments; all optics return to perfect alignment every time. Never before has it been so easy, fast and reliable to change configurations.

DIFFRAC.DAVINCI

DIFFRAC.DAVINCI is the intelligent virtual goniometer, which completes the DAVINCI.DESIGN and opens up new, previously unknown possibilities. DIFFRAC.DAVINCI is a graphical representation of the actual goniometer showing all beam path components plus their status and providing automatic validation of the instrument configuration with real-time conflict detection. DIFFRAC.DAVINCI offers two modes of operation:

1. The Instrument Control Mode to configure the instrument for immediate measurements using the DIFFRAC.COMMANDER software.
2. The Measurement Planning Mode allows creating measurement methods using the DIFFRAC.WIZARD software, providing a graphical definition of the desired instrument configuration.

DAVINCI.DESIGN:
Intuitive – fail-safe – easy.

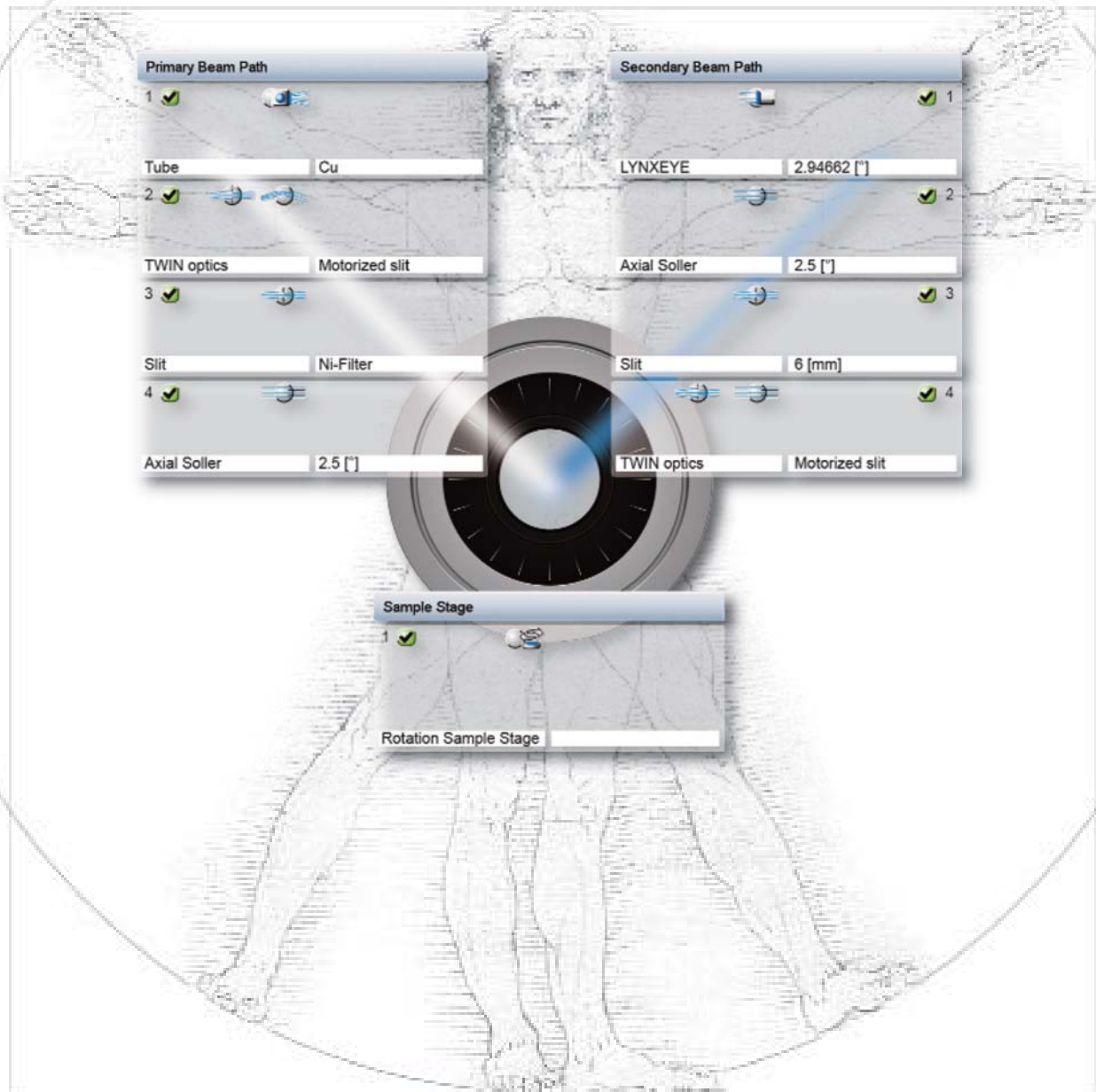



DAVINCI.SNAP-LOCK

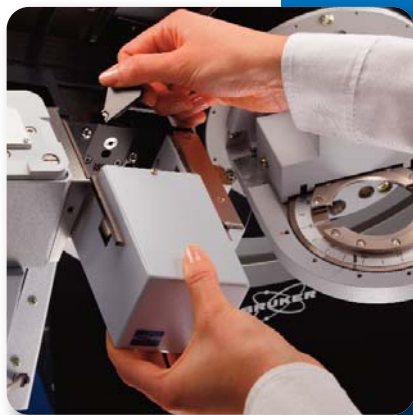

DIFFRAC.DAVINCI

The virtual goniometer:

- ① Instrument Control Mode
 - Real-time component recognition and status display
 - Push-button switch between Bragg-Brentano and parallel-beam geometry with TWIN optics
- ② Conflict detection
 - Detection of missing, misplaced or unsuitable components
- ③ Measurement Planning Mode
 - Choice between all components configured for the present system
 - Parameterization of all fixed and motorized components, e.g. slit sizes, absorber thickness, instrument geometry (TWIN optics setting)



- Ultimate X-ray, machine and electric safety in compliance with the latest EU directives
- Audit-proven quality management system
- Ergonomic, clearly visible and fail-safe warning and operator control elements
- Every experiment can be repeated years later with exactly the same instrument configuration and measurement parameters

Good Diffraction Practice – absolute safety is our top priority



Before we ever release a new instrument, we have already passed all audits regarding safety and standards. Each instrument always complies with the world's highest statutory requirements regarding X-ray, machine and electrical safety. This confidence is obtained after stringent scrutiny by independent institutions.

Regarding X-ray safety, the following applies: Even under extraordinary test conditions, any location outside the cabinet of our D8 ADVANCE will exhibit significantly less than one micro-Sievert per hour, in accordance with EURATOM instructions. Irrespective of the instrument configuration, under measurement conditions, the radiation level is in the nano-Sievert range.

Two independent, fail-safe safety circuits with separate shutter and "X-ray On" monitoring guarantee that the most recent radiation and personnel safety regulations are observed. Furthermore, all warning and operating elements are installed ergonomically, clearly visible, and coordinated with one another in an elegant and state-of-the-art design.

Design and development of our systems comply with certified ISO 9001:2008 and GAMP processes and procedures.

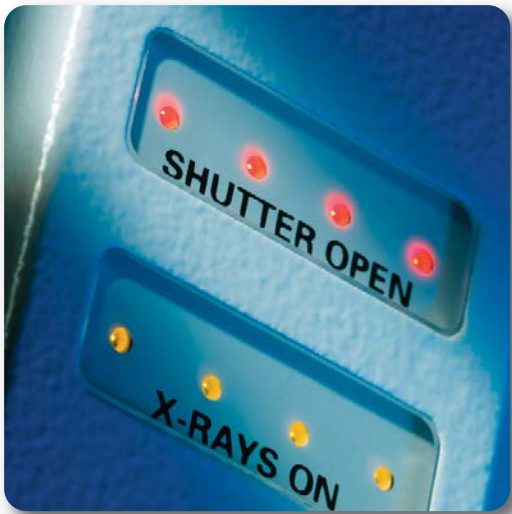

X-ray tube LED status display



Instrument ON status



Smart screen keys for instrument status display



Instrument status display in software

Conforms to:
 96/29/EURATOM
 RöV
 DIN EN 954-1 Cat. 3
 2006/42/EG
 DIN EN 61010-1/2
 CSA C22.2 No. 1010
 EN 61000-6-1/-2/-3/-4

... and many more

Approved by:
 TÜV
 PTB
 BfS
 NEMKO



VANTEC-1 1-D detector



LYNXEYE 1-D detector



SOL-XE energy-dispersive detector



Scintillation counter

Instrument alignment – a sound base for accuracy!

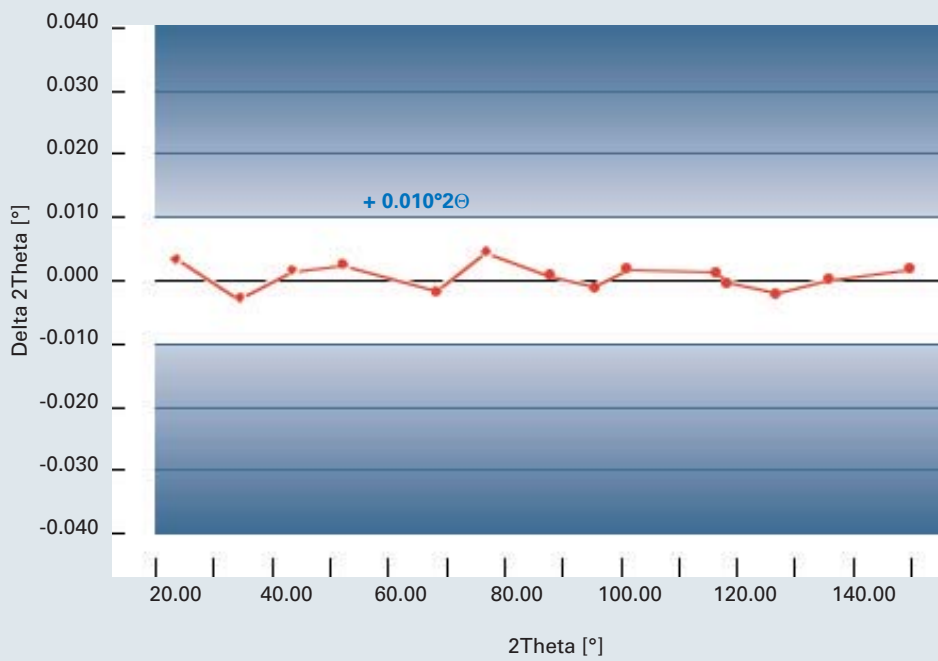

- Instrument alignment $\pm 0.01^{\circ} 2\Theta$ over the whole angular range – guaranteed!
- Why is this important? Accurate and verifiable instrument alignment is a basic requirement for accurate and reliable data.

Best-Data Guarantee – the kind of quality you can trust

1) Alignment Guarantee: We guarantee that the accuracy of each peak position over the entire angular range is better than $\pm 0.01^\circ 2\theta$!

Before delivery and during installation, every single instrument must pass a strict test based on the internationally accepted Standard Reference Material (SRM) 1976a supplied by the American National Institute of Standards and Technology (NIST). This standard is always included in the delivery, enabling you to monitor instrument performance at any time.

2) Detector Guarantee: We guarantee absolutely faultless detectors, without any defective detector areas!

This is due to Bruker AXS' proprietary detector design of LYNXEYE and VÅNTEC-1. Bruker AXS' 100% quality distinguishes its detectors and means that they guarantee the best possible data.

Best-Data Guarantee – unique at Bruker AXS.

- Solid and maintenance-free goniometer design for mechanical strength and long life
- Instrument performance verification with NIST corundum standard SRM 1976a
- Instrument alignment $\pm 0.01^\circ 2\theta$ over the whole angular range
- Optional IQOQ procedures for regulated industries such as the pharmaceutical industry
- LYNXEYE compound silicon strip detector with all channels fully functional
- VÅNTEC-1 detector with patented MIKROGAP technology for large 2θ coverage without defective areas

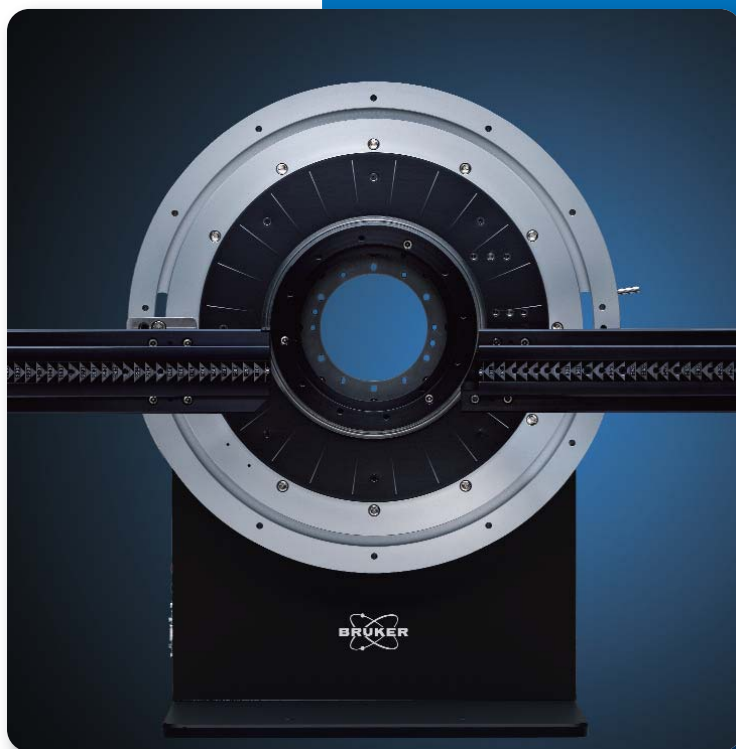

Ultra-high-precision goniometer

Everything is possible – D8 ADVANCE

No matter whether you are interested in the position, the intensity or the shape of the diffraction peaks, our D8 ADVANCE provides the best possible data quality in the shortest time for all applications. Unrivaled and guaranteed: thanks to Bruker AXS' DAVINCI.DESIGN and Best-Data Guarantee!

Irrespective of how varied your applications, tasks and samples may be, analysis becomes so simple with our D8 ADVANCE. Thanks to its modularity and our DAVINCI.DESIGN, you can always configure a D8 ADVANCE exactly to satisfy your analytical needs! The D8 ADVANCE is the basis that guarantees your success.

This is how you use DAVINCI.DESIGN:

Define the task, select the desired beam geometry, optics, sample stage and detector. Put your desired configuration together in a few steps – and it's done! The rest: component identification, configuration and adjustment are carried out completely without user intervention by DAVINCI.MODE.

Powder diffraction has never been so simple, flexible and reliable. D8 ADVANCE with DAVINCI.DESIGN – revolutionary ease of use with uncompromised data quality!

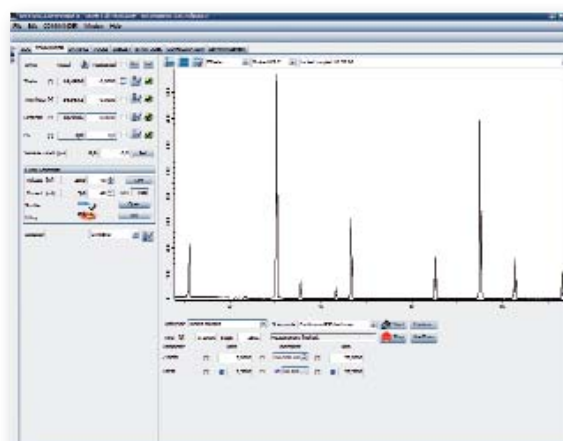

Data acquisition with
DIFFRAC.COMMANDER

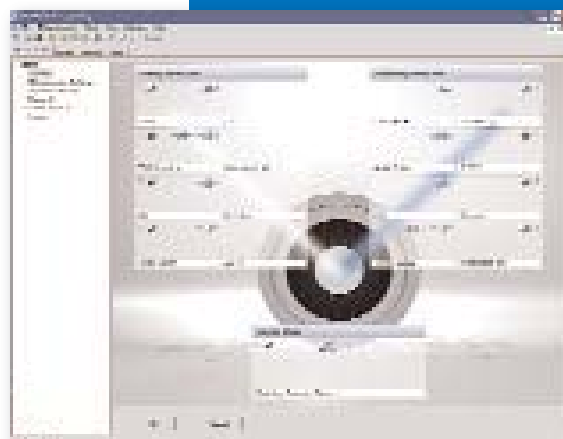

Instrument setup planning
with DIFFRAC.WIZARD

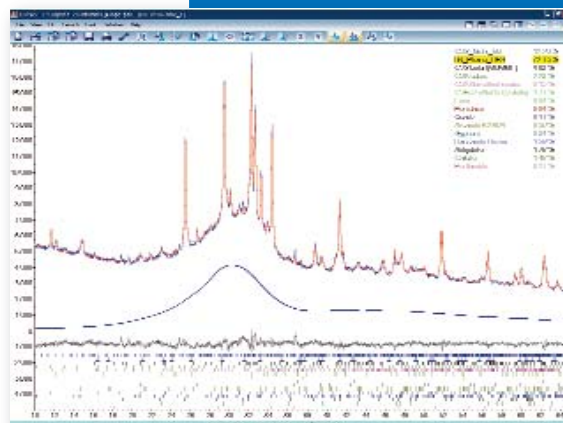

Quantitative phase analysis
with DIFFRAC.TOPAS

Unlimited flexibility and upgrade-ability thanks to DAVINCI.DESIGN

Completely new DIFFRAC.SUITE software package for instrument control and data evaluation

Free choice between all D8 ADVANCE optics and detectors



Bragg-Brentano geometry with LYNXEYE detector

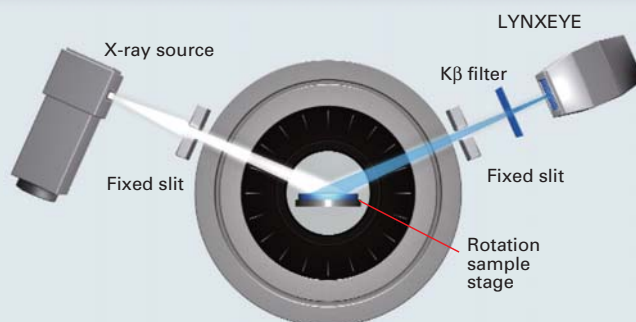

- Up to 500 times faster with SUPER SPEED LYNXEYE or VÅNTEC-1
- Unique radial Soller slit for VÅNTEC-1 for lowest background
- Large energy-dispersive SOL-XE detector for best peak-to-background ratio

Intelligent sample handling:

- 9-position FLIP-STICK and 90-position AUTO-CHANGER for reflection and transmission
- Sample loading at any time
- Definition of priority samples
- Automatic resumption of interrupted measurements



Bragg-Brentano geometry with energy-dispersive SOL-XE detector

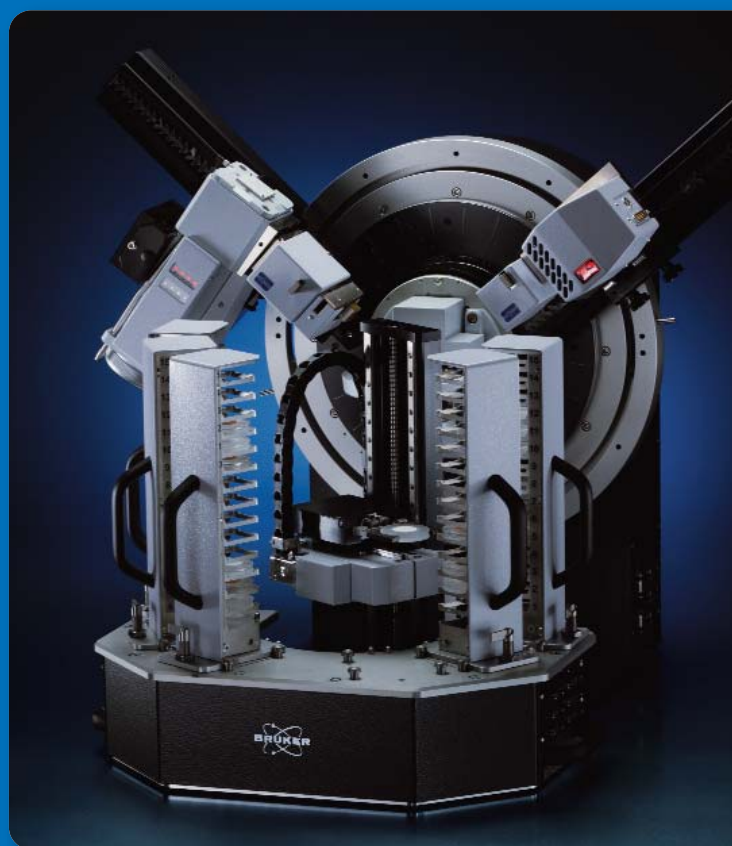

High-throughput diffraction with LYNXEYE detector and AUTO-CHANGER

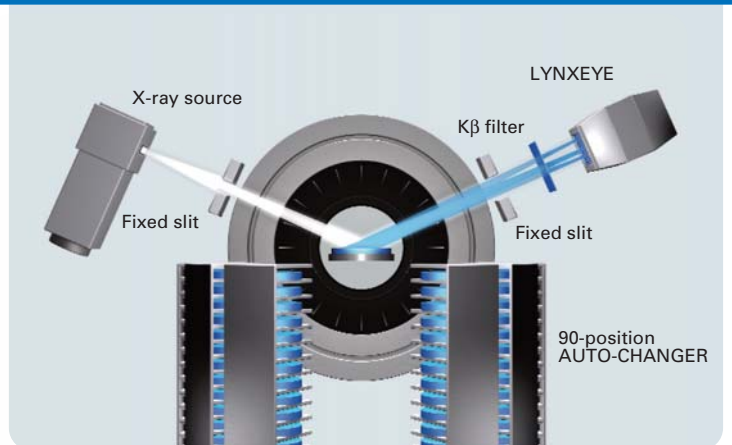
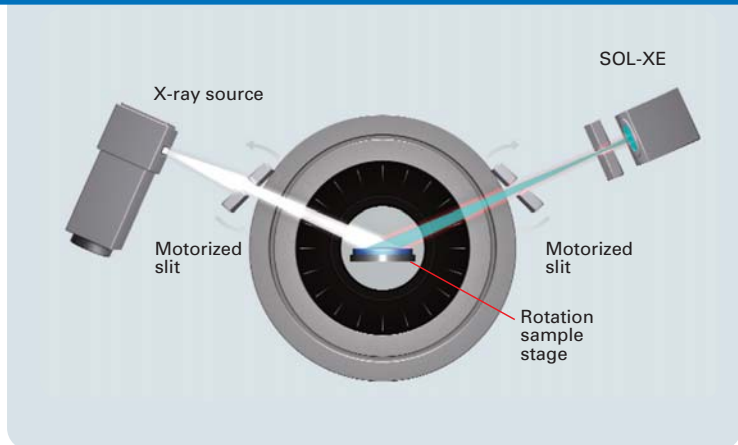



Phase identification with DIFFRAC.EVA

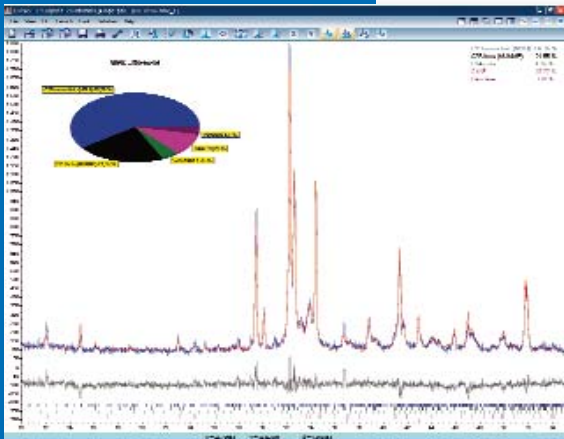

Phase quantification with DIFFRAC.TOPAS



Screening and quality control with DIFFRAC.POLYSNAP

More speed, more samples, more sensitivity: D8 ADVANCE

There are many tasks for which you simply need more intensity and higher sample throughput. Hence, our D8 ADVANCE offers a host of high-performance components for all applications.

Our 1-D detectors, LYNXEYE and VANTEC-1, are what make high-resolution data collection possible in an extremely short time. These two unique detectors are both SUPER SPEED components. They enable performance to be enhanced up to a factor of 500, either in terms of intensity or sample throughput!

If your analysis results are impaired by sample fluorescence, then the energy-dispersive SOL-XE detector will be your first choice. The SOL-XE provides an excellent peak-to-background ratio because it suppresses sample fluorescence and $K\beta$ radiation almost entirely.

High intensities and short measurement times naturally facilitate a correspondingly high sample throughput. The D8 ADVANCE is also excellently equipped for this. With the FLIP-STICK sample stage or our AUTO-CHANGER, it is possible to meet all requirements. These multisample stages can be used in reflection and transmission mode with almost all types of samples: powder, bulk, suspensions, small sample quantities, air-sensitive samples ...



Advanced applications: easy transmission with the D8 ADVANCE

The properties of the sample determine which instrument geometry is best: transmission or reflection. Therefore, the D8 ADVANCE affords you the freedom to choose.

For small sample quantities, preferred orientations, organic materials with low absorption coefficients, sensitive samples, fluids ... measurements in transmission geometry are the top choice. For applications such as structure analysis, kinetic processes or Small Angle X-ray Scattering (SAXS), this is the preferred setup as well. Achieve the best results for these tasks, with the most advantageous components and DAVINCI.DESIGN.

Let's begin with the primary optics. We advise to use our focusing Göbel mirror for highest intensity. Our primary monochromator guarantees even better data quality with pure $K\alpha_1$ radiation. These optics are both excellent for SAXS experiments as well.

Preparation in capillaries or between foils, analysis of solid samples or powders, measurements at high or low temperatures are all concerns of your application. No matter which choice you make, all components are identified and configured fully automatically without any further adjustments. Even the question of transmission or reflection is not a prior concern with our FLIP-STICK and AUTO-CHANGER. It is possible to change between two geometries conveniently from your workstation.

And, last but not least, there is always the question of data quality and measurement time. With the SUPER SPEED components, LYNXEYE and VANTEC-1, transmission measurements are performed in minutes thanks to the simultaneous capture of large 2θ angles and extreme sensitivity to signals.

Meet the D8 ADVANCE in transmission.

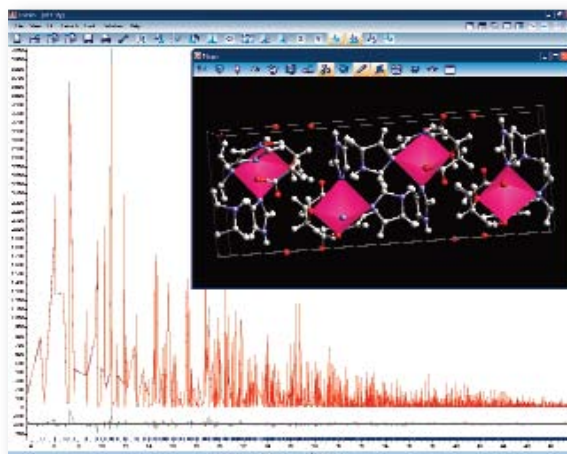

Crystal structure determination with DIFFRAC.TOPAS

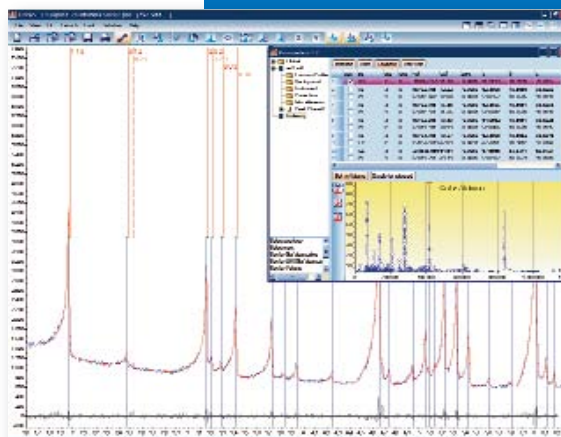

Indexing with DIFFRAC.TOPAS

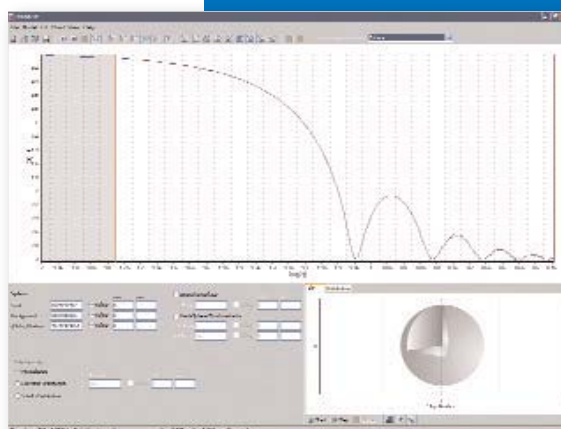

SAXS with DIFFRAC.NANOFIT

- Johansson monochromators for all common wavelengths from Cr to Mo
- Best data quality with parallel and focusing Göbel mirrors for all common wavelengths
- Software-controlled switch between reflection and transmission with parallel-beam Göbel mirrors
- Unmatched crystal structure and nano structure analysis



Tablet screening



Capillary furnace



Capillary geometry with Johansson monochromator for pure $K\alpha_1$ radiation and VANTEC-1 detector, with unique radial Soller to reduce diffuse scattering



High-throughput diffraction with LYNXEYE detector and AUTO-CHANGER

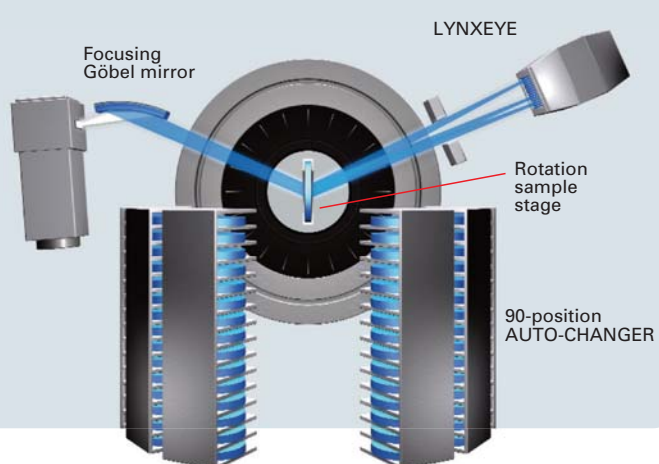
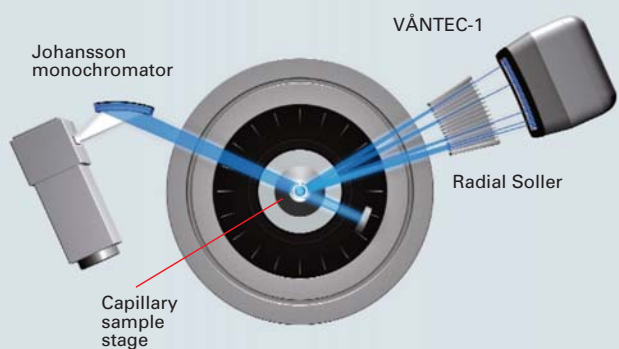

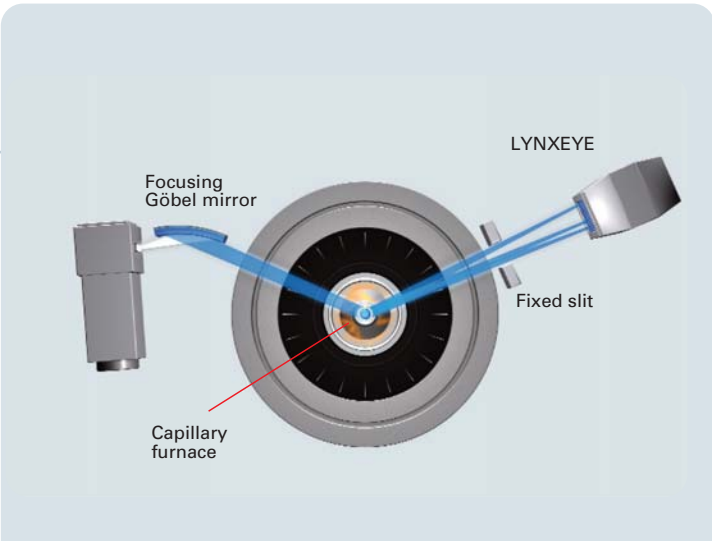

- Reactive atmospheres and high-pressure experiments
- Non-ambient experiments in reflection and capillary geometry from 10 K up to 2,300 °C
- Superior VANTEC-1 detector with large angular coverage and unique radial Soller for both scanning and SNAPSHOT mode
- Humidity experiments from room temperature up to 90 °C, fully software-integrated
- Temperature-dependent reflectometry from -180 °C up to 800 °C



High-speed humidity measurements with the HOT HUMIDITY system and VANTEC-1 detector



HTK1200N oven and LYNXEYE detector

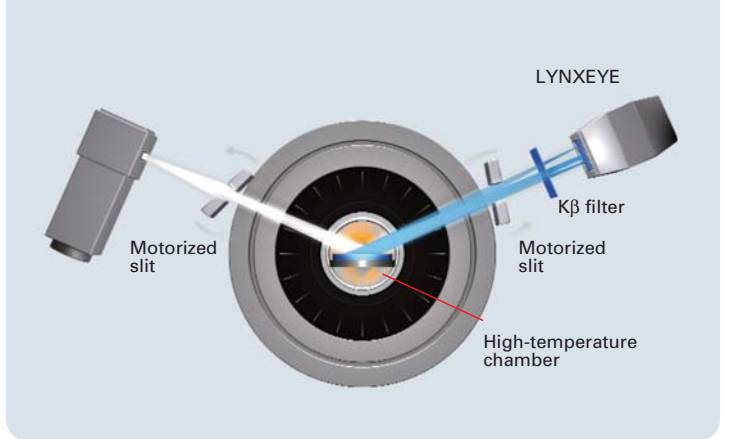
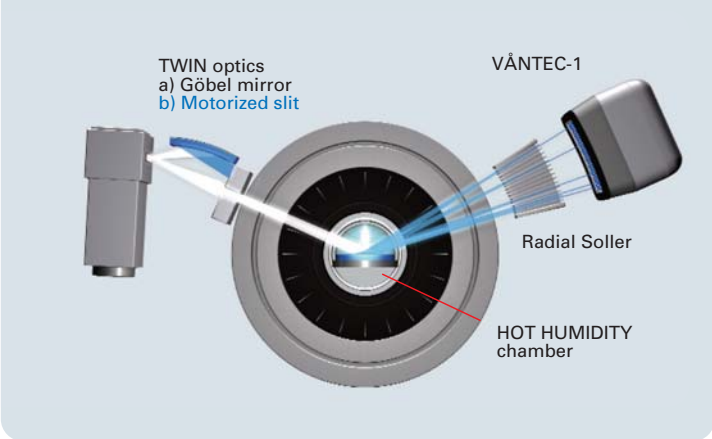

D8 ADVANCE – your sample under controlled non-ambient conditions

The properties of your samples can change under the influence of temperature, pressure, atmosphere or humidity. What could be more obvious than to simulate these conditions and to equip the D8 ADVANCE with one of the many sample chambers and 1-D detectors that enable you to study the impact “in situ” in the laboratory?

Two unique components enable the D8 ADVANCE to observe fast changes of sample properties: our LYNXEYE and our VÅNTEC-1 detectors.

To obtain outstanding data quality in FAST-SCAN mode, you can complement the VÅNTEC-1 with our radial Soller to suppress scattering not coming from the sample, such as air scattering.

It goes without saying that the entire control of the sample chambers is integrated in our DIFFRAC.SUITE and the chambers are identified automatically, thanks to DAVINCI.MODE. Hence it is very easy for you to graphically create even complex measuring sequences.

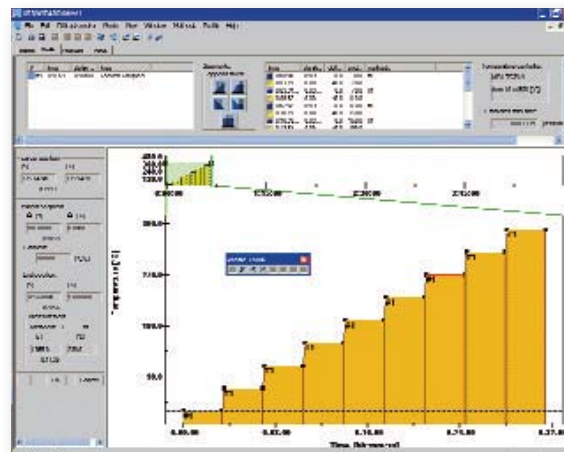

DIFFRAC.WIZARD to set up high-temperature experiments

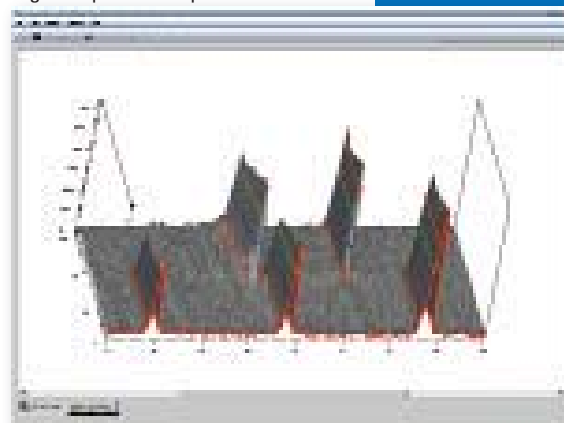

3-D view with DIFFRAC.EVA

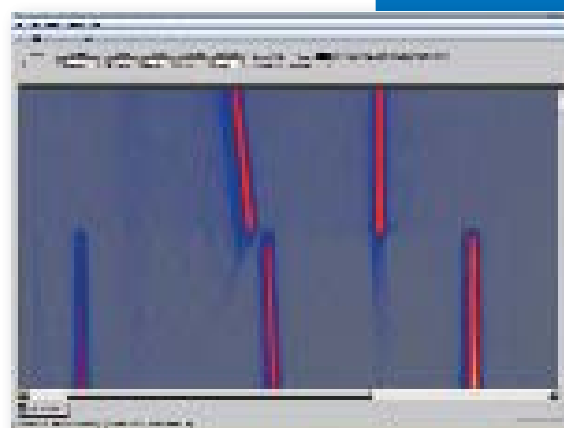

Iso-intensity view with DIFFRAC.EVA

- Maximum flexibility with TWIN optics for primary and secondary beam path
- Push-button switch between Bragg-Brentano and parallel-beam geometries
- Superb LYNXEYE detector for a wide variety of applications



TWIN/TWIN setup in Bragg-Brentano geometry

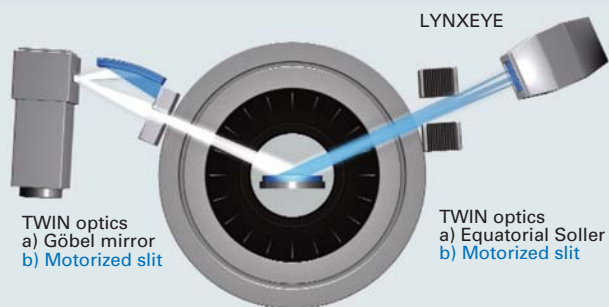

- Primary TWIN optics set to Göbel mirror for highest flux density
- LYNXEYE in 0-D mode and turned by 90° to cover an extremely large dynamic range
- Film thickness from 0.1 nm up to 200 nm
- Standardless density, roughness, and stackings determination with highest accuracy



KNIFE EDGE collimator for reflectometry



LYNXEYE detector in 0° and 90° position



Reflectometry TWIN/TWIN setup with LYNXEYE detector in 90° position

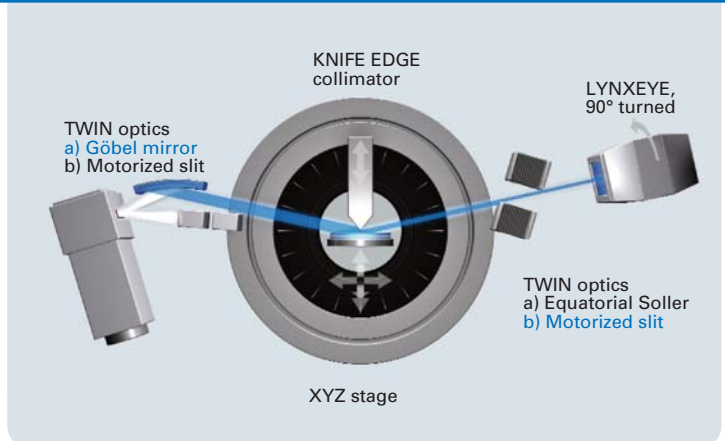

- Primary TWIN optics set to Göbel mirror for highest flux density
- Secondary TWIN optics for push-button switch to equatorial Soller slit
- LYNXEYE in O-D mode for high-resolution parallel-beam geometry
- Grazing incidence diffraction for optimum thin-film diffraction signals

- Primary TWIN optics set to Göbel mirror for highest flux density
- LYNXEYE in 1-D mode for fast data collection
- Software-controlled sub-micron sample mapping with versatile compact XYZ stage
- Fast and accurate sample positioning with double-laser system



Grazing incidence diffraction TWIN/TWIN setup



Microdiffraction TWIN/TWIN setup

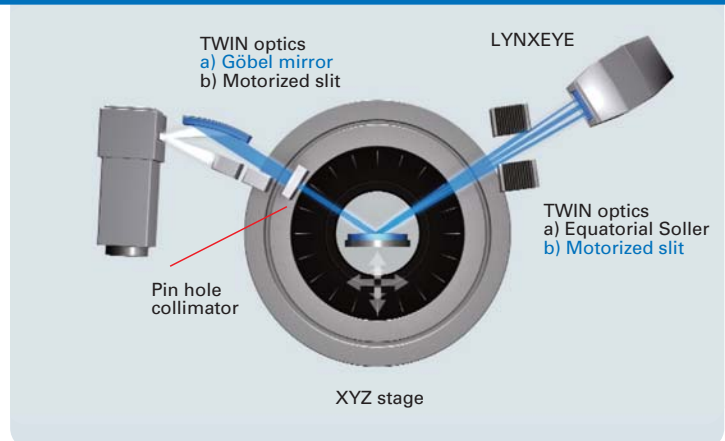
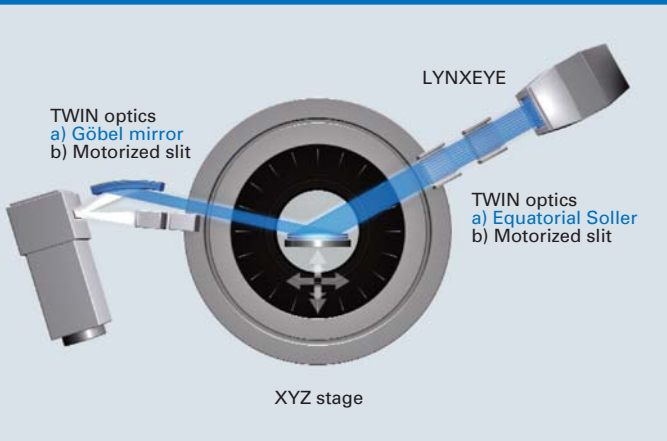

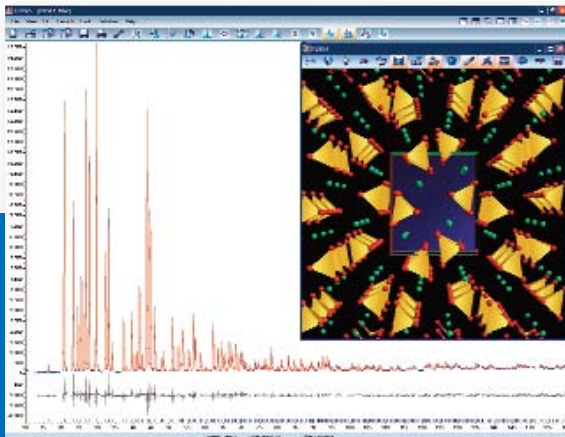

Structure analysis with DIFFRACTOPAS

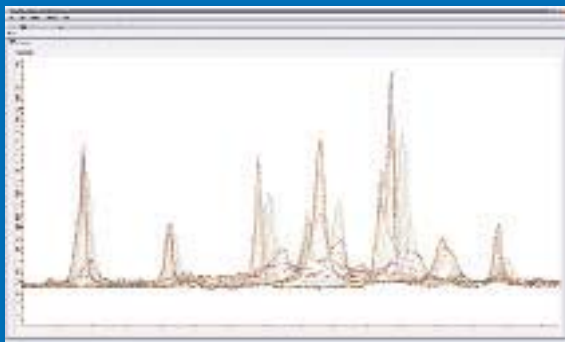

Phase identification with DIFFRACT.EVA

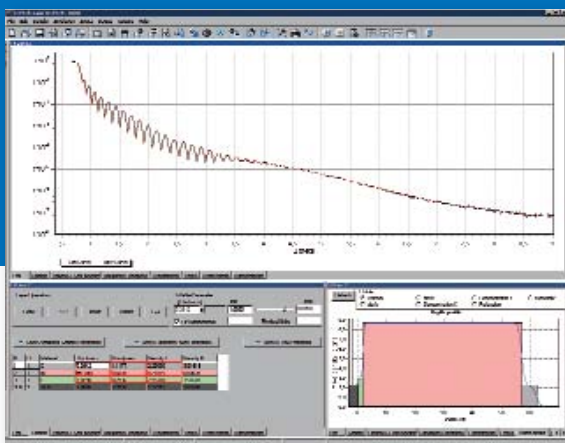

Reflectometry analysis with DIFFRACT.LEPTOS

Ultimate flexibility and push-button ease of use – D8 ADVANCE with TWIN/TWIN setup

Imagine you could easily switch between such diverse applications as phase ID or reflectometry (XRR), or between grazing incidence diffraction (GID) and microdiffraction (μ XRD), or between investigations of residual stress and structure determination ... without even touching the optics. Wouldn't that be brilliant? Yes! That is exactly what our D8 ADVANCE with DAVINCI.DESIGN has been made for: TWIN/TWIN setup.

With the TWIN optics on the primary side, you can switch with motor support between Göbel mirror for parallel-beam geometry and a variable divergence slit for Bragg-Brentano geometry. With the secondary TWIN, you can change between an equatorial Soller slit and a variable slit. If all of this is complemented by the desired sample stage and our unique LYNXEYE detector, you have the most flexible diffractometer in the world!

For the switch between different geometries, you do not have to get up from your desk or make adjustments of any kind. One mouse click and the new beam path is ready to measure. DAVINCI.DESIGN makes it possible.

Do you need any other optics, filters, slits or sample stages? No problem! Simply snap-in the desired optics or exchange the sample stage and DAVINCI.MODE takes care of the rest.

**Our D8 ADVANCE with TWIN/TWIN setup:
no compromises, superb variability and
more time for pure measurements!**

Switching from line to point focus – no big deal: TWIST-TUBE

Most powder diffraction applications on polycrystalline samples are done with line focus. For texture measurements, point focus is most suited. Hence, fast and easy switching between line and point focus is a stunning feature for a true all-purpose diffractometer.

With conventional instrumentation, one has no choice but to drain off the cooling water, exchange the tube, plug the cable again etc. – and, at great effort, convert the geometry. Then switch on, ramp up and readjust ...

No more! Thanks to TWIST-TUBE technology, designed and patented by Bruker AXS, you can now conveniently switch between line and point focus applications.

This is how our TWIST-TUBE works: Release fixtures, rotate tube head, fix in position and measure! To do so, you do not have to disconnect cables or unscrew tubes. DAVINCI.MODE takes care of the rest because the system identifies the appropriate configuration automatically.

Easy TWIST-TUBE texture!



Compact Eulerian cradle with XY stage



TWIST-TUBE head



Changing the tube focus



Texture setup with TWIST-TUBE

- Patented TWIST-TUBE design compatible to standard tube dimensions
- Fast and easy switching of the tube focus orientations
- No realignment and automatic focus orientation detection thanks to DAVINCI.MODE
- No need to disconnect cables and hoses

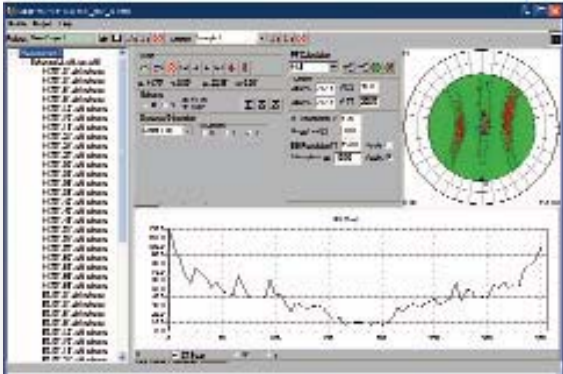

Texture analysis with DIFFRAC.MULTEX

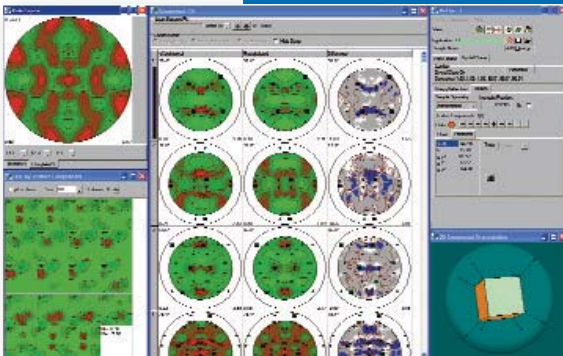

Texture analysis with DIFFRAC.MULTEX



Straightforward measurement design with DIFFRAC.WIZARD



Typical texture setup with the TWIST-TUBE and compact Eulerian cradle

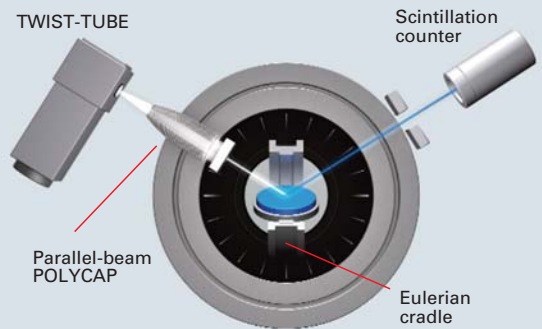

- XYZ stage for accurate sample positioning and mapping
- VÅNTEC-1 for SNAPSHOT residual stress investigations
- Fast and accurate sample positioning with double-laser system
- Traditional $\sin^2(\psi)$ method as well as the multi hkl evaluation method
- From normal and shear stress up to the complete stress tensor
- Retained austenite determination based on both the traditional RIR and Rietveld method for complex alloys

- Easy change to the ideal texture configuration – TWIST-TUBE and DAVINCI.DESIGN
- Compact Eulerian cradle for both iso- and side-inclination modes
- POLYCAP for high-speed, high-flux texture analysis
- Intelligent setup of measurement schemes with DIFFRAC.WIZARD
- Texture determination based on the component method or the traditional spherical harmonics method



Stress measurements in iso-inclination (ω) mode



Texture or stress measurements in side-inclination (ψ) mode

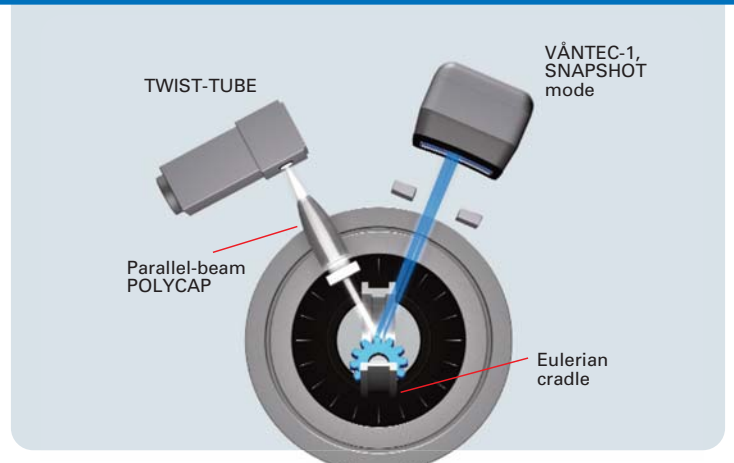
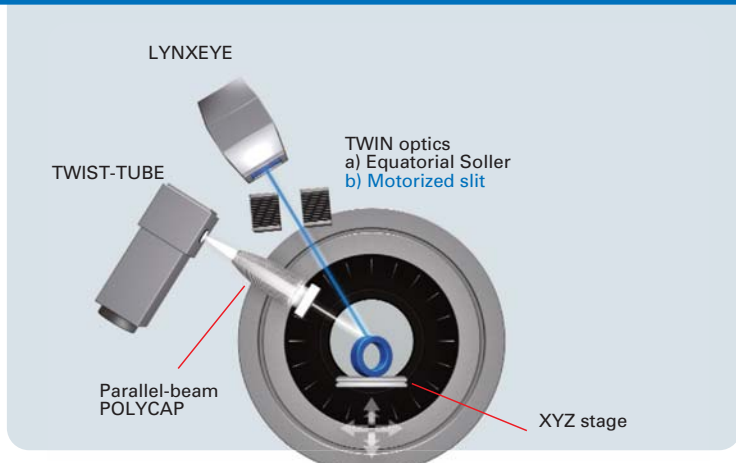

Texture and residual stress – take it easy with the D8 ADVANCE

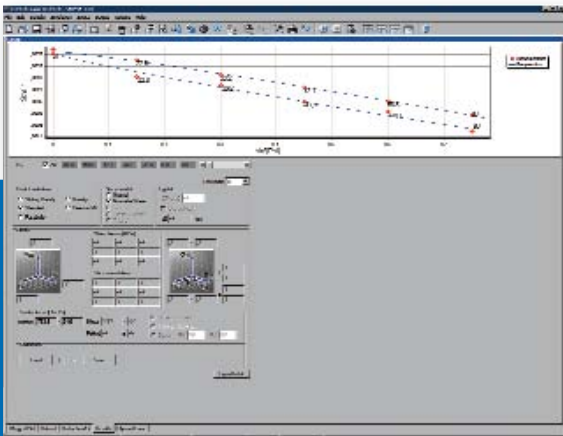

Residual stress analysis with DIFFRACT.LEPTOS

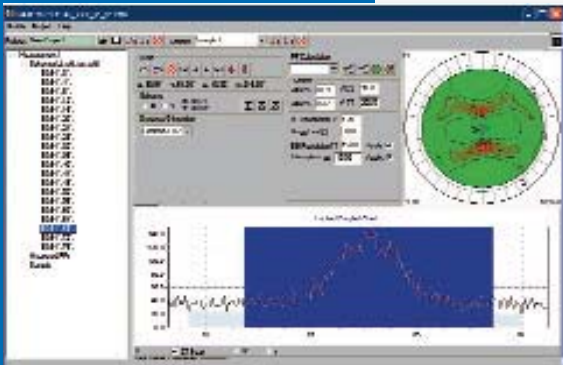

Texture analysis with DIFFRACT.MULTEX

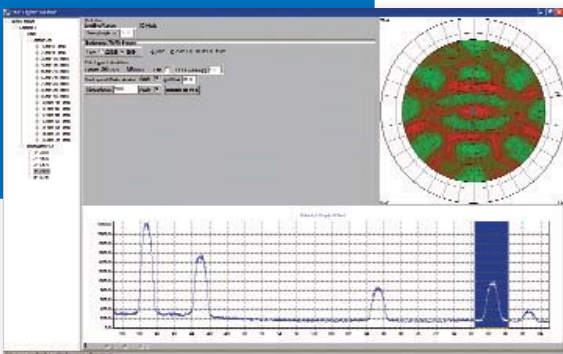

Texture analysis with DIFFRACT.MULTEX

When examining stress and texture of machined items, one actually analyzes the crystallite deformation and orientation distribution locally. That requires a maximum number of possibilities for aligning the sample, obtaining maximum intensity at a particular spot, and obtaining maximum resolution and detection area.

Voilà, the D8 ADVANCE!

Maximum degrees of freedom:

With our extremely compact, high-precision Eulerian cradle, you can automatically rotate and incline your sample (ϕ , χ). Alternatively, the compact XYZ stage provides the possibility for the controlled alignment and mapping of samples in all directions.

Maximum intensity:

Higher intensity means less measurement time. Furthermore, one often requires the intensity at only one specific point. This is what our POLYCAP lenses are for.

Maximum resolution and maximum speed:



Anyone requiring maximum resolution and maximum speed will, of course, use our SUPER SPEED detectors – LYNXEYE and VANTEC-1.

D8 ADVANCE – leaving your competition far behind!



Applications

Phase Identification
Phase Quantification
Microstructure Analysis
Structure Analysis
Residual Stress
Texture
Reflectometry
Small Angle X-ray Scattering

-  No match,
due to physical limitations
-  Match
-  Perfect match

Technical Data

Configurations	Vertical goniometer, Theta/2Theta or Theta/Theta geometry
Measuring circle diameter (depending on set-up)	Predefined at 500 mm, 560 mm and 600 mm or any intermediate setting
Angular range (without accessories)	360°
Max. usable angular range (depending on accessories)	-110° < 2Theta 168°
Angle positioning	Stepper motors with optical encoders
Smallest addressable increment	0.0001°
Instrument alignment (at constant climate)	Equal or better than ± 0.01° 2Theta; NIST SRM 1976a always included
Maximum angular speed (depending on accessories)	20°/s
Detectors	Point detectors: Scintillation counter SOL-XE energy dispersive 1-D detectors: LYNXEYE VANTEC-1 All detectors guaranteed without defective/dead strips or areas
General space and infrastructure requirements:	
Exterior dimensions (h x w x d)	1,868 x 1,300 x 1,135 mm 73.5 x 51.2 x 44.7 inch
Weight (without optional electronics)	770 kg
Cooling water supply (without optional internal water chiller)	Min. 4 l/min, pressure 4 bar to 7.5 bar, no pressure on outlet side, temperature: 10 °C to 20 °C
Power supply	Single phase: 208 to 240 V Three phases: 120 V, 230 V, 240 V; 47 to 63 Hz
Maximum power consumption (without controllers for optional equipment)	6.5 kVA

www.bruker-axs.com

● **Bruker AXS GmbH**

Karlsruhe, Germany
Tel. +49 (7 21) 5 95-28 88
Fax +49 (7 21) 5 95-45 87
info@bruker-axs.de

Bruker AXS Inc.

Madison, WI, USA
Tel. +1 (800) 234-XRAY
Tel. +1 (608) 276-3000
Fax +1 (608) 276-3006
info@bruker-axs.com

TWIST-TUBE:
DE 10 2006 053 760 B4 patent
MIKROGAP technology, VANTEC-1:
US 6,340,819 B1 patent
LYNXEYE turned 90°:
EP 1 647 840 A2 patent;
EP 1 510 811 B1 patent