

Thermal Analysis Excellence

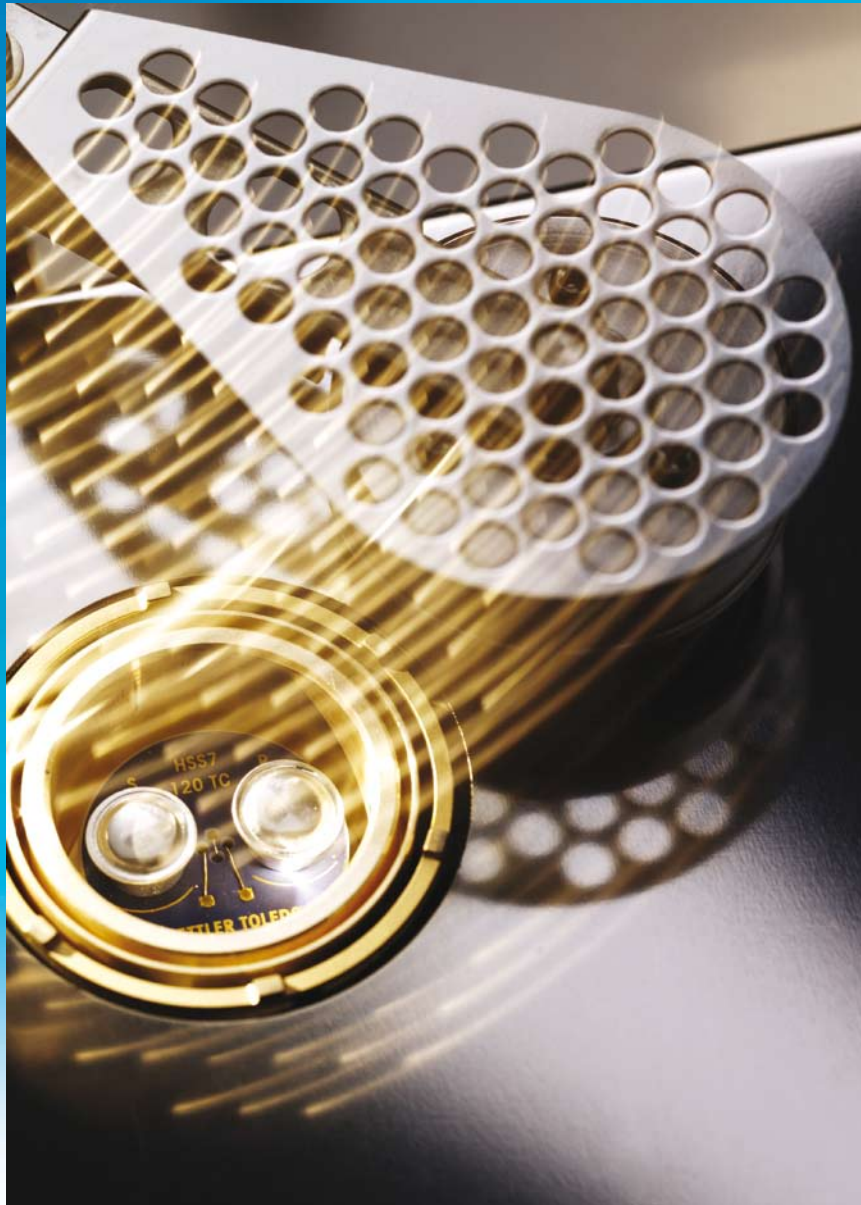

DSC 1

STAR[®] System

Innovative Technology

Versatile Modularity

Swiss Quality



Differential Scanning Calorimetry for all Requirements

METTLER TOLEDO

Unmatched DSC Performance

Tailored Exactly to Your Needs

Differential scanning calorimetry (DSC) is the most frequently used thermal analysis technique. DSC measures enthalpy changes in samples due to changes in their physical and chemical properties as a function of temperature or time.

Features and benefits of the METTLER TOLEDO DSC 1:

- **Amazing sensitivity** – for the measurement of weak effects
- **Outstanding resolution** – allows measurement of rapid changes and close-lying events
- **Efficient automation** – reliable sample robot for high sample throughput
- **Small and large sample volumes** – for microgram or inhomogeneous samples
- **Modular concept** – tailor-made solutions for current and future needs
- **Flexible calibration and adjustment** – guarantees accurate and precise measurement results under all conditions
- **Wide temperature range** – from -150 °C to 700 °C in one measurement
- **Ergonomic design** – intelligence, simplicity and safety facilitate your daily work

Thanks to its modular design, the DSC 1 is the best choice for manual or automatic operation, from quality assurance and production through to research and development.

The DSC utilizes an innovative patented DSC sensor with 120 thermocouples which guarantees unmatched sensitivity and resolution.



DSC 1 from METTLER TOLEDO

the Right Decision

SmartSens terminal

The color touchscreen terminal allows visual contact with the instrument, even from a distance and indicates the status of the measurement. You can enter individual sequences and queries directly at the terminal, switch the screen display and open and close the furnace using the intuitive touchscreen display or by actuating the handsfree SmartSens infrared sensors.



Furnace chamber

The sensor is located in a corrosion-free silver furnace.



Sample preparation

Numerous useful tools are available for rapid sample preparation. They facilitate your work and ensure that sample material is optimally prepared for the measurement.

Ergonomics in Perfection we Care about You



Ergonomic design

If you insert samples manually, you can rest your hand on an ergonomically shaped support surface.



DSC



TGA



TMA



DMA



Complete thermal analysis system

A complete thermal analysis system comprises four different techniques. Each technique characterizes the sample in a particular way.

The combination of all the results simplifies interpretation. DSC measures the heat flow, TGA the weight curve, TMA the length change, and DMA the modulus.

All these measurement quantities change as a function of temperature or time.

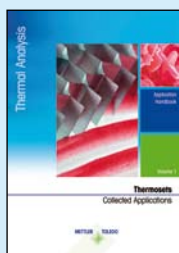

Important support services

METTLER TOLEDO prides itself in supplying outstanding instruments and the support needed for you to be successful in your field of work. Our well-trained service and sales engineers are ready and available to help you in any way possible:

- Service and maintenance
- Calibration and adjustment
- Training and application advice
- Equipment qualification

METTLER TOLEDO also provides comprehensive literature on thermal analysis applications.

Unsurpassed Performance Over the Whole Temperature Range

Measurement principles

Differential scanning calorimetry (DSC) measures the difference between the heat flows from the sample and reference sides of a sensor as a function of temperature or time.

Physics of DSC

Differences in heat flow arise when a sample absorbs or releases heat due to thermal effects such as melting, crystallization, chemical reactions, polymorphic transitions, vaporization and many other processes. Specific heat capacities and changes in heat capacity, for example during a glass transition, can also be determined from the difference in heat flow.

Robust sensor

The ceramic-coated surface protects the sensors against chemical attack and contamination. This ensures a long lifetime and constant performance properties throughout the entire temperature range.

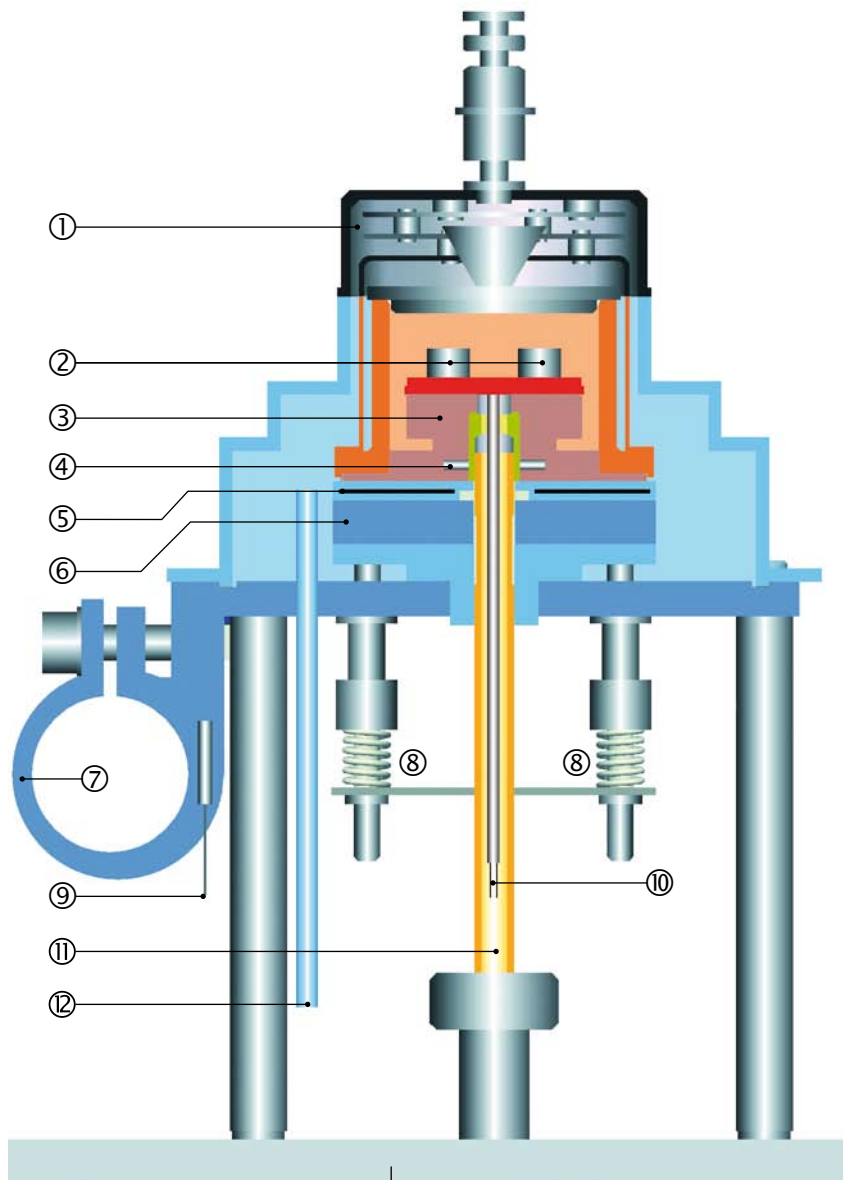

Key

- | | |
|---|------------------------------------|
| 1. Furnace lid | 7. Cooling flange |
| 2. Crucibles on the DSC sensor | 8. Compression spring construction |
| 3. Silver furnace | 9. Cooling flange PT100 |
| 4. PT100 of furnace | 10. DSC raw signal for amplifier |
| 5. Flat heater between two insulating disks | 11. Dry gas inlet |
| 6. Thermal resistance for cooler | 12. Purge gas inlet |

Reliable Automation Saves Time

The sample robot is very robust and operates reliably 24 hours a day and throughout the whole year.

Automatic and efficient

All DSC 1 models can be automated. The sample robot can process up to 34 samples even if every sample requires a different method and a different crucible.



Features and benefits:

- **Up to 34 sample positions** – dramatically increases efficiency
- **Simple and rugged design** – guarantees reliable results
- **Unique "wasp" lid piercing accessory** – hermetically sealed crucibles are automatically opened prior to measurement
- **Universal gripper** – can handle all types of METTLER TOLEDO crucibles



No sample reaction before measurement

The sample robot can remove the protective crucible lid from the crucible or pierces the lid of hermetically sealed aluminum crucibles immediately before measurement. This unique feature prevents the sample taking up or losing moisture between weighing-in and measurement. It also protects oxygen-sensitive samples from oxidation.

Modularity and Upgradeability

Unlimited Possibilities

Automatic furnace lid

The automatic furnace lid opens and closes the furnace chamber at a keystroke or when actuated by the SmartSens infrared sensors. Manual removal and replacement of the furnace lid is no longer necessary. The measurement cell is effectively isolated from the environment thanks to its optimized design with three superimposed silver lids and its heat shield.



Air cooling	RT ... 500 °C / 700 °C
Cryostat cooling	-50 °C ... 450 °C / 700 °C
IntraCoolers (several)	-35 °C ... 450 °C / 700 °C -85 °C ... 450 °C / 700 °C -100 °C ... 450 °C / 550 °C
Liquid nitrogen cooling	-150 °C ... 500 °C / 700 °C

Temperature range and cooling options

You can adapt the system to your requirements depending on the temperature range in which you want to measure.

The IntraCooler is a sealed system requiring only electrical power. It is therefore advantageous in locations where liquid nitrogen is undesirable or not available. Liquid nitrogen cooling offers greater flexibility because it allows you to measure over the entire temperature range.



Defined furnace atmosphere, programmable gas flow and gas switching

The furnace chamber can be purged with a defined gas flow. The software-controlled mass flow gas controller measures and regulates the gas flow between 0 and 200 mL/min and automatically switches up to 4 gases. Choose to regulate and switch gases such as air, nitrogen, oxygen, argon, CO₂, CO and inert hydrogen and expand your experimental possibilities.

Option → required option	FRS5	HSS7	Automatic furnace lid	SmartSens terminal	Peripeheral control	Switched line socket	Air	Cryostat	Intra Cooler	Liquid nitrogen
DSC 1 (500 °C)	•	•					•	•	•	•
DSC 1 (700 °C)	•						•	•	•	•
Sample robot (34)			essential	essential						
Automatic furnace lid				essential						
Gas controller GC 100/200				advisable						
Gas controller GC 10/20				essential	essential					
Cryostat / Intra Cooler						advisable				
Liquid nitrogen cooling					essential					

• = selectable

Innovative Accessories

Increase Measurement Power

DSC photocalorimetry

The photocalorimetry accessory for the DSC 1 allows you to characterize UV curing systems. You can study photo-induced curing reactions and measure the effects of exposure time, UV light intensity and temperature on material properties.



DSC measurements under pressure or vacuum

Determine the influence of temperature and pressure on physical transitions and chemical reactions. The high pressure DSC based on DSC 1 technology provides excellent performance at high pressures (up to 100 bar) or under vacuum (down to 10 mbar), from room temperature to 700 °C, in inert or reactive furnace atmospheres.

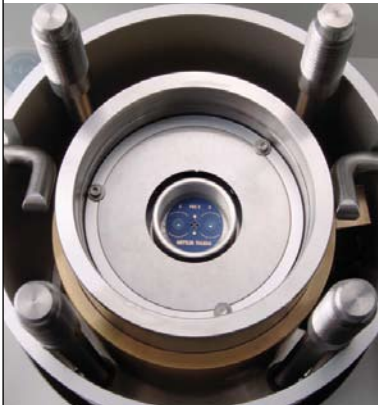

Crucible sealing press

Enormous range of crucibles

We have the right crucible for every application. The crucibles are made of different materials with volumes ranging from 20 to 900 μL and for high pressures. All the different types can be used with the sample robot.

Crucible materials available are:

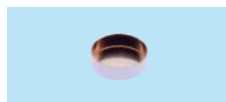

copper

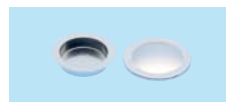

aluminum



alumina



steel (gold-plated)

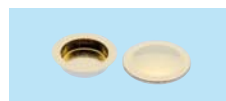

gold



platinum

Extremely Wide Application Range

Differential Scanning Calorimetry measures the enthalpies associated with transitions and reactions and the temperatures at which these processes occur. The method is used for the identification and characterization of materials.

Differential scanning calorimetry (DSC) is fast and very sensitive. Sample preparation is easy and requires only small amounts of material. The technique is ideal for quality control, material development and material research.

DSC is the method of choice to determine thermal quantities, study thermal processes, and characterize or just simply compare materials. It yields valuable information relating to processing and application conditions, quality defects, identification, stability, reactivity, chemical safety and the purity of materials.

The method is used to analyze and study polymers such as thermo-

plasts, thermosets, elastomers and adhesives, foodstuffs, pharmaceuticals, chemicals and composite materials.

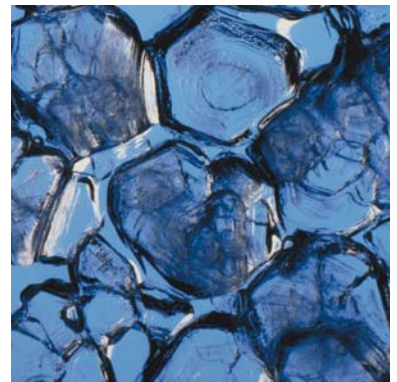
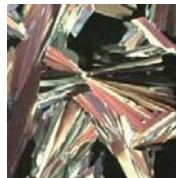

Examples of thermal events and processes that can be determined by DSC

- Melting behavior
- Crystallization and nucleation
- Polymorphism
- Liquid-crystalline transitions
- Phase diagrams and composition
- Glass transitions
- Reactivity
- Reaction kinetics
- Curing
- Stability
- Miscibility
- Effects of plasticizers
- Thermal history
- Heat capacity and heat capacity changes
- Reaction and transition enthalpies
- Purity

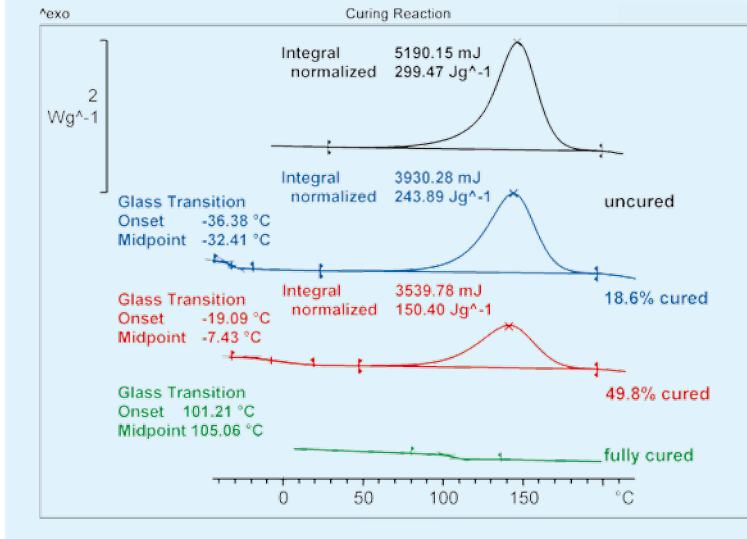

Epoxy systems

An important application of DSC is to measure the glass transition and the curing reaction in epoxy resin systems. The figure displays the curing curves of samples previously cured to different extents. The results show that as the degree of cure increases the glass transition shifts to higher temperatures and the postcuring reaction enthalpy decreases. If the reaction enthalpy of the uncured material is known (in this example, 299.5 J/g), the degree of conversion can be calculated from the enthalpy of the postcuring reaction.

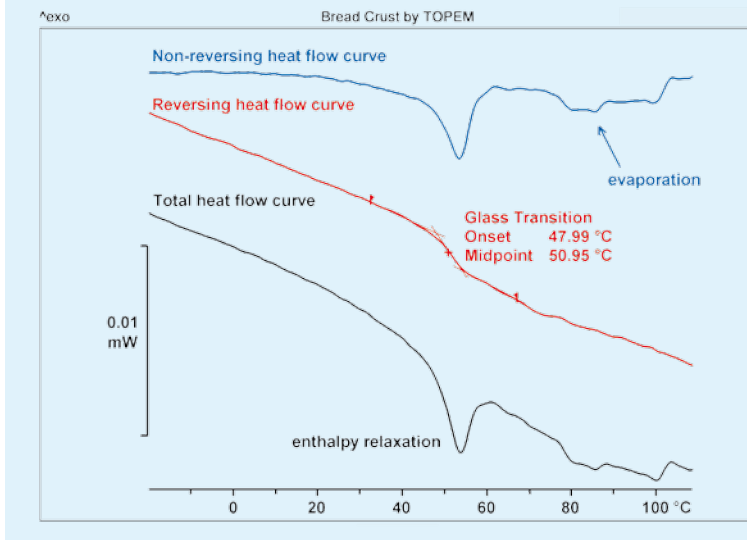

Bread crust

When complex materials are measured, different effects often overlap. The individual effects can be separated using **TOPEM**[®], a temperature-modulated DSC technique. This is demonstrated using a sample taken from a bread crust. The total heat flow curve corresponds to the conventional DSC curve and a definite assignment of the measured effects is not possible. In contrast, the reversing heat flow curve clearly shows a glass transition at 51 °C. The non-reversing heat flow curve displays the peak due to enthalpy relaxation and the evaporation of moisture from about 70 °C onward.

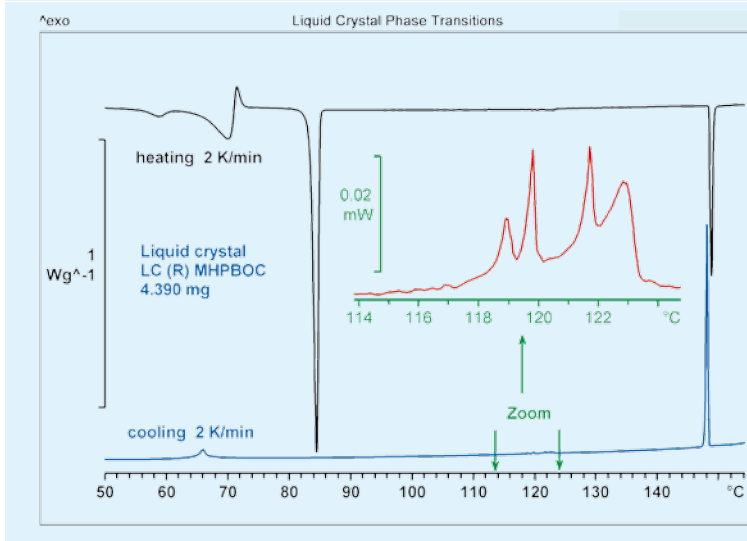
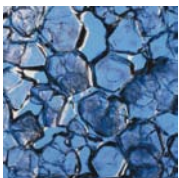

Liquid crystals

Materials consisting of relatively stiff molecules can form liquid-crystal phases. This behavior is demonstrated in the example showing DSC measurements of LC (R) MHPOBC. The substance exhibits several liquid-crystal transitions above the melting temperature at 85 °C. The transitions that occur between 114 and 124 °C are very weak and are displayed in the zoomed region of the cooling curve. Since liquid-crystal transitions often produce only very small thermal effects, the DSC used to measure such transitions must have high resolution and low noise.

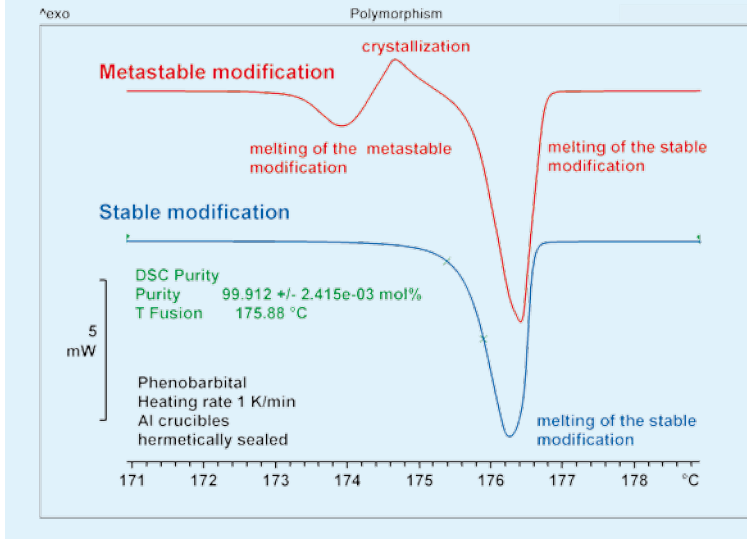
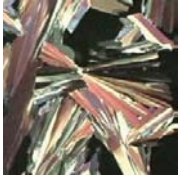

Polymorphism

The analysis of melting behavior is an important method for the quality control of pharmaceutical products. As the blue curve in the example shows, the melting curve of the stable form of phenobarbital can be used to determine the melting temperature and for purity determination.

DSC is also used to study polymorphic forms. The red curve shows that the metastable form first melts at a lower temperature. The melt then crystallizes to the stable form before this form also melts. Knowledge of the particular crystalline form present is very important for assessing the physical stability of substances.

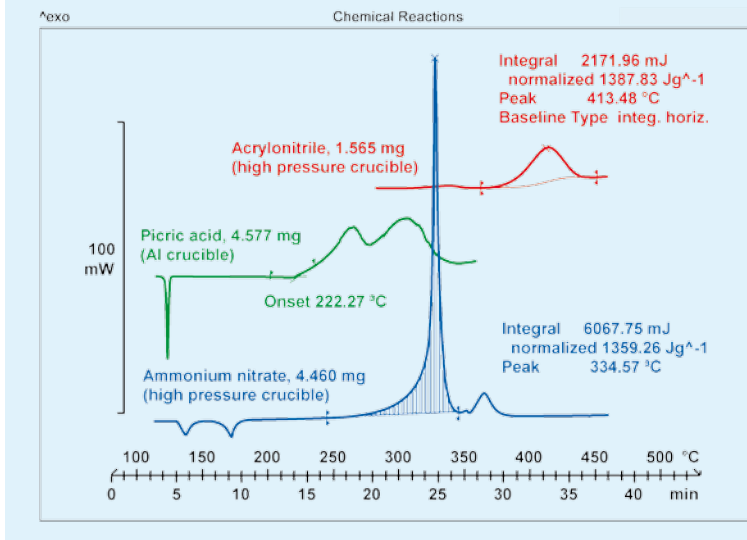

Chemical reactions

The question of reactivity plays a central role in assessing the stability of chemicals. It is important to know the reaction rate and the energy released in a reaction at a particular temperature.

Information about the decomposition reaction that can be obtained from DSC curves is very useful for safety studies, for example with autocatalytic reactions.

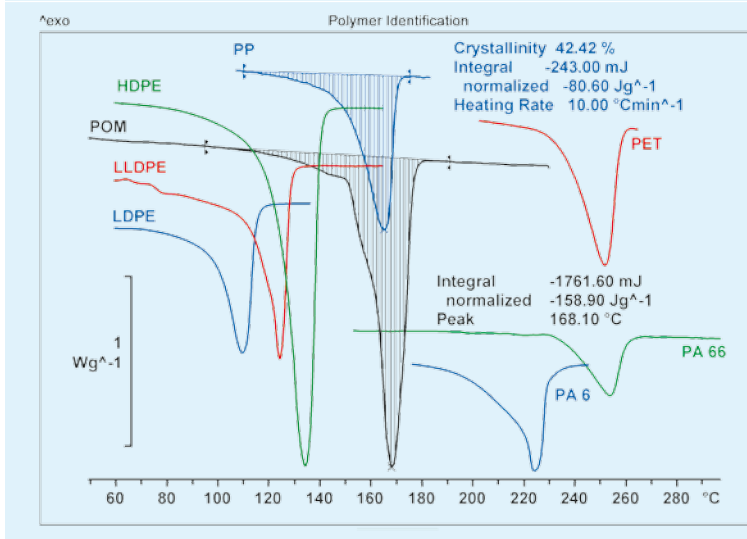

Identification of plastics

Plastics can be identified by measuring their glass transition temperatures and melting temperatures. The figure shows the melting peaks of different polymers. The peaks clearly differ in size and their position on the temperature axis. The example of PP and POM shows that identification depends both on the melting temperature and on the enthalpy of fusion. If the type of polymer is known, the degree of crystallinity can be determined from the melting peak.

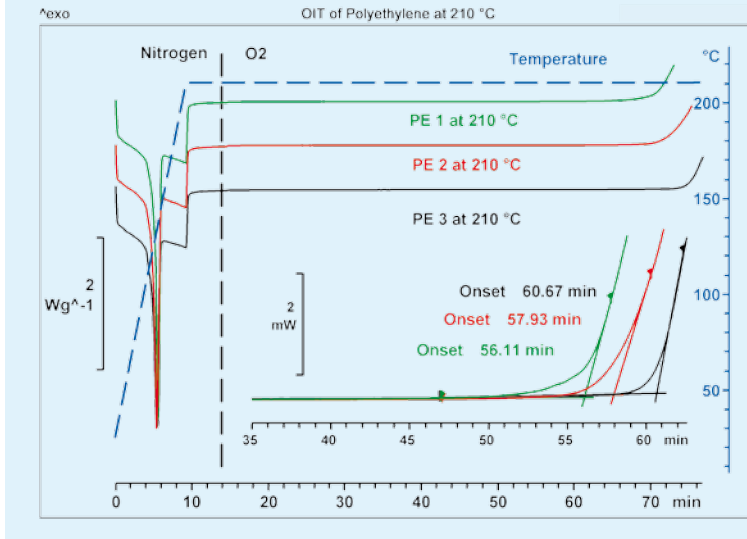

Oxidation stability

Information about the stability of materials can be obtained from the analysis of decomposition reactions. One widely used standard test method is the measurement of the oxidation induction time, OIT. This is the time up to the onset of oxidation when a sample is held isothermally at a certain temperature in an oxygen atmosphere. In the example, the OITs of three polyethylene samples stabilized to different extents were measured at 210 °C. The differences in stability toward oxidation can be clearly seen. These measurements also allow thermally, mechanically or chemically stressed material to be distinguished from fresh material.

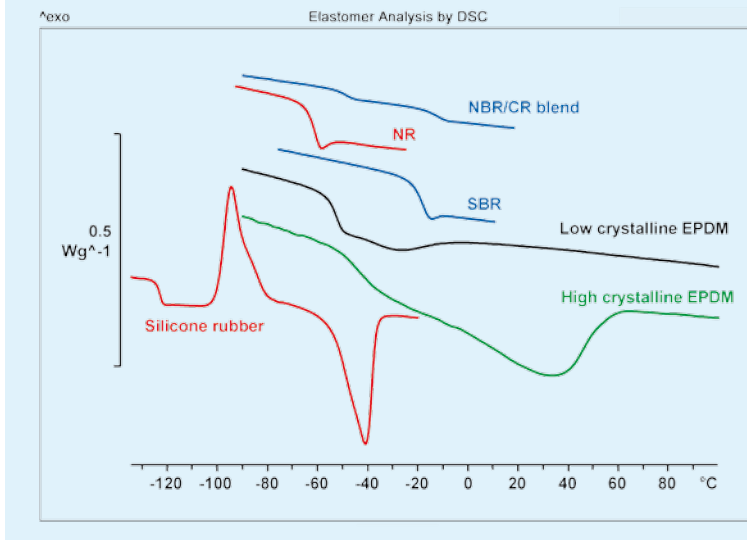

Elastomer analysis

DSC can be used to identify elastomers. The method makes use of the fact that glass transitions and melting and crystallization processes occur below room temperature. These are specific for a particular elastomer. In elastomer analysis, DSC is an important complementary technique to thermogravimetric analysis (TGA).

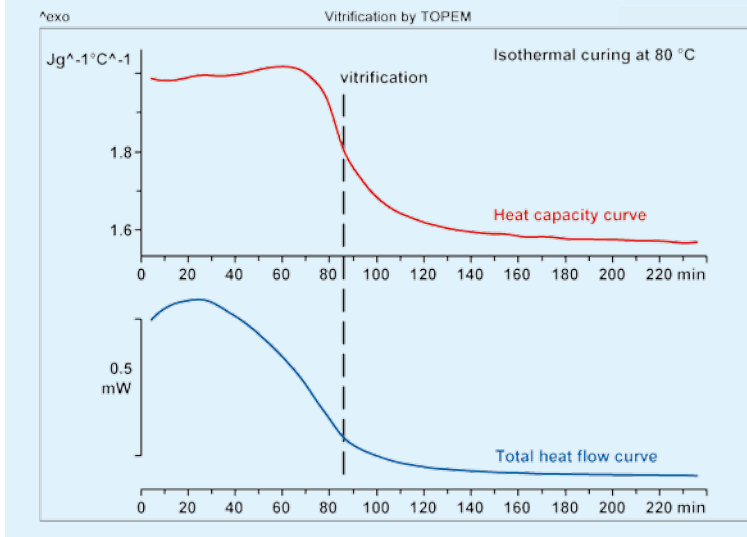

Curing of adhesives

When an adhesive cures isothermally, the material changes from a liquid to a solid as a result of a chemical reaction. An amorphous polymeric glass is formed and the reaction practically stops. This process is known as vitrification and is of great practical importance because a vitrified adhesive is not fully cured and is therefore unstable. The properties of the material gradually change over a long period of time. The example shows that measurement of the heat capacity during the curing reaction using **TOPEM**[®] (a temperature-modulated DSC technique) is a simple and reliable method to identify vitrification processes.

DSC 1 Specifications

Temperature data			
Temperature range	air cooling	RT ... 500 °C (200 W)	RT ... 700 °C (400 W)
	cryostat cooling	-50 °C ... 450 °C	-50 °C ... 700 °C
	IntraCooler	-100 °C ... 450 °C	-100 °C ... 550 °C
	liquid nitrogen cooling	-150 °C ... 500 °C	-150 °C ... 700 °C
Temperature accuracy ¹⁾		± 0.2 K	
Temperature precision ¹⁾		± 0.02 K	
Furnace temperature resolution		± 0.00006 K	
Heating rate ²⁾ RT ... 700 °C		0.02 K ... 300 K/min	
Cooling rate ²⁾		0.02 K ... 50 K/min	
Cooling time	air cooling	8 min (500 °C ... 100 °C)	9 min (700 °C ... 100 °C)
	cryostat cooling	5 min (100 °C ... 0 °C)	
	IntraCooler	5 min (100 °C ... 0 °C)	
	liquid nitrogen cooling	15 min (100 °C ... -100 °C)	

Calorimetric data			
Sensor type		FRS5	HSS7
Sensor material		Ceramic	
Number of thermocouples		56	120
Signal time constant		1.7 s	3.9 s
Indium peak (height to width)		17	6.9
TAWN	resolution	0.12	0.30
	sensitivity	11.9	56.5
Measurement range	at 100 °C	± 350 mW	± 160 mW
	at 700 °C (FRS5)	± 200 mW	
	at 500 °C (HSS7)		± 140 mW
Resolution		0.04 µW	0.01 µW
Digital resolution		16.8 million points	

Sampling	
Sampling rate	maximum 50 values/second

Special modes	
Automation	optional
IsoStep®	
ADSC ³⁾	
TOPEM®	
Photocalorimetry	

Approvals
IEC/EN61010-1:2001, IEC/EN61010-2-010:2003
CAN/CSA C22.2 No. 61010-1-04
UL Std No. 61010A-1
EN61326-1:2006 (class B)
EN61326-1:2006 (Industrial environments)
FCC, Part 15, class A
AS/NZS CISPR 22, AS/NZS 61000.4.3
Conformity mark: CE

¹⁾ based on metal standards

²⁾ depends on instrument configuration

³⁾ not available in USA and Japan

www.mt.com

For more information

Mettler-Toledo AG, Analytical
 CH-8603 Schwerzenbach, Switzerland
 Phone +41-44-806 77 11
 Fax +41-44-806 73 50
 Internet: www.mt.com

Subject to technical changes
 © 07/2007 Mettler-Toledo AG
 Printed in Switzerland, ME-51724556
 MarCom Analytical



Quality certificate. Development, production and testing according to ISO 9001.



Environmental management system according to ISO 14001.



European conformity. The CE conformity mark provides you with the assurance that our products comply with the most recent EU directives.