

Agilent 3396 Series III Integrator

Reference Manual



Agilent Technologies

Agilent 3395/3396 Integrators

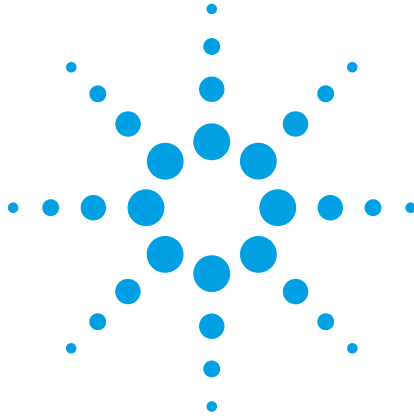

Manuals

These manuals may contain references to HP or Hewlett-Packard. Please note that Hewlett-Packard's former test and measurement, semiconductor products and chemicals analysis businesses are now part of Agilent Technologies. The HP 3395/3396 Integrator referred to throughout this document is now the Agilent 3395/3396 Integrator.



Agilent Technologies

Printing History

The information contained in this document may be revised without notice.

Hewlett-Packard makes no warranty of any kind with regard to this material, including, but not limited to, the implied warranties of merchantability and fitness for a particular purpose. Hewlett-Packard shall not be liable for errors contained herein or for incidental or consequential damages in connection with the furnishing, performance, or use of this material.

No part of this document may be photocopied, reproduced, or translated to another program language without the prior written consent of Hewlett-Packard Company.

HP part number
03396–90550

First edition—January 1995
Second Edition —August 1997
Printed in USA

**©Copyright 1990—1997 by Hewlett-Packard Company
All Rights Reserved. Reproduction, adaptation, or translation without prior
written permission is prohibited, except as allowed under the copyright laws.**

Safety Information

The 3396 meets the following IEC (International Electrotechnical Commission) classifications: Safety Class 1, Transient Overvoltage Category II, and Pollution Degree 2.

The unit has been designed and tested in accordance with recognized safety standards and designed for use indoors. If the instrument is used in a manner not specified by the manufacturer, the protection provided by the instrument may be impaired. Whenever the safety protection of the unit has been compromised, disconnect the unit from all power sources and secure the unit against unintended operation.

Refer servicing to qualified service personnel. Substituting parts or performing any unauthorized modification to the instrument may result in a safety hazard. Disconnect the AC power cord before removing covers.

Safety Symbols

Warnings in the manual or on the instrument must be observed during all phases of operation, service, and repair of this instrument. Failure to comply with these precautions violates safety standards of design and the intended use of the instrument. Hewlett-Packard Company assumes no liability for the customer's failure to comply with these requirements.

WARNING

A WARNING CALLS ATTENTION TO A CONDITION OR POSSIBLE SITUATION THAT COULD CAUSE INJURY TO THE USER.

Caution

A Caution calls attention to a condition or possible situation that could damage or destroy the product or the user's work.



Caution. Refer to accompanying documents.



Indicates hazardous voltages.



Indicates earth (ground) terminal.

Important User Information for In Vitro Diagnostic Applications

This is a multipurpose product that may be used for qualitative or quantitative analyses in many applications. If used in conjunction with proven procedures (methodology) by a qualified operator, one of these applications may be in vitro diagnostic procedures.

General instrument performance characteristics and instructions are included in this manual. Specific in vitro diagnostic procedures and methodology remain the choice and the responsibility of the user and are not included.

Sound Emission Certification for Federal Republic of Germany

Manufacturer's Declaration

Sound Emission: This information is provided to comply with the requirements of the German Sound Emission Directive dated January 18, 1991.

- Sound Pressure $L_p < 55$ dB(A)
- At Operator Position
- Normal Operation
- According to ISO 7779 (Type Test)

Herstellerbescheinigung

Der Deutschen Bundespost wurde das Inverkehrbringen dieses Gerätes/Systems angezeigt und die Berechtigung zur Überprüfung der Serie auf Einhaltung der Bestimmungen eingeräumt.

Schallemission: Diese Information steht im Zusammenhang mit den Anforderungen der Maschinenlärminformationsverordnung vom 18 Januar 1991.

- Schalldruckpegel $L_p < 55$ dB(A)
- Am Arbeitsplatz
- Normaler Betrieb
- Nach DIN 45635 T. 19 (Typprüfung)

Contents

1 Preinstallation Checklists

- Site Requirements 1–2
- Unpacking and Inspecting Your Unit 1–3
- Recording Important Numbers 1–4

2 Installing the Integrator

- Installing Paper Assemblies 2–4
 - Installing the Roll Paper Mechanism 2–4
 - Installing the Z-Fold Paper Mechanism 2–6
 - Installing the Paper Separator 2–7
- Installing Print Cartridges 2–8
 - Installing the Blotter Pad 2–9
 - Priming the Print Cartridge 2–10
 - Inserting the Print Cartridge 2–11
- Loading Paper 2–12
- Applying Power and Running the Self-Test 2–13
 - Verifying the Voltage Setting 2–14
 - Initial Turn On 2–15
 - Setting Paper Parameters 2–17
 - Setting the Date and Time 2–19
- Installing Expansion Cards 2–20

3 Cable Connections

- Connecting HP-IL Devices 3–2
 - Installing HP-IL and INET Devices 3–5
 - Installing the HP 19405B INTEG Event Control Module (IECM) 3–6
 - Installing an HP-IB Disk Drive 3–7
 - Loop Power-Up 3–8
- Installing Signal Cables 3–9
 - Connections to Hewlett-Packard Analytical Instruments 3–10
 - Connections to Non-Hewlett-Packard Analytical Instruments 3–11
- Installing Sample/Remote Devices 3–12

- Installing the Sample Number (BCD) Cable 3–13
- Connecting a Remote Control Cable to
Hewlett-Packard Equipment 3–14
- Connecting a Remote Control Cable to
Non-Hewlett-Packard Units 3–14
- Connecting RS-232-C Cables 3–17

4 Routine Maintenance

- Exterior Cleaning 4–2
- Removing/Reloading Paper 4–3
 - Removing Paper from the Printer 4–3
 - Reloading Paper 4–3
- Maintaining the Printer 4–5
 - Replacing the Blotter Pad 4–5
 - Checking the Print Cartridge 4–6
 - Cleaning the Carriage Contacts 4–7

5 Obtaining HP Service

- Filling out the Repair Information Form 5–2
- Returning Your HP 3396 for Repair 5–5
- Repacking Your Unit for Shipment 5–6
- HP Service 5–7

6 Troubleshooting

- Power Problems 6–2
 - No Response at Initial Turn On
(Unit does not function) 6–2
 - Checking the Fuse 6–3
 - “Power failed” Messages Appear After Working 6–4
 - COMM Indicator Light Blinks After
Initial Turn On Tests Are Complete 6–4
- Signal Problems 6–5
 - Data Represents a Zero or Straight
Baseline with INET Instruments 6–5
 - Data Represents a Zero or Straight Baseline,
or is Pinned at Maximum Value with Analog Signal 6–6

- Excessive Noise or Drift on Chromatogram 6–7
- Reported, Processed, or Raw Data
 - Are Not What You Expected 6–8
- System Problems 6–9
 - Integrator Cannot Be Started or Stopped
 - from an External Device 6–9
 - HP 3396 Does Not Start or Stop an External Device 6–10
 - HP 3396 Does Not Communicate with RS-232-C Device 6–11
 - “LOOP DOWN” Message Printed 6–12
 - External Sample Number is Missing or Inaccurate 6–13
- Running the Automatic Power-On Tests 6–14

7 Diagnostics

- Purpose of This Section 7–2
- Safety Information 7–2
- Running the Self-Test Diagnostics 7–3
- Description of Self-Test Diagnostics 7–6
- Running the Signal Tests 7–15
 - The SSET ANALOG Command 7–15
- Zero-Volt Input Test 7–17
- One-Volt Input Test 7–18
- Diagnostic Procedures 7–19
 - Measuring dc Supply Voltages 7–19
 - Measuring Motor Windings 7–23
 - Partitioning Failures 7–25
 - Module Level Troubleshooting 7–25
 - Interpreting Diagnostic Test Failures 7–30
 - Remote and Sample Number Test 7–31
 - RS-232-C Cable Testing 7–32
- Disassembly and Reassembly Instructions 7–34
 - Remove Power from the Unit 7–34
 - Remove the Paper 7–34
 - Remove the Paper Hangers (if Installed) 7–34
 - Remove the Printer Window 7–35
 - Remove the Paper Separator 7–35

- Remove the Keyboard 7–35
- Remove the Top Cover 7–35
- Remove the Print Mechanism 7–37
- Remove the Power Supply Board 7–39
- Remove the Line Module 7–40
- Remove the Cooling Fan 7–40
- Remove the Main Board 7–41

8 Parts and Cables

- Replacement Parts 8–2
- Cables for Obsolete HP Instruments 8–4
- Cable Diagrams 8–5
 - Analog Signal Cables 8–5
 - Remote Control Cables 8–8
 - Sample Number Cable 8–18
 - RS-232-C Cables 8–21
- Power Cable 8–24

9 Communicating with Other Devices

- What Devices Communicate with the Integrator? 9–2
- Using Non-INET Analytical Instruments 9–3
 - Using the Remote Control Cable 9–3
 - Using the Sample Number Cable 9–4

10 Using the Instrument Network

- What is the Instrument Network? 10–2
- Starting and Stopping INET 10–3
- Checking for Instrument Readiness 10–5
- Listing INET Devices 10–6
- Controlling INET Instruments with the HP 3396 10–9
 - Controlling the HP 5890 through BASIC 10–13
 - Controlling the HP 7673 through BASIC 10–14
- Controlling the HP 6890 10–16
- Understanding INET 10–17
 - Controlling INET Devices 10–18
 - INET Operating States 10–20

- Automatic Network Configuration 10–21
- Establishing and Changing INET Data Paths 10–24
- INET Data Types 10–24
- Changing the INET Configuration Table 10–29
- Run and Report Annotation Data (A0 AND R0) 10–32
- B0 Data (B0) 10–33
- Chromatographic Data (C1) 10–34
- Immediate Data (I0 AND I1) 10–34
- Device Dependent Commands (K0) 10–36
- Sample Data (S0) 10–36
- HP 3396 Background Tasks 10–38

11 Using Disk Drives

- Compatible Disk Drives 11–2
 - Listing Devices on the Loop 11–3
 - Autoconfiguration and Reconfiguration 11–4
- Using Disk Drives 11–7
 - Accessing Disk Drives 11–7
 - File System Commands 11–9
- Understanding HP-IL and HP-IB 11–12
 - How HP-IL Operates 11–13

12 Using RS-232-C Devices

- What is the RS-232-C Interface? 12–2
- Installing RS-232-C Devices 12–3
- Choosing the Proper Cable 12–4
 - DTE or DCE? 12–5
 - Customizing Cables 12–7
- Connecting the Cable 12–8
- The RS-232 Configuration Settings 12–9
- Changing the RS-232 settings with the SSET RS232 command 12–10
 - The RS-232 Configuration Switches 12–10
 - Changing the Default RS-232 Configuration Switches 12–10
 - Changing the RS232 settings with the SSET RS232 command 12–11

- Listing the Switch Settings 12–12
- Data Rate Switches 1, 2, 3 12–12
- Hardware Handshake Switch 4 12–13
- Switches 5, 6, 7, and 8 are not used 12–14
- Handshake Delay Switch 9 12–14
- Timeout Duration Switch 10 12–14
- Matching RS-232-C Protocol 12–15
- Using External BASIC 12–17
- Using RS-232-C in Remote Mode 12–18

Appendix A

- Standard Features A–1
 - Data Storage A–1
 - Calculations and Reporting A–2
 - Printer/Plotter Characteristics A–3
 - External Control and Data Communications A–4
 - EPROM-Based Programs A–4
- Specifications A–5
 - Data Acquisition A–5
 - Electrical: A–6
 - Physical Characteristics: A–6
 - Environmental Conditions: A–6

Appendix B

- Storing Your Integrator B–1

Appendix C

- Dual Channel INET_CONTROL Commands C–1
- Buffer Signal Assignment C–3
 - Default Assignment Scheme C–3
- Setting HP 3396 / HP GC Data Paths C–5

1

Site Requirements 1–2

Unpacking and Inspecting Your Unit 1–3

Recording Important Numbers 1–4

Preinstallation Checklists

Preinstallation Checklists

Site Requirements

The HP 3396 Series III Integrator is designed for laboratory use. Ensure that the intended operating environment for your integrator meets these requirements:

- The atmosphere is free of corrosive chemicals.
- The temperature remains between 5° and 40°C (41° to 104°F) while the unit is operating.
- An altitude up to 2000 m.
- The relative humidity is between 10 and 90% noncondensing.
- A surface area about 46 cm wide by 46 cm deep (about 18 by 18 inches) exists for the unit, and about 46 cm (18 inches) exists above the unit.
- The power line meets the following specifications:

Line voltages: 115 or 230 V ac (+15 to -22%)

Line frequency: 48 to 66 Hz

(The HP 3396 Series III consumes a maximum of 50 VA.)

Refer to Appendix A for complete HP 3396 Series III specifications.

Unpacking and Inspecting Your Unit

- Verify that you have received all shipped containers by checking the carrier's papers.
- Inspect the exterior of the shipping container(s) for physical damage and watermarks. If damage or water is indicated, immediately contact your carrier (retain the carton and all packing materials for the carrier's inspection).
- Open the integrator box; remove the manual set and miscellaneous components from inside the container and set all of these aside.
- Unpack the HP 3396 Series III Integrator and inspect it for damage. If you detect damage, contact your nearest Hewlett-Packard Sales and Service Office.
- Unpack any other containers.

Recording Important Numbers

In any verbal or written correspondence with Hewlett-Packard concerning your integrator, you will need to know the following information:

Instrument Model Number:

HP 3396C

Instrument Name:

HP 3396 or Series III Integrator

Instrument Serial Number:

Take a few minutes now to fill in the empty box above. The instrument's serial number can be found on the rear of the integrator.

Installing Paper Assemblies	2-4
Installing Print Cartridges	2-8
Loading Paper	2-12
Applying Power and Running the Self-Test	2-13
Installing Expansion Cards	2-20

Installing the Integrator

Installing the Integrator

Before installing the paper assemblies, print cartridge, or loading paper, open the printer window.

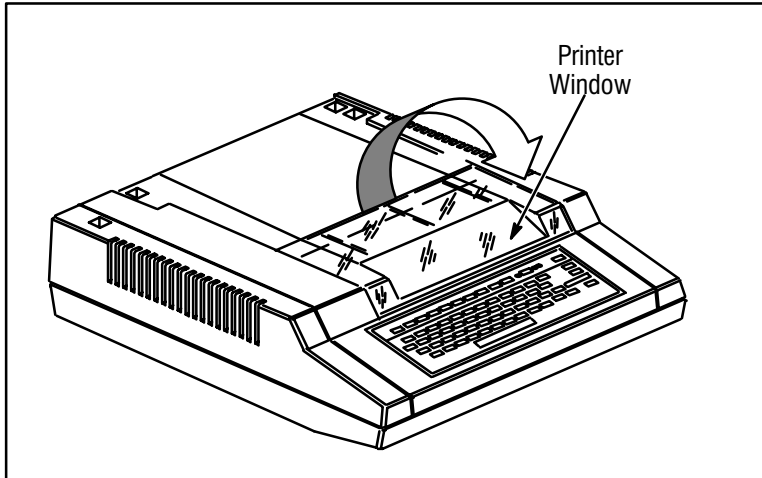

Figure 2-1. The Printer Window

The printer window is opened by lifting its rear edge upward and forward toward the front of the integrator.

Installing the Integrator
Applying Power and Running the Self-Test

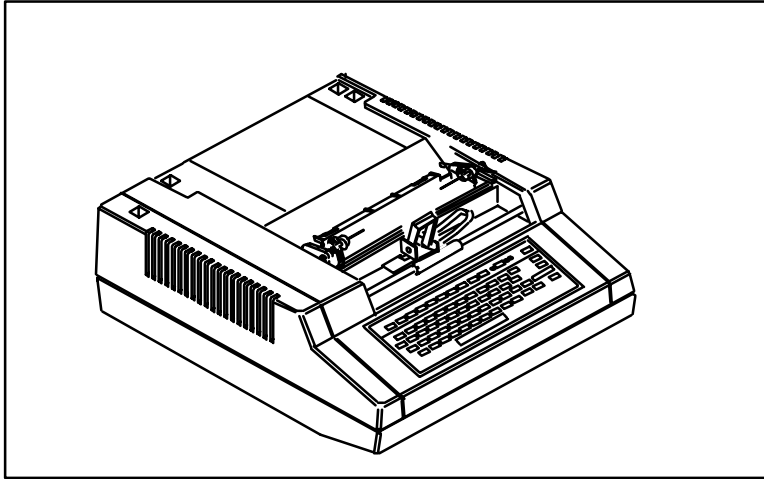

Figure 2-2. The Window Open

The window can, if necessary, be removed completely. Squeeze the two hinged ends, disengaging one end from its axis tab, and then lift the window away from the integrator.

Installing Paper Assemblies

Two forms of dispensing paper are available for the HP 3396 Integrator: the standard roll of paper, which has its assembly supplied in all units, and the z-fold paper, which can be ordered as an option.

To maintain the high reliability of the printer mechanism, use only the recommended paper and print cartridges listed in chapter 8 of this manual.

Installing the Roll Paper Mechanism

From the integrator package, remove:

- 2 paper-roll holder brackets
- 1 paper-roll rod
- 1 roll of inkjet paper

You may also want to remove the paper separator at this time, for installation later.

Installing the Integrator
Applying Power and Running the Self-Test

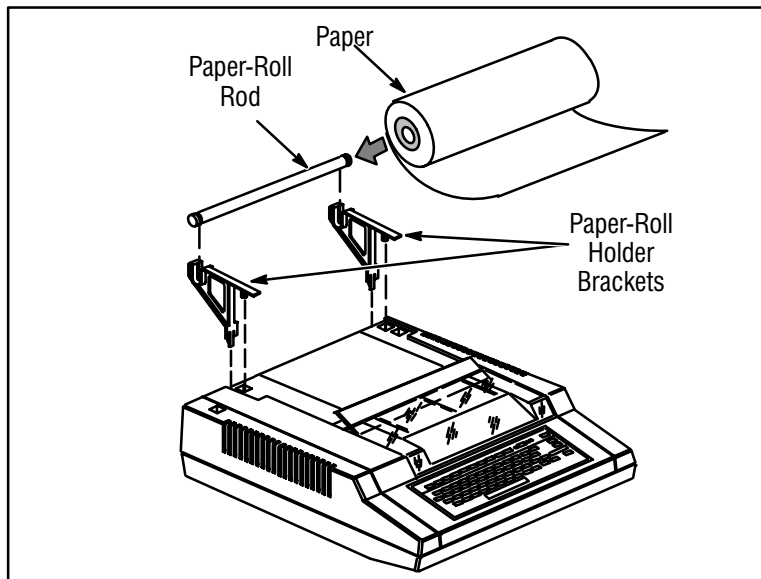

Figure 2-3. Roll Paper Mechanism

Snap the two paper-roll holder brackets into the appropriate slots on the top rear of the integrator.

Unwrap the roll of paper. Check that the edges of the roll are flat and even, and that no slack exists in the roll.

Insert the paper-roll rod through the paper roll.

Position the roll of paper so that it unrolls from beneath the roll, towards the front of the unit (see Figure 2-3). Mount the rod and paper on the brackets.

Installing the Z-Fold Paper Mechanism

From the accessory package, remove:

- 1 pack of z-fold paper
- 1 paper stand

You may also want to remove the paper separator from the integrator package at this time, for installation later.

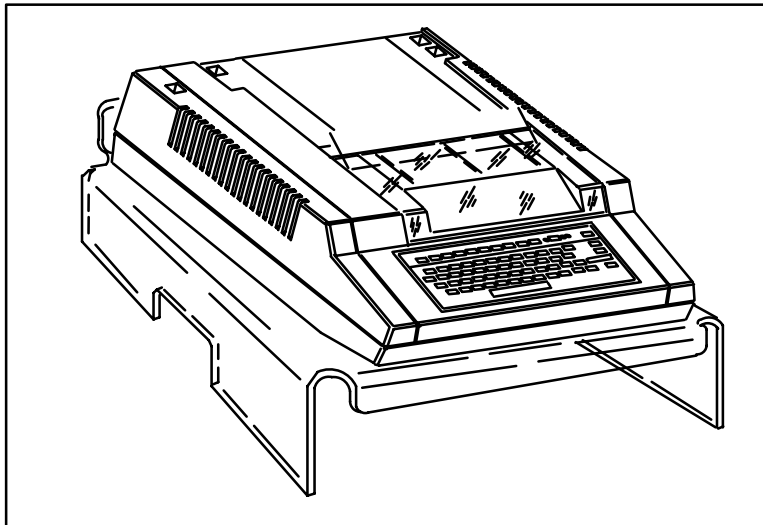

Figure 2-4. Z-Fold Paper Stand

Unwrap the pack of paper.

Lay the top sheet of paper (with the “PRINT THIS SIDE” facing *down*) on flat top surface of the integrator.

Position the pack of paper inside the stand so that it unfolds from the top of the pack and around the rear of the integrator and stand.

The pack of paper will have to temporarily be moved later when connecting cables. However, doing this now will assure proper paper loading.

Installing the Paper Separator

The paper separator is used with both the roll paper and the z-fold paper.

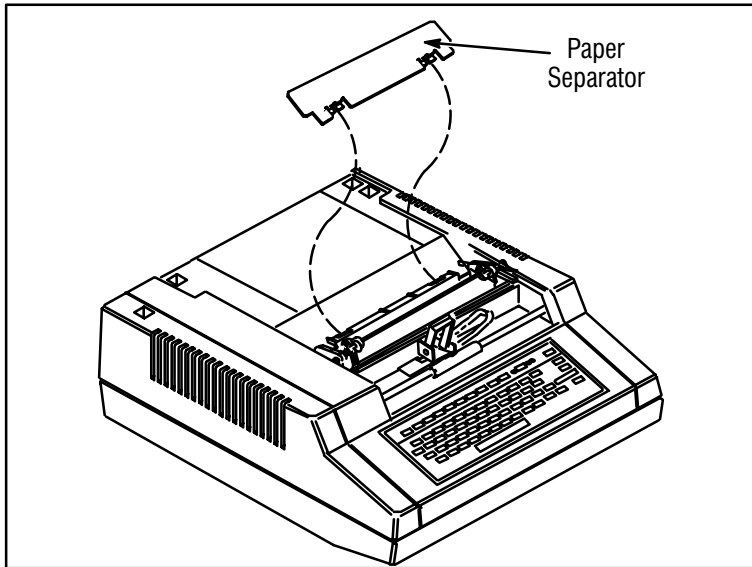

Figure 2-5. Installing the Paper Separator

Insert the tabs at the bottom of the separator into the slots in the printer mechanism.

Installing Print Cartridges

Check the expiration date stamped on the bottom of the print cartridge container. Be certain that the expiration date has not yet been reached.

WARNING

**THE INK IN THE PRINTHEAD CARTRIDGE CONTAINS
DIETHYLENE GLYCOL, WHICH IS HARMFUL IF SWALLOWED.
KEEP NEW OR USED CARTRIDGES OUT OF REACH OF CHILDREN.**

If the printer window is not already open, open it now.

Remove the print cartridge and the blotter from the container, taking care not to touch the face of the cartridge. (The blotter is stored under the clear plastic disk at the bottom of the container.)

Installing the Blotter Pad

When you turn on the integrator, ink is sprayed on the blotter to clear the printhead. Blotters are provided with each print cartridge and should be replaced each time the cartridge is replaced.

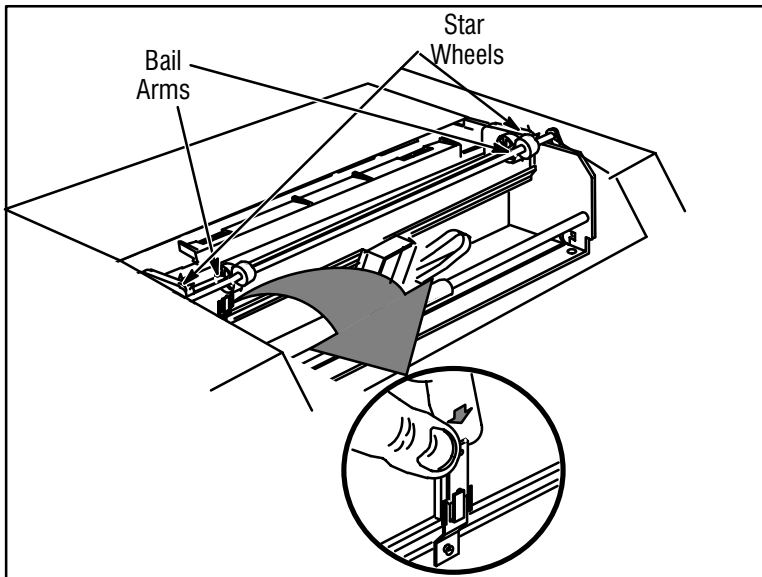

Figure 2-6. Inserting Blotter Pad

Insert the blotter into the holder as shown below, making sure that the stiff-coated side of the blotter faces the back of the printer.

Priming the Print Cartridge

Prime the print cartridge by gently pushing the end of a straightened paper clip or similar object about 1/4-inch (6 mm) into the hole in the rear of the print cartridge.

Caution

Be careful. Excessive force will puncture the bladder!

Gently push the ink bladder until a drop of ink appears on the face of the cartridge.

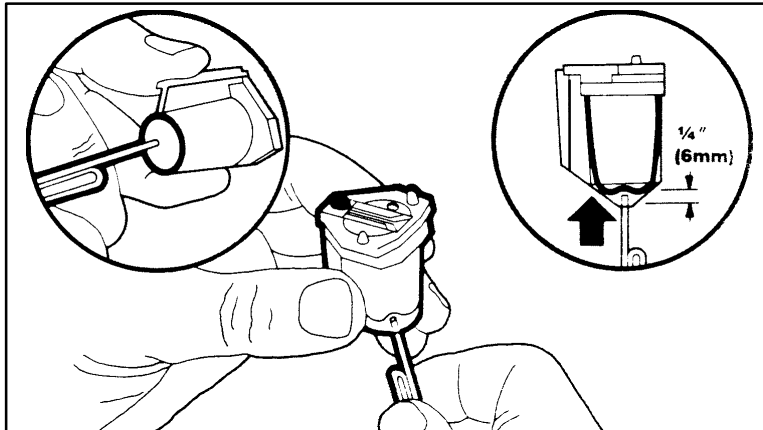

Figure 2-7. Priming the Print Cartridge

Wipe the print cartridge face with a soft cloth or lint-free tissue.

Inserting the Print Cartridge

Pull the carriage cradle latch all the way down, as shown in circle 1 of the figure below.

Set the print cartridge in the cradle (the action labelled 2 below).

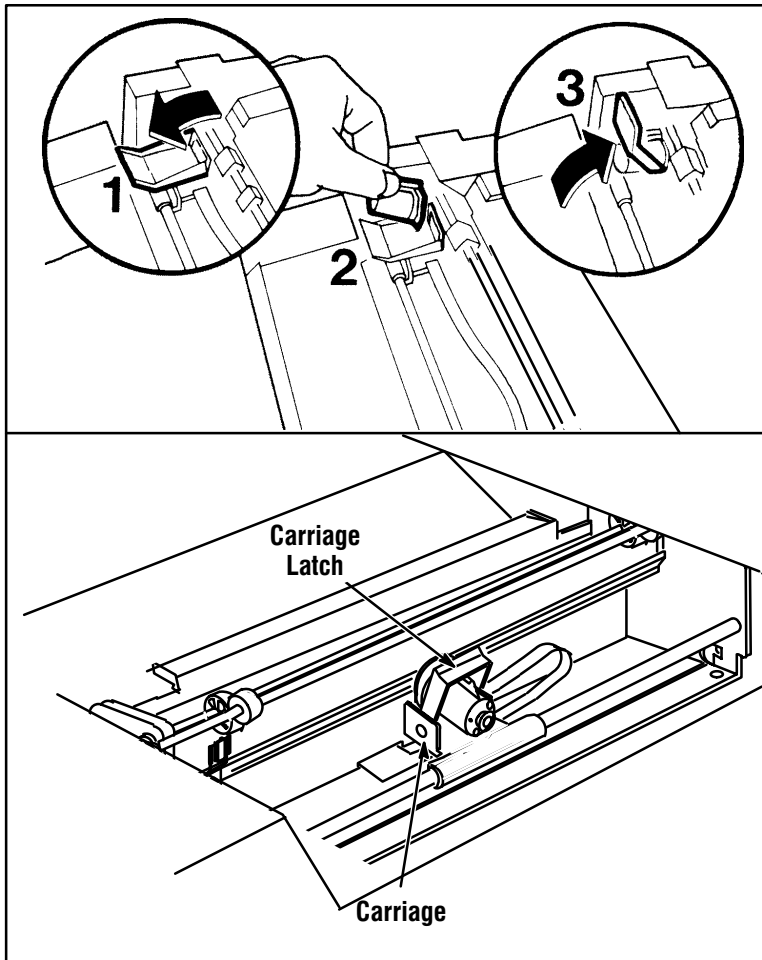

Figure 2-8. Inserting the Print Cartridge

Push the cradle latch up to lock the print cartridge in place (as shown in circle 3).

Loading Paper

The paper should be positioned on the top flat surface of the integrator with the PRINT THIS SIDE facing down against the surface. After rotating around the roller, the PRINT THIS SIDE will be correctly facing up.

Pull both bail arms forward to their open positions.

Slide the paper into the slot under the paper separator. (It may be helpful to pull the paper separator forward temporarily until the paper is inserted.)

Push the paper under the roller until its edge passes above the bail arms.

Align the holes in the left edge of the paper with the sprockets of the left pin wheel.

If necessary, adjust the right pin wheel to the width of the paper. It can move sideways to accommodate for minor differences in paper widths. Align the holes in the right side of the paper with the sprockets of the right pin wheel.

Be certain that the paper is straight and that both sides are even.

Push the bail arms back to their closed positions, locking the paper in position against the roller.

Close the printer window.

Verify that the paper's PRINT THIS SIDE is correctly positioned on the side of the paper toward the print cartridge.

Applying Power and Running the Self-Test

If other instruments are to be connected to the HP 3396, see their installation instructions before attempting to apply power to the integrator.

WARNING

THE POWER CORD MUST BE CONNECTED ONLY TO A LINE POWER SOURCE WITH A PROTECTIVE EARTH CONTACT. DO NOT USE AN EXTENSION CORD, POWER CABLE, OR PLUG ADAPTER WITHOUT A PROTECTIVE EARTH (GROUNDING) CONDUCTOR. PROPER GROUNDING SHOULD BE VERIFIED.

First, ensure that voltage shown on the line voltage selection switch at the rear of the instrument matches the intended power source.

Verifying the Voltage Setting

Locate the line voltage selection switch on the rear panel of the integrator above the power cord receptacle.

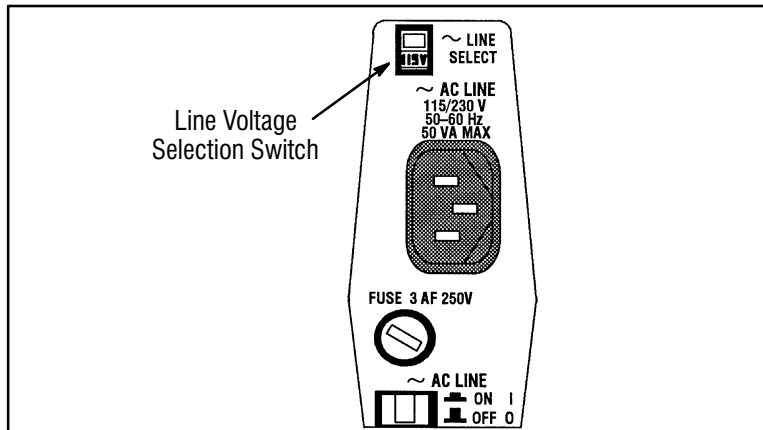

Figure 2-9. Line Voltage Selection

A voltage setting of 115 is compatible with sources from 90 to 132V.

A voltage setting of 230 is compatible with sources from 180 to 264V.

Make sure the selected operating voltage matches the voltage of the power source you're using. If it doesn't match, do not apply power! Set the proper voltage. If you cannot, contact your local HP office.

Initial Turn On

Connect the power cable **first** to the integrator and **second** to a properly grounded power source of the same voltage.

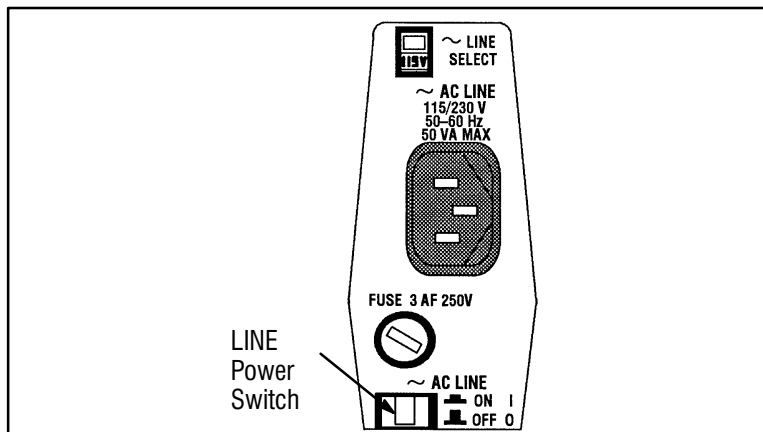

Figure 2-10. Line Voltage Selection

Press the LINE power switch on the rear panel of the integrator. The symbol “0” indicates off. The symbol “|” indicates on.

The integrator will perform a warm-start power-on when power is first applied. Operating parameters and the memory disk M: are preserved.

A cold-start is invoked by simultaneously pressing the [CTRL] and [DEL] keys. The operating parameters are restored to their default values and the information stored on the memory disk M: are lost during a cold-start. The integrator also performs a series of self-tests during a cold-start. When the integrator has successfully passed the self-tests (after about 30 seconds), the firmware revision numbers (Z80/HOST/INET/PP) and the installed applications programs are printed.

```
!"#$%&'<>*+,-./0123456789:;<=>?@ABCDEFGHIJKLMNORSTUUVWXYZ[\]^_`abode  
fghijklmnopqrstuvwxyz{|}~9:;<=>?@ABCDEFGHIJKLMNORSTUUVWXYZ[\]^_`abode  
-----  
Performing self test: unit will  
accept commands when KEYBD led is ON  
  
Model 3396B PLUS BASIC, Rev B.00.05 3/16/90  
Z80/HOST/INET/PP Rev = m/B/m/1
```

Figure 2-12. Power-On Salutation

When BASIC language programming capability is installed, the integrator prints a “PLUS BASIC” message.

When HP-IL or INET devices are connected, the integrator prints a “LOOP UP” message, if all the devices on the loop are powered-on and working.

Setting Paper Parameters

Unless set differently, the initial physical position of the paper is assumed to be the correct the top of form (TOF). Moreover, it is also assumed that US letter size paper is being used.

To set or reset the top of form (TOF) and specify either of the two size pages:

- the U.S. 8.5 x 11 inch letter size (66 lines)
- the ISO 297 mm A4 size (72 lines)

Press **[CTRL] [K]**

Defines top of form (TOF) and a 66-line, 11-inch page length.

Press **[CTRL] [V]**

Defines top of form (TOF) and a 72-line, A4-page length.

To simply advance the paper one full page:

Press **[CTRL] [L]**

Advances the paper to the next top of form location, using the page length defined by either of the two preceding commands.

To advance the paper less than a full page:

Press **[ENTER]**

*Advances the paper one line and prints out an * with each carriage return.*

Press **[SHIFT] [ENTER]**

Advances the paper as long as you hold the keys down.

Press **[CTRL] [A]**

Advances the paper one-eighth of a line. This is useful when positioning the paper before setting top of form.

Creating the Little Falls Look
Using this document as an Interleaf template

To set form feed and perforation skipping options:

Press **[OP()] [5] [ENTER]**

Most of the items in this dialog concern the report and the information to be included in it. Such items are discussed fully in the Operating Manual.

* OP # 5

PRINT & POST-RUN LIST OPTIONS

Large font [Y*/N]:
Store post-run report [Y/N*]:
External post-run report [Y/N*]:
List run parameters [Y/N*]:
List timetable [Y/N*]:
List calibration [Y/N*]:
List remote method [Y/N*]:

Form-feed before report [Y/N*]: **Y [ENTER]**
Form-feed after report [Y/N*]: **Y [ENTER]**
Skip perforations in report [Y/N*]: **Y [ENTER]**
Skip perforations in plot [Y/N*]: **Y [ENTER]**

The last four items control paper feed during the plot and report.

The two form feed options cause an advance to the next top-of-page before and/or after printing a report.

Skipping perforations in the plot may only be selected when perforation skipping in the report is also selected.

For more information about how to use this option, refer to the Operating Manual.

Setting the Date and Time

The HP 3396 Integrator contains a calendar and clock, which can be used to label reports and to “time stamp” files.

To list time only:

Type **[T] [I]** and press **[ENTER]**

To list the date and time:

Type **[D] [A]** and press **[ENTER]**

The clock does not run when the integrator is off. Every time you start the integrator you need to reset the date and time.

To set the calendar:

Type **[D] [A] mm/dd/yy [ENTER]**

where mm/dd/yy is the...

month	(mm = 01 to 12)
day	(dd = 01 to 31)
year	(yy = 00 to 99).

For example, 07/04/95 represents July 4, 1995.

To set the clock:

Type **[T] [I] hh:mm:ss [ENTER]**

*Note: Use individual keys to spell time.
Do NOT use the functional [TIME] key.*

where hh:mm:ss represents the 24 hour clock in...

hours	(hh = 00 to 23)
minutes	(mm = 00 to 59)
seconds	(ss = 00 to 59).

The slash (/), colon (:), and comma (,) are all acceptable separators for both date and time.

Installing Expansion Cards

The HP 3396 Series III has two slots for expansion cards in the back panel. Expansion cards are explained in detail in the *Operating Manual*, chapter 5, *Data Storage*.

WARNING

Always turn the HP 3396 Series III OFF with the ON/OFF switch before inserting or removing expansion cards.

To install the expansion card:

1. Turn the HP 3396 Series III OFF.
2. Remove the expansion card from the package. Avoid touching the card surface.
3. Insert the card into one of the two card slots, located on the back panel of the HP 3396 Series III. The end with the small holes to fit onto the connectors goes in first. Push the card firmly into the slot. The black button next to the card slot should extend outward when the card is fully inserted.
4. Turn the HP 3396 Series III ON.
5. Type SYSTEM [ENTER] to see the system configuration and be sure the card was recognized.

To remove expansion cards from the card slots on the HP 3396 Series III:

1. Turn OFF the integrator;
2. Push the button next to the card you want to remove, until the card is fully disengaged from the slot;
3. Remove the card and turn on the integrator;
4. Type SYSTEM [ENTER] to see the new system configuration.

Connecting HP-IL Devices 3-2
Installing Signal Cables 3-9
Installing Sample/Remote Devices 3-12
Connecting RS-232-C Cables 3-17

Cable Connections

Cable Connections

Connecting HP-IL Devices

All of the interconnections between the HP 3396 Integrator and other devices are made at the integrator's rear panel.

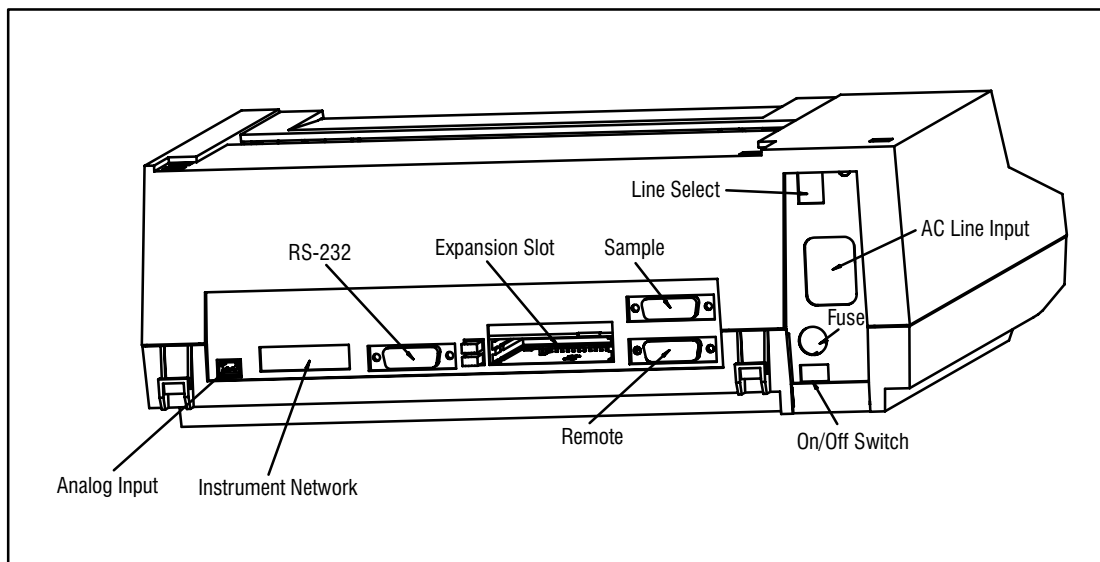

Figure 3-1. Integrator Rear Panel Cable Receptacles

Generally using roll paper provides enough room to connect cables without removing the roll of paper. However, if the z-fold paper and stand are used, the paper will conceal the rear panel's connections. The z-fold paper pack must be removed temporarily from the lower part of the stand and placed on top of the integrator until the cables are connected. Cables should be connected and then routed inside the stand's back edge to either side of the stand. When done, return the paper pack into the lower part of the stand.

It is best to have all of the instruments and devices turned-off before you connect any cables.

Although there are many cables that can be used to connect various devices with the HP 3396 Integrator, they generally fall into one of five types:

- **HP-IL Cables** Hewlett-Packard interface loop cables connect various HP-IL devices (e.g. flexible disk drives, printers, and specific analytical instruments) to an instrument network (INET) to communicate signal data, instrument setpoints, controls, and status signals, with the integrator. Moreover, certain HP-IB devices can be added to this loop when an HP-IL/HP-IB interface is used.
- **Signal Input Cables** Analog signal input cables connect the integrator to chromatographic signal voltages from various analytical instruments.
- **Sample Cables** The sample number (BCD) cable is used to connect a non-INET automatic sampler or sequencer to the integrator so that it can obtain sample number data.
- **Remote Cables** Remote control cables are used to communicate readiness to or from other (non-INET) instruments, start other devices, or start and stop the integrator under the control of other instruments.
- **RS-232-C Cables** Data communications RS-232-C cables can be used (when properly configured) to transmit and receive data and commands to a computer and/or other RS-232-C external devices.

Cable diagrams can be found in part 3 of this manual.

Cable Connections
Connecting RS-232-C Cables

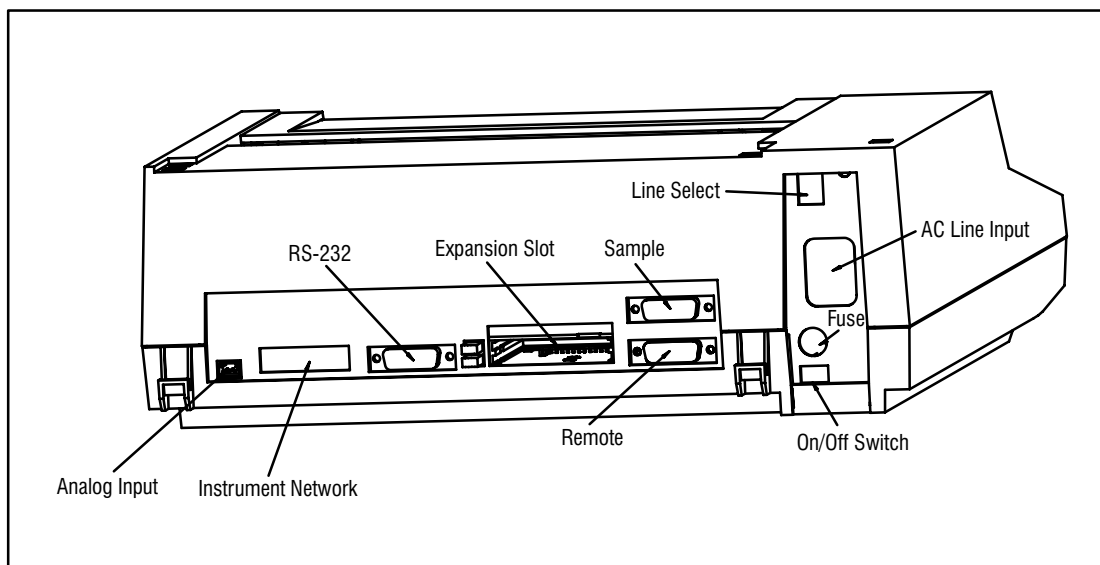

Figure 3-2. Integrator HP-IL Cable Receptacles

The Hewlett-Packard Interface Loop (HP-IL) is a two-wire loop for interfacing the HP 3396 Integrator to devices such as flexible-disk drives and printers. The interface loop is connected with HP-IL cables to the INSTRUMENT NETWORK receptacles on the rear panel of the HP 3396.

Besides the HP-IL devices mentioned above, the HP-IL can also accommodate the HP analytical Instrument Network (INET). This network allows the exchange of analytical data, instrument setpoints, and remote control and status signals among HP analytical instruments and the integrator.

HP 3396 Cables:	HP Part Number:
HP-IL Cable 0.5 m	82167-60001
HP-IL Cable 1.0 m	82167-60002
HP-IL Cable 5.0 m	82167-60003

Certain Hewlett-Packard Interface Bus (HP-IB) devices can be connected via HP-IL loop by using the HP 82169A HP-IL/HP-IB interface.

It is best to have all of the instruments and devices turned off before connecting any cables. This is particularly true when dealing with HP-IL cables.

Caution

In order for the integrator to properly configure the HP-IL system, all HP-IL cabling must be connected and all instruments/devices must be powered on before the integrator is energized.

Installing HP-IL and INET Devices

Conveniently arrange the INET and HP-IL devices so that the lengths of the HP-IL cables to be used will reach appropriate devices.

Starting with the HP 3396 Integrator, connect the output of one device to the input of another device with HP-IL cables, ultimately forming a single complete loop connecting all of the devices. Ensure that the connectors are inserted fully into the receptacles.

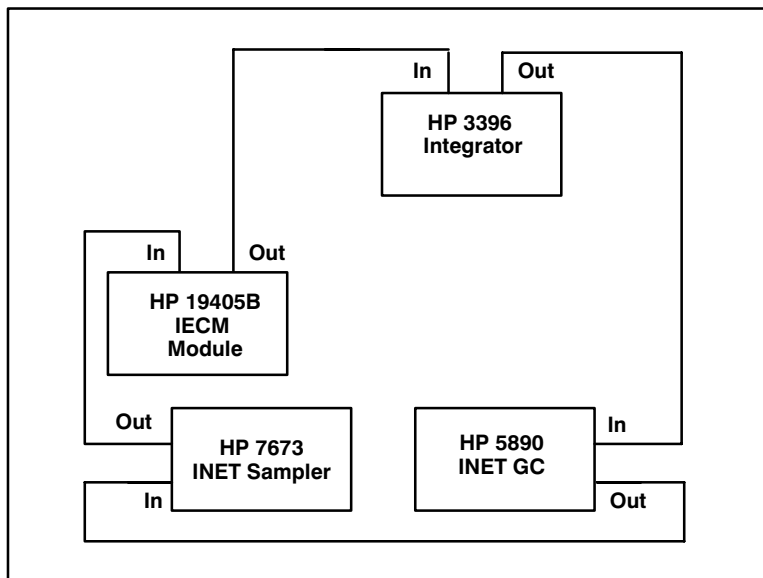

Figure 3-3. Example of Instrument Network Cabling

Installing the HP 19405B INTEG Event Control Module (IECM)

Install an IN end of an HP-IL cable into the rear panel of the HP 3396 integrator. Install an OUT connector of another HP-IL cable into the appropriate connector on the integrator. Install the other ends of the cables in the INSTR NETWORK receptacles (J1) on the rear of the IECM in a loop configuration. Refer to the HP 19405B installation instructions for more details.

Connect all other cabling (non-HP-IL) between the HP 19405B IECM and external devices.

Installing an HP-IB Disk Drive

This disk drive is no longer available; the HP 3396 is still compatible if you own one.

Connect an HP 82169A HP-IL/HP-IB Interface into the loop with the provided HP-IL cable.

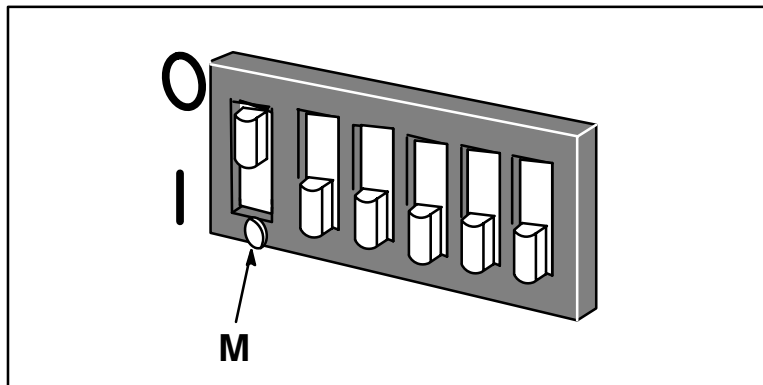

Figure 3-4. Switches on HP-IP/HP-IB Interface

Set the “MAILBOX/TRANSLATE” (M) switch (the switch with the dot under it) on the HP-IL/HP-IB Interface to the “TRANSLATE” position.

The “ADDRESS” switches on the Interface are not used; however, for the Interface to work properly, one of the switches (any one) must be set to 0, *not all be set to 1*. To be certain, all of the address switches could be set to 0.

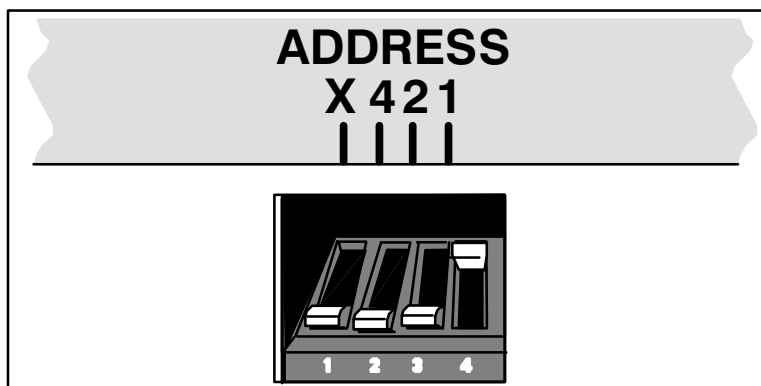

Figure 3-5. Switches on HP-IB Drive set to 1

Set the HP-IB disk drive address switches between 1 and 7. Refer to your disk drive manual for instructions of how to set the address.

Caution

Often the factory will set the address to zero. For the HP-IB device to configure properly, it must be set to any address between 1 and 7 (not zero).

During configuration, the HP 3396 integrator will assign each device's HP-IB address as its loop address.

Connect the HP-IB device to the HP-IL/HP-IB interface with an HP-IB cable.

Loop Power-Up

After all the devices are connected and appropriate hard addresses have been set on any HP-IB devices, you are ready to power-up the loop.

The loop must be continuous and complete. All HP-IL and INET instruments must be powered ON. If disk drives are included on the loop, wait for them to finish their start-up routines (often a minute or so).

Turn on the integrator and observe the self-test.

Installing Signal Cables

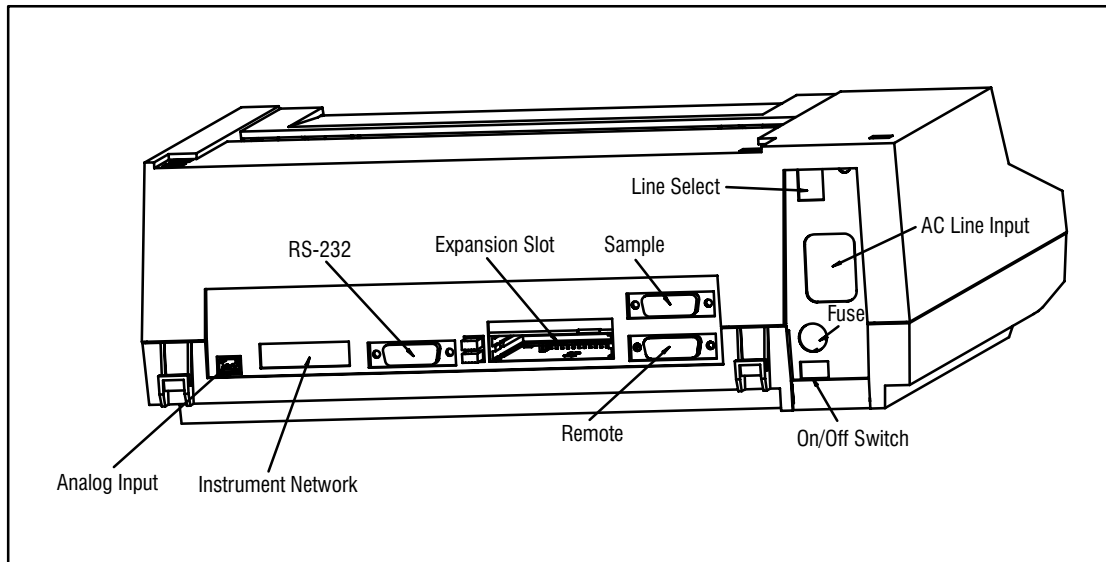

Figure 3-6. Integrator Signal Cable Receptacle

The analog signal input cable is used to connect chromatographic signal voltages from analytical instruments to the HP 3396 Integrator. Generally, the signal is supplied from the instrument's integrator output (rather than the attenuated recorder output).

Connections to Hewlett-Packard Analytical Instruments

Install the appropriate cable between the HP analytical instrument's INTEGRATOR output and the HP 3396 Integrator's INPUT receptacle.

Connects the HP 3396 Series II to:	HP Part Number
HP 5710/30 GCs and HP 1081B UV Detector	35900-60620
HP 5880A GC	35900-60570
HP 5790A GC	35900-60590
HP 1040 Diode Detector and HP 1090A/L LC	35900-60600
HP 5890A and HP 5890 Series II GCs	35900-60610
HP 1046A Fluorescence Detector	35900-60750
HP 6890 GC	G1530-60570

Connections to Non-Hewlett-Packard Analytical Instruments

The HP 3396 Integrator has floating (not earth-ground referenced) differential signal inputs. The maximum input signal should be limited to 1 volt.

Verify the signal voltage compatibility of the non-Hewlett-Packard instrument.

Caution

The input signal range is -10 mV to +1000 mV. The HP 3396 is protected against signals not exceeding ± 10 volts between the + and - signal leads. Between either signal input lead and earth ground, maximum permitted potential is ± 100 volts.

Use the general or special purpose signal cable to connect the integrator to your equipment.

Connects the HP 3396 to:	HP Part Number
Non-HP Equipment (general purpose, spade lug terminations)	35900-60630
Non-HP Equipment (special purpose, square pin terminations)	35900-60640

Installing Sample/Remote Devices

Note: An HP 7673 Automatic Sampler connected to the HP 3396 Integrator via Instrument Network (INET) does NOT use either a remote control or sample number cable. Remote control signals and sample number data are transmitted over INET cable. When the HP 5890 is the GC used, the HP 7673 is part of the INET loop. When the HP 6890 is the GC in use, the HP 7673 connects to the HP 6890 with an RSS cable, and is not part of the INET loop. See the HP 6890 *Reference* manual for cable information.

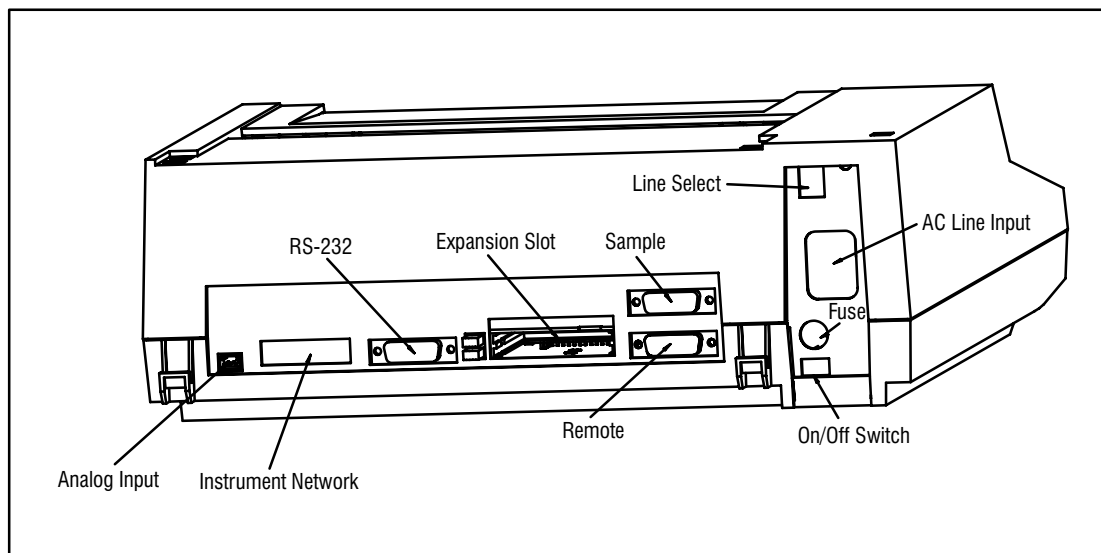

Figure 3-7. Integrator Control Cables Receptacles

Through the remote control cable, the HP 3396 Integrator can:

- be started and stopped under the control of other instruments.
- provide readiness status to other instruments.
- sense the readiness of other instruments.
- start other instruments.

Through the Sample Number (BCD) cable, the HP 3396 Integrator can:

- accept binary coded decimal sample number data from an automatic sampler or sequencer.

Installing the Sample Number (BCD) Cable

The sample number cable allows the HP 3396 to accept BCD (binary-coded decimal) sample number data from an automatic sampler or sequencer.

Plug one end of the BCD cable into the 15-pin SAMPLE receptacle on the rear panel of the HP 3396 Integrator.

If the instrument that supplies the BCD information is one of the Hewlett-Packard units indicated below, simply plug in the other end of the cable.

Connects the HP 3396 to:	HP Part Number
HP 7673 (Non-INET) Automatic Sampler	03396-60560
HP 1090 LC Auto Sampler	03396-60580
General Purpose (spade lug terminations)	03396-60530

If the general purpose cable is to be used, refer to the cable diagram in the Service section (Part 3) of this manual. Connect the appropriate wires at the end of the cable to the BCD signal source on the sampler or sequencer.

Connecting a Remote Control Cable to Hewlett-Packard Equipment

Install the indicated cable between the REMOTE receptacle on the back of the HP 3396 Series II Integrator and the Hewlett-Packard instrument.

Connects the HP 3396 to :	HP Part Number
HP 6890 GC	03396-61010
HP 5890A or HP 5890 Series II (analog output)	03394-60560
Second HP 3394 or 3396 Integrator	03394-60580
HP 1040 Diode Detector and HP 1090A/L LC	03396-60650
HP 1046A Fluorescence Detector	03394-60600

Connecting a Remote Control Cable to Non-Hewlett-Packard Units

Install the general purpose remote control cable for non-HP equipment between the REMOTE receptacle on the back of the integrator and the non-HP analytical instrument.

Connects the HP 3396 to :	HP Part Number
Non-HP equipment (spade lug terminations)	03396-61030

Determine which instrument will be the “controller”.

If the HP 3396 Integrator is to supply the “start,” one example of how the cable may be installed is shown below.

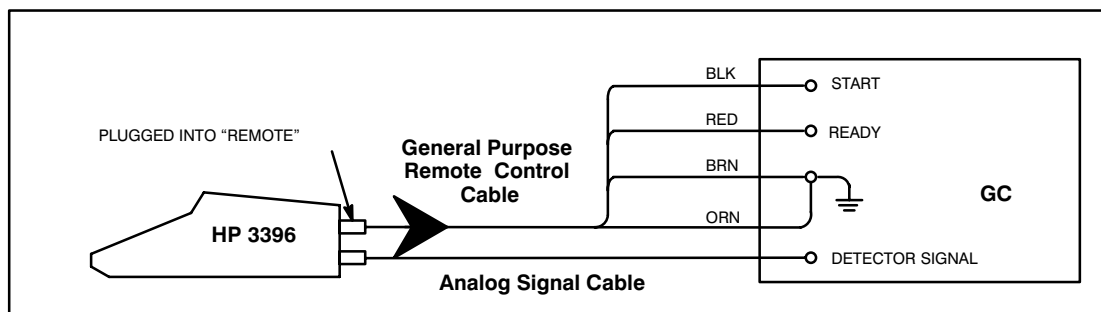

Figure 3-8. Remote Control Cabling

When [START] is pressed on the integrator, a one-second contact closure will be provided to the GC between the black (BLK) to orange (ORN) leads.

Note: Non-HP chromatographs used in temperature-programmed applications **MUST** be capable of having their oven temperature programmers started remotely by a one-second contact closure for properly automated operation under control of the HP 3396.

If you perform temperature-programmed analyses, the chromatograph also may be equipped with oven-ready sensing. If the oven-ready sensing function is not available, or is not used, the HP 3396 assumes the oven is *always ready*.

If the GC (or sampler) is to supply the “start” to the HP 3396 Integrator, one example of how the cable may be installed is shown below.

Cable Connections
Connecting RS-232-C Cables

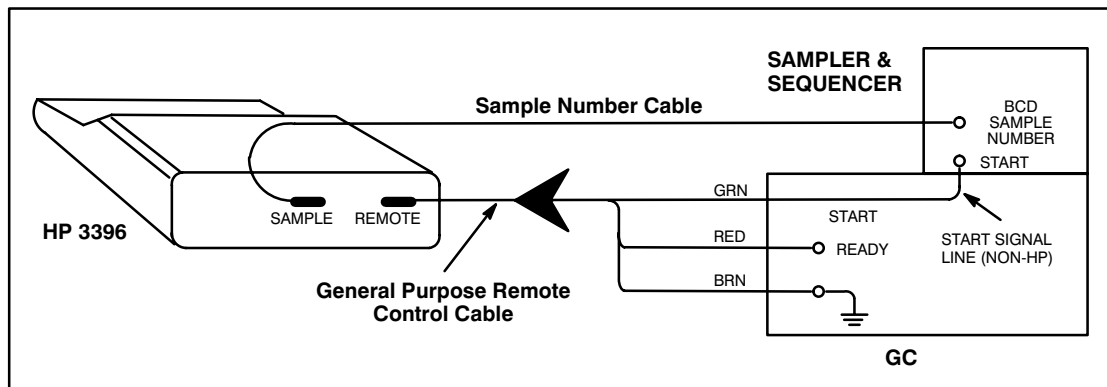

Figure 3-9. A Simple Automated System

Whenever the non-HP cable is to be used, refer to the cable diagram in the service section (Part 3) of this manual. Connect the appropriate wires at the end of the cable to the BCD signal source on the sampler or sequencer.

Connecting RS-232-C Cables

Note: The HP 3396 Integrator cannot function as a general purpose terminal.

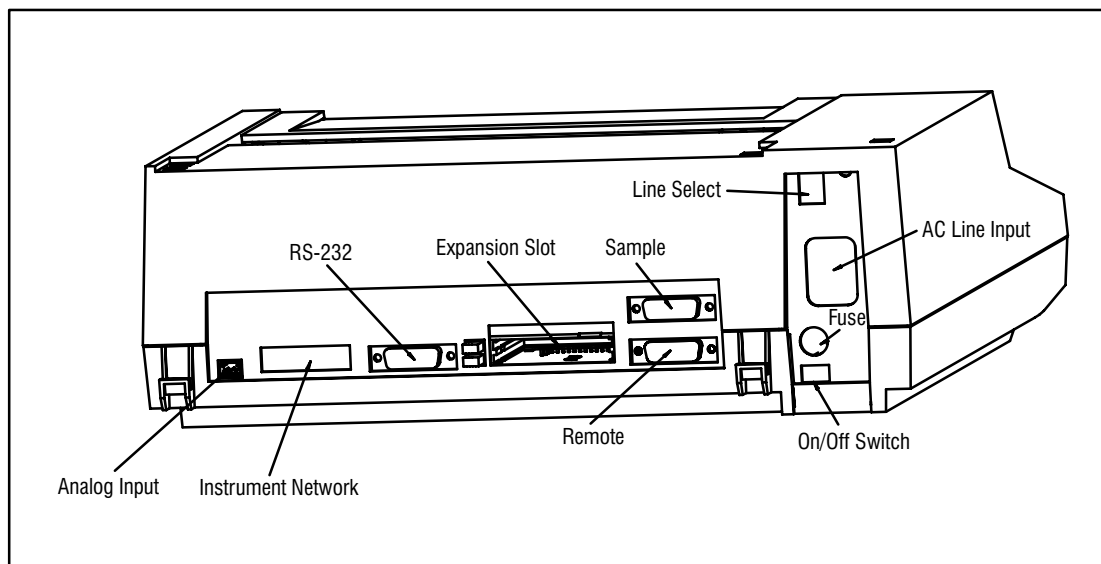

Figure 3-10. Integrator RS-232-C Cable Receptacle

The HP 3396 can be connected with a RS-232-C cable to a computer and other external devices to transmit and receive data and commands. The RS-232-C connection must conform to EIA (Electronic Industries Association) standards.

RS-232-C Interface installation is quite a bit more involved than simply choosing the proper cable and setting the configuration switches.

Communications between an HP 3396 and an external computing device require programs to be running on the host to operate the RS-232-C link.

Information about programs, required protocol, operation, cable selection, and configuration switch settings can be found in Book II of this manual.

Cable Connections
Connecting RS-232-C Cables

Exterior Cleaning 4-2
Removing/Reloading Paper 4-3
Maintaining the Printer 4-5

Routine Maintenance

Routine Maintenance

Exterior Cleaning

1. Periodically wipe clean the exterior of the case and printer window with a slightly damp cloth.

Avoid using chemical spray cleansers and organic-based detergent solutions and solvents when cleaning the integrator case.

2. At least once every six months inspect the ventilation grills along the right side of the HP 3396 Integrator and under the left-hand corner of the keyboard.

Clean the grills as necessary with a vacuum cleaner to remove dust and other obstructions.

Removing/Reloading Paper

Paper must be reloaded whenever the paper supply runs out or if the paper is intentionally removed for some other reason, e.g. if it is accidentally torn.

When the instrument runs out of paper, the HP 3396 will print

OUT OF PAPER: FEED W/ENTER, RESUME W/ESC .

Removing Paper from the Printer

1. Find a line of perforations between the roll and where it enters the printer mechanism. Tear along the perforations.
2. Open the printer window, lift the bail arms forward, and pull the remaining sheets of paper up and out of the mechanism.
3. If a low pressure air supply is readily available, it sometimes helps to blow air directly into the print mechanism to remove any small, loose particles of paper from the area. Removing the paper separator will provide improved access to the area. Replace the paper separator when completed.

Reloading Paper

The paper should be positioned on the rear of the top flat surface of the integrator with the PRINT THIS SIDE facing down against the surface. After rotating around the roller, the PRINT THIS SIDE will be correctly positioned facing up.

1. Remove the printer window by lifting it up and toward yourself.
2. Pull both bail arms forward to their open positions.

Routine Maintenance
Maintaining the Printer

3. Insert the paper into the slot under the paper separator. (It may be helpful to pull the paper separator forward temporarily until the paper is inserted.) Ensure that the edges of the roll of paper are flat and even.
4. Push the paper under the roller until its edge passes above the bail arms.
5. Align the holes in the left edge of the paper with the sprockets of the left pin wheel.
6. If necessary, adjust the right pin wheel to the width of the paper. It can move sideways to accommodate for minor differences in paper widths. Align the holes in the right side of the paper with the sprockets of the right pin wheel.

Be certain that the paper is straight and that both sides are even.

7. Push the bail arms back to their closed positions, locking the paper in position against the roller.

Verify that the paper's PRINT THIS SIDE is correctly positioned on the side of the paper toward the print cartridge. Replace the printer window.

8. Press **[SHIFT] [ENTER]** to feed the paper through the printer mechanism.

After paper has been reloaded, the green KEYBD indicator will continue to flash and the keyboard will be locked.

9. Press **[ESC]** to resume normal operation.

Maintaining the Printer

Caution

Never move the print carriage while the power is on. Doing so may cause damage to your printer. If you need to move the carriage, turn off the power and then slowly move it to the desired position.

Replacing the Blotter Pad

Replacing the blotter pad is the same procedure as its installation except that the old blotter must be removed first.

1. Remove the printer window.
2. Open the bail arms.
3. Turn the power off, then move the carriage away from the blotter.
4. Insert the tip of a pencil into the hole at the top of the blotter. Pull the pad up and away from its holder. Discard the used blotter.
5. Follow the installation instructions in chapter 2 for inserting the new pad.

Checking the Print Cartridge

Checking the print cartridge involves checking that the cartridge contains enough ink and that the ink flows easily. Chapter 2 of this manual provides instructions describing how to prime the cartridge and how to install a new cartridge should this prove necessary.

To check the ink level in a cartridge:

1. Remove the printer window.
2. Pull down the carriage cradle latch.
3. Remove the print cartridge.
4. Examine the print cartridge to determine the amount of ink in it.

If the bladder looks deflated like the one in the illustration below, it is low on ink and should be replaced.

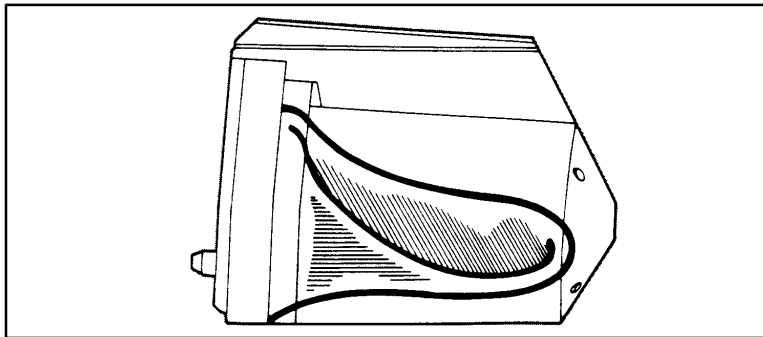

Figure 4-1. Empty Print Cartridge

5. If the bladder is low on ink, you should install a new print cartridge; see chapter 2.

If the bladder is not empty, the cartridge may need priming. When a print cartridge is new, clogged, or has been mechanically jarred, it often requires priming. Refer to chapter 2 for the priming procedure.

Cleaning the Carriage Contacts

If ink has seeped out of the cartridge onto the carriage, clean the carriage contact points with a swab dampened with water.

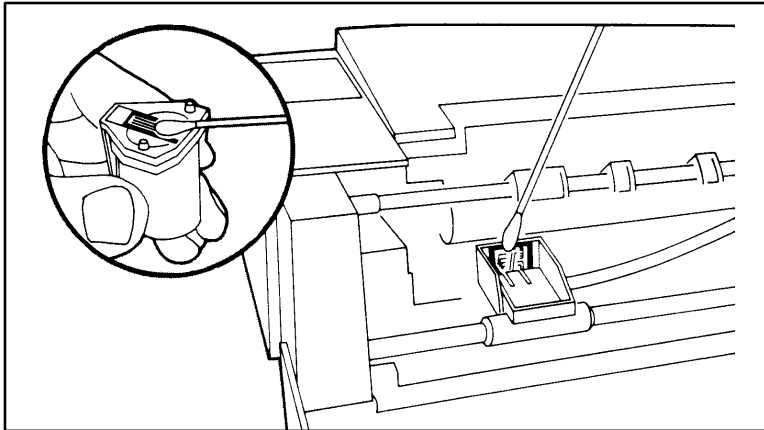

Figure 4-2. Cleaning the Nozzles and Carriage Contacts

Wipe the print cartridge face (nozzles) with a soft cloth or lint-free tissue.

Routine Maintenance
Maintaining the Printer

Filling out the Repair Information Form 5-2
Returning Your HP 3396 for Repair 5-5
Repacking Your Unit for Shipment 5-6
HP Service 5-7

Obtaining HP Service

Obtaining HP Service

Filling out the Repair Information Form

The Repair Information Form and shipping label are included in the Customer Information Envelope when the HP 3396 integrator is first shipped from the factory.

Please fill out this form completely and include it with your HP 3396 when the unit is returned to HP for repair.

If you can not locate the form, contact your nearest HP Sales and Service Office for more information.

A new blank form will accompany your HP 3396 when it is returned to you repaired.



HEWLETT
PACKARD

REPAIR INFORMATION FORM

For return-to-HP repair, please fill out this form and enclose it with your shipment.
This information will facilitate and expedite the repair.

WHO IS RETURNING THE EQUIPMENT?

Company/Institution _____ Date _____

Person to Contact _____ Phone _____

Alternate Contact _____ Phone _____

Return Shipping Address: _____

HOW WILL THE REPAIR BE PAID FOR?

Check one of the three boxes and fill in the information in that section:

Warranty: Received/Installed Date _____

Maintenance Contract: Contract No. _____

Order: Purchase Order No. _____

Except for contract and warranty repairs, a purchase order number and/or authorized signature must accompany your request for service. (If standard repair prices do not apply, a purchase order for the quoted price is required. Standard repair prices may be obtained by contacting the Field Repair Center.)

Authorized Signature _____ Phone _____

Billing Address: _____

WHAT IS BEING SENT?

Model No. _____ Serial No. _____

Be sure that you have followed the troubleshooting and test procedures described in the manual.
Enclose any printouts that help to show the failure.

Do not ship accessories which are not required to complete the repair (power cord, manuals, cables, etc.).

Creating the Little Falls Look
Using this document as an Interleaf template

WHAT SEEMS TO BE WRONG?

1. Describe how the failure appears. _____

2. Perform the confidence tests described in the manual. Which test, if any, produced a failure? _____

3. If failure is intermittent, how long does it take between failures? _____

4. List the system that this instrument is a part of. _____

5. Additional comments: _____

THANK YOU.

HP ANALYTICAL FIELD REPAIR CENTERS

IN THE USA:
NORTH AMERICAN FIELD REPAIR CENTER
Little Falls Site (4300)
2850 Centerville Road
Wilmington, DE 19808

IN WEST GERMANY:
HEWLETT-PACKARD GmbH
Reparaturzentrum Analytische Messtechnik
Ermlis-Allee
D-7517 Waldbronn 2
Phone: 7243-6021

ELSEWHERE:
Contact your local HP Analytical Sales and
Service Office for information.

35900-90200

Returning Your HP 3396 for Repair

The standard HP warranty features return-to-bench repair, including postage and handling.

- In the United States:
 1. Fill out both sides of the Repair Information Form completely.
 2. Attach a copy of the form to the HP 3396.
 3. Pack the unit securely (see “Repacking Your Unit for Shipment” on the next page).
 4. Use the peel-off address label (also included in the customer information envelope) and affix it to the outside of the shipping carton.
- Elsewhere:
 1. Fill out both sides of the Repair Information Form completely.
 2. Contact your nearest HP Sales and Service Office for instructions on getting your unit returned for repair. A complete list of offices is included in the back of this manual.
 3. Attach a copy of the form to the HP 3396.
 4. Pack the unit securely (see “Repacking your Unit for Shipment”).
 - a. Send the unit to an HP-designated service facility.

Repacking Your Unit for Shipment

1. To prepare the HP 3396 for shipment, remove paper from the printer mechanism and unsnap paper roll holders from the rear of the instrument. Remove the print cartridge from the print carriage.
2. To repack your HP 3396 for shipment, we recommend that you use the original shipping container. If the original packing materials are not available, be sure to use a carton of at least 250-pounds test. Pack the HP 3396 Integrator with at least two inches of padding on all sides.
3. Do not include any operating accessories (including cables) with the HP 3396 unless the problem relates to an accessory.
4. On the Repair Information Form, be sure you detail the following items when you return your HP 3396 for repair:
 - A description of the exact configuration at the time of the malfunction, including the interface cable, computer, peripherals, and software in use.
 - A brief description of symptoms for service personnel, including any printout that shows what happened.
 - The serial number of the HP 3396 (located on the lower left portion of the rear panel).
 - Include your name, address, and a phone number at which you may be reached during the day.
5. Attach the Return Shipping Label originally packed in the Customer Information Envelope to the outside of the shipping carton.
6. Since in-transit damage is not covered by the warranty, we suggest that you always insure shipments.

HP Service

On-site service of your HP 3396 is available on a time-and-material basis or under a maintenance agreement.

To request on-site service:

1. Fill out the reverse side of the Repair Information Form.
2. Call your local HP Sales and Service Office. Have the following information available (look on the back panel of your integrator for this information):
 - Model number: HP 3396C, M, etc.
 - Instrument Name: HP 3396 Series III.
 - Serial number: From the rear of the instrument.
 - Information from the reverse side of the Repair Information Form.

Creating the Little Falls Look
Using this document as an Interleaf template

6

Power Problems	6-2
Signal Problems	6-5
System Problems	6-9
Running the Automatic Power-On Tests	6-14

Troubleshooting

Troubleshooting

Power Problems

No Response at Initial Turn On (Unit does not function)

Probable Causes

- Voltage selection switch set improperly. (Instrument set to 115 V and plugged in to a 230 V circuit.)
- Power is not available to HP 3396 Integrator.
- Fuse is blown.

Suggested Actions

1. Check that the line voltage selection switch on the rear panel is set to the proper voltage value (either 115 V or 230 V).
2. Check that the power cord is connected between the integrator and a live ac power source.

If the wall receptacle is “dead”, contact your local electrician.

3. Check that the rear panel power switch is ON.
4. Check that the integrator’s fuse is of the proper 3-ampere value and is not blown.

Checking the Fuse

The fuse is located near the power switch on the rear panel of the HP 3396 Integrator.

1. Turn the power switch on the rear panel OFF.
2. Disconnect the line power cord from both the wall receptacle and the rear of the integrator.

WARNING

FAILURE TO REMOVE THE POWER CORD FROM THE INTEGRATOR COULD RESULT IN ELECTRIC SHOCK AND PERSONAL INJURY.

3. Locate the fuse cap below the AC LINE socket.
4. Insert a small flathead screwdriver into the fusecap. Pushing in slightly, turn the fuse cap counterclockwise to free it.
5. Remove the fuse and visually inspect it. The wire inside the fuse should be unbroken. If the wire is broken, the fuse is defective.
6. If the fuse looks okay, reinstall it and look elsewhere for the problem. If the fuse is defective, replace it with a new fuse (3A, 250VAC, IEC 127 Type F, quick-acting, 3AG).

Caution

If fuse blows a second time, contact HP service.

“Power failed” Messages Appear After Working

Probable Causes

- Incorrect ac line voltage selection. (Integrator is set to 230 V and connected to a 115 V circuit.)
- Poor line power supplied.

Suggested Actions

1. If the line voltage selection switch on the rear panel is set improperly, change it.
2. Have an electrician check the line power for noise and/or surges.

COMM Indicator Light Blinks After Initial Turn On Tests Are Complete

Probable Causes

- DATACOMM switches set incorrectly.
- Faulty cable connection.

Suggested Actions

1. Are the DATACOMM switches set correctly? If a host computer is not connected to the integrator, set the timeout duration switch to “short”. This is about 15 seconds. *
2. Is the cable connector in the REMOTE port seated properly?

***Note:** If switches are changed, the integrator must either be power cycled or [CTRL] [BREAK] for the new settings to be read.

Signal Problems

Data Represents a Zero or Straight Baseline with INET Instruments

Probable Causes

- Disconnected or faulty HP-IL cables.
- C1 data path is inactive.
- Problem with chromatograph.

Suggested Actions

1. Check that all INET cables are connected.
2. Check status of C1 Data path using INET_CONFIGURATION command or INET LIST command. C1 Pros and C1 Cons should say "IDLE".
3. Check that the HP 5890 GC or HP 1090L LC has compatible firmware. (All HP 6890 firmware is compatible.)
 - A revision letter of "C" or higher must appear on the HP 5890 GC at turn on.
 - The HP 1090L LC code must be B2616 or higher.
4. Check chromatograph; refer to the chromatograph's operating manual for details.
5. If the suggestions in steps 1-4 did not help, obtain HP service.

**Data Represents a Zero or Straight Baseline,
or is Pinned at Maximum Value with Analog Signal**

Probable Causes

- Signal switch on rear panel is in wrong position.
- Problem with chromatograph.
- Cabling problems.

Suggested Actions

1. Is the signal switch in the OPERATE (middle) position?
2. Is the instrument supplying the signal operating properly?
3. Is the signal within the range of -10 mV to +1 V?
4. If a general-purpose signal cable is being used, are the connections to the signal source correct?
5. Disconnect the HP 3396 from other equipment, then turn to “Running the Self-Test Diagnostics” in section 7 of this manual.
6. Run test L, the Print/Plot test.
 - If the test passes, run A/D test.
 - If the test fails, obtain HP service.
7. Run test B, the A/D Test.
 - If test passes, run 0V and 1V tests.
 - If test fails, obtain HP service.
8. Turn to “Running the Signal Tests” and run the 0V and 1V Tests.
 - If tests pass, there is a chromatographic or cabling problem.
 - If tests fail, obtain HP service.
9. Is INET cable connected?
If INET is connected, C1 Pros and C1 Cons should say “IDLE”. Check configuration.

Excessive Noise or Drift on Chromatogram

Probable Causes

- Signal source malfunction or improper control settings.
- Signal itself drifts or is noisy (problem with chromatograph).
- Cabling problem.

Suggested Actions

1. Is the instrument supplying the signal operating properly? Are the signal output controls set appropriately?
2. Is the signal from the analytical instrument drifting or noisy?
3. If a general-purpose signal cable is being used, are the connections to the signal source secure?
4. Disconnect the HP 3396 from other equipment.
5. Turn to “Running the Self-Test Diagnostics” in section 7 of this manual. Run Test B, the A/D test.
 - If the test passes, the cable or a connection is defective.
 - If the test fails, go to next step.
6. Turn to “Running the Signal Tests”. Run the 0V and 1V Tests.
 - If all tests pass, there is a chromatographic or cabling problem.
 - If tests fail, obtain HP service.

Reported, Processed, or Raw Data Are Not What You Expected

Probable Causes

- Signal source malfunction or improper controls settings.
- Signal itself is at fault.
- Cabling problem.
- Inactive INET data path.
- Calculation or calibration problem.

Suggested Actions

1. Is the instrument supplying the signal operating properly?
2. Is the signal being applied within the range of -10 mV to +1 V (analog only)?
3. If a general-purpose signal cable is being used, are the connections to the signal source correct?
4. If INET is being used, verify that the C1 data path is active.
5. Was the proper calculation chosen? Check if PKWD and THRSH were properly set.
6. Turn to “Running Self-Test Diagnostics” in this chapter and run Test T, Demo Chromatogram. If demo chromatogram is okay, continue with step 7.
7. Disconnect the HP 3396 from other equipment, then run Test B, the A/D test.
 - If test passes, run 0V and 1V tests.
 - If test fails, obtain HP service.
8. Turn to “Running the Signal Tests” and run the 0V and 1V tests.
 - If the tests pass, the cable is defective or signal is at fault.

System Problems

Integrator Cannot Be Started or Stopped from an External Device

Probable Causes

- Problem with external device.
- Capability not provided by cable or external device.
- Disconnected or faulty cable.
- Signal incompatibility.

Suggested Actions

1. Is the external device working?
2. Do the instrument and cable both have the capability of starting or stopping the HP 3396? Requires a one-second contact closure.
3. Is the remote control cable securely and properly connected?
4. Turn to “Running Self-Test Diagnostics”. Run Test 9, the remote control and sample input test. If test fails, obtain HP service.
5. For custom cable connections, verify compatibility of signals between the remote instrument and the HP 3396.
6. If the suggestions in steps 1-5 did not help, obtain HP service.

HP 3396 Does Not Start or Stop an External Device

Probable Causes

- Problem with external device.
- Capability not provided by cable or recognized by remote unit.
- Disconnected or faulty cable.
- Signal incompatibility.

Suggested Actions

1. Have any error messages been printed?
2. Is the external device working?
3. Do the external device and the cable both have the capability of being activated by the HP 3396?

Integrator provides a one-second contact closure between SO1 and SO2 output pins on the remote cable.

4. Is the remote control cable securely and properly connected?
5. For custom cable connections, verify compatibility of signals between the HP 3396 Series II and the external device.
6. If the suggestions in steps 1-5 did not help, obtain HP service.

HP 3396 Does Not Communicate with RS-232-C Device

Probable causes

- Host computer not properly programmed.
- HP 3396 HP 5890 GC with an HP 19395A (Y-cable) 03394-60610 configuration switches set incorrectly.
- Improper or faulty cables.

Suggested Actions

1. Check compatibility and programming of host computer.
2. Check configuration switch settings using the system command. Are they correct? You can override the default settings with the SSET RS232 command; see RS232 connections section of this manual.
3. Are all cables in question securely connected and operative?

“LOOP DOWN” Message Printed

Probable Causes

- HP-IL or INET instrument is not functioning.
- Disconnected or faulty HP-IL cable.
- Environmental problem (site requirements not met).

Suggested Actions

1. Has HP-IL been installed properly?
2. Go Turn to “Running the Self-Test Diagnostics”. With the all INET instruments connected in the loop and powered on, perform test 8 (HP-IL bus test).
 - If the test passes, HP-IL is working.
 - If the test fails, subtract one instrument at a time from the loop until the test passes in order to identify the defective instrument or cable.
3. Verify an individual HP-IL or INET device by running its self-test.
4. If all instruments are working, check HP-IL cables. Connect all cables together in a loop and then connect them to the HP 3396 Series II. Turn to “Running Self-Test Diagnostics” and run test 7, the HP-IL port test.
 - If the test passes, all cables are okay.
 - If the HP-IL port test fails, remove one cable at a time until the test passes in order to identify the defective cable.
5. Check power mains for line faults.
6. If the suggestions in steps 1-5 did not help, obtain HP service.

External Sample Number is Missing or Inaccurate

Probable Causes

- Cabling problem.

Suggested Actions

1. Is the sample number cable connected properly?
2. Is the BCD sense wire in the correct position for the application?
3. Verify the integrity of sample number cable.
4. Turn to “Running Self-Test Diagnostics” and run Test 9, remote control and sample number input test.
 - If test passes, cable is at fault.
 - If test fails, call HP service.

Running the Automatic Power-On Tests

The automatic power-on tests help you isolate problems quickly when the HP 3396 is suspected of being at fault.

1. Invoke a cold-start by simultaneously pressing the [CTRL] and [DEL] keys. The operating parameters are restored to their default values and the information stored on the memory disk M: are lost during a cold-start. The integrator also performs a series of self-tests during a cold-start.
2. Keyboard indicators monitor the progress of the tests and freeze in a particular pattern if a failure occurs.
3. If the instrument prints firmware revision numbers (Z80/HOST/INET/PP) and the printer/plotter confidence test properly appears, the green KEYBOARD indicator is ON and an asterisk prompt prints out, the unit has passed the tests.

```
*! "#$%&'(> **+, - ./0123456789:;<=>?@ABCDEFGHIJKLMN OPQRSTUUVWXYZ[\]^_`abcde  
fghijklmnopqrstu vwxyz{|}~`!:";<=>?@ABCDEFGHIJKLMN OPQRSTUUVWXYZ[\]^_`abcde  
" Performing self test; unit will  
accept commands when KEYBD led is ON  
  
Model 3396C PLUS BASIC, Rev C.00.12 10/28/94  
Z80/HOST/INET/PP Rev = j/a/d/b w/ GC_a04
```

Figure 6-1. Printer/Plotter Confidence Test.

Troubleshooting
Running the Automatic Power-On Tests

Purpose of This Section 7-2
Safety Information 7-2
Running the Self-Test Diagnostics 7-3
Description of Self-Test Diagnostics 7-6
Running the Signal Tests 7-15
Zero-Volt Input Test 7-17
One-Volt Input Test 7-18
Diagnostic Procedures 7-19
Disassembly and Reassembly Instructions 7-34

Diagnostics

Diagnosics

Purpose of This Section

The purpose of this section is to provide additional information about servicing your HP 3396. This information is important for qualified service technicians or for reference by Hewlett-Packard customer engineers servicing your instrument at your location. The information presented here does not mean that these servicing procedures can be performed by you. Only qualified service engineers should attempt any of the test or disassembly procedures described here.

Safety Information

Caution

Circuit cards contain static-sensitive devices. Do not remove the instrument cover or keyboard except at an approved electrostatic-free workstation.

WARNING

THE POWER SUPPLY MODULE IS A DIRECT LINE-POWERED SWITCH-MODE SUPPLY. ELECTRICAL NODES ON THIS MODULE CAN BE AT POTENTIALS UP TO 370 V DC. USE EXTREME CARE WHEN MEASURING LOW-VOLTAGE DC OUTPUTS.

Running the Self-Test Diagnostics

If the HP 3396 fails to operate as expected, an instrument connected to the HP 3396 may be at fault. The HP 3396 Integrator has built-in self-test procedures that are useful in determining which instrument, if any, in the “system” is at fault. Document any information that you receive from these tests to report to your Hewlett-Packard service representative.

Caution

Save all BASIC programs, methods, and other files, if possible, on an external disk drive or expansion card before starting the self-test diagnostics.

1. To start the self-test diagnostics, simultaneously press the following keys:

[CTRL] [SHIFT] [BREAK]

Hold them down until the instrument starts printing. If you release any of these keys too soon, the diagnostics will not start.

2. If you pressed the above three keys correctly, you’ll see this printout:

```
SELF TEST (Press (M) key for more help)
=>
```

3. Type **[M]** to list the tests available. Figure 7-1 is a printout of this list.

Diagnostics Diagnostic Procedures

```
=> M

Press the keys for the tests you want to perform. If you select
no tests, you will return to the system software. After you have
selected the tests you want, press ENTER. The tests will run
continuously unless an error halts them.

(0) Clear all tests and demo chromatogram
(1) ROM crc and bank select test
(2) Quick RAM test
(3) Extended RAM test (20 min per 128K)
(4) 8051 ROM and RAM test
(5) 8051 interface test
(6) RS232 port test
(7) HP-IL port & bus test
(8) PCMCIA socket test (requires loop-back connector)
(9) Remote control and sample # input test
(B) A/D noise test
(L) P/P test
(K) Keyboard test
(N) High speed printer test
(O) P/P ROM and RAM test
(A) Run all tests
(T) Enable demo chromatogram

(P) Print error messages
(S) Suppress error messages
(C) Continue testing if error occurs
(H) Halt testing if error occurs
    (press SPACE to continue)

=>
```

Figure 7-1. Self-Test Diagnostic Menu

4. Type the number or letter for the desired tests after the prompt, =>. If you strike an incorrect test number, press **[0]** (zero) immediately afterward to clear all previous test selections.
5. Press **[P]** to print all self-test error messages, or press **[S]** to suppress all error messages.

6. Press **[H]** after the appropriate test numbers to halt testing when an error occurs. Press the space bar after an error prints out to resume testing.

Press **[C]** after the appropriate test numbers to resume testing after an error occurs.

Note: If **[S]** is not pressed, **[P]** is assumed, and if **[H]** is not pressed, **[C]** is assumed.

7. Press **[ENTER]** to start the test(s).

The set of self-test diagnostics run continuously unless you press **[H]** to halt testing after the first error. The keyboard indicators (LEDs) display which diagnostic tests are being run. Information codes for an error are printed if you do not press **[S]**.

See the section titled “Interpreting Diagnostic Test Failures” in this chapter for additional information on how to interpret diagnostic messages.

Tests from this dialog can confirm a fault discovered during the power-on self-tests or determine if the HP 3396 Series II is the instrument in a “system” that is at fault.

8. To halt all testing, turn the integrator off.

When you want to halt the demo chromatogram without turning the instrument off, press **[CTRL] [SHIFT] [BREAK]** to reinitiate the diagnostic menu, then press **[0]** to exit this menu and return to the system prompt. This method preserves internal memory.

Description of Self-Test Diagnostics

- (1) **ROM CRC and Bank Select Test**—The data contents of ROM are manipulated mathematically by a special algorithm (a cyclic redundancy check-16 routine). The resultant value after all ROM locations are operated on will be zero. If the value is not zero, the ROM is declared defective and an error message will be printed. A bank select test is also performed that checks switching between the operating system ROM and the diagnostic ROM.
- (2) **Quick RAM Test**—This test performs a walking-1s and a walking-0s test throughout RAM. An arbitrary pattern is then written into RAM by the CPU and is read back for accuracy. Any incorrect data will cause the test to fail.
- (3) **Extended RAM Test**—Permutated data is written into every location of RAM and then read back for verification.
- (4) **8051 ROM and RAM Tests**—The HOST CPU performs a CRC-16 routine to test its internal ROM. If the resultant checksum is incorrect, this test fails and a corresponding error message will be printed. The HP-IL/INET CPU also does a CRC-16 routine on the applications EPROM if installed. The Z80A main CPU then requests each I/O CPU (HOST and INET) to test its internal RAM. Each I/O CPU will write permutated data into the internal RAM and reads the data back for verification.
- (5) **8051 Interface Tests**—Data is written into RAM by the Z80A CPU then permutated by the HOST CPU. The Z80A then checks the modification and permutates the data again. The HP-IL/INET CPU modifies the data pattern that is again checked by the Z80A. After this test has been performed for every third location in RAM, the Z80A will reread these locations to verify the correct data.
- (6) **RS-232-C Port Test**—This test requires the connection of the DataComm loopback test connector (HP part number 03396-60540) to

the connector on the back panel. This connector loops back the TXD (transmit) output to the RXD (receive) input. Data is then written to the port, looped back to the input by the connector, and then read by the CPU for accuracy.

- (7) **HP-IL/INET Bus Test**—This test requires the connection of an HP-IL cable to the rear panel INET IN and OUT jacks. The interpreter will transmit all possible INET data patterns onto the loop and read them back to verify correct reception of the data. During this test, the HP 3396 may remain connected to other instruments on INET. This test is particularly useful for identifying which instrument on the loop is causing the fault. If the test fails, one instrument at a time can be removed until the test passes, verifying the faulty instrument.
- (8) **PCMCIA Socket Test**—This test requires the connection of two PCMCIA loopback test connectors to the PCMCIA sockets on the back panel. It is used by the factory to verify the manufacturing process. To test the sockets at a customer site, exercise PCMCIA functionality with an expansion card known to be in good working order.
- (9) **Remote Control and Sample Number Input Test**—This test verifies the remote and sample connectors by connecting a jumper wire between the pins of the connectors. The HP 3396 will print out a response which can be compared to the INFO values in tables 7-9 and 7-10 for accuracy.
- (B) **A/D Noise Test**—This test checks the HP 3396 analog-to-digital subsystem for internal noise. All operating parameters are set internally for plotting the noise signal. Be sure the HP 3396 has been powered ON for at least 30 minutes before running this test.

An example of an A/D test is shown in figure 7-2. If the number for peak-to-peak noise on your printout is 3.0 or less, the test passes.

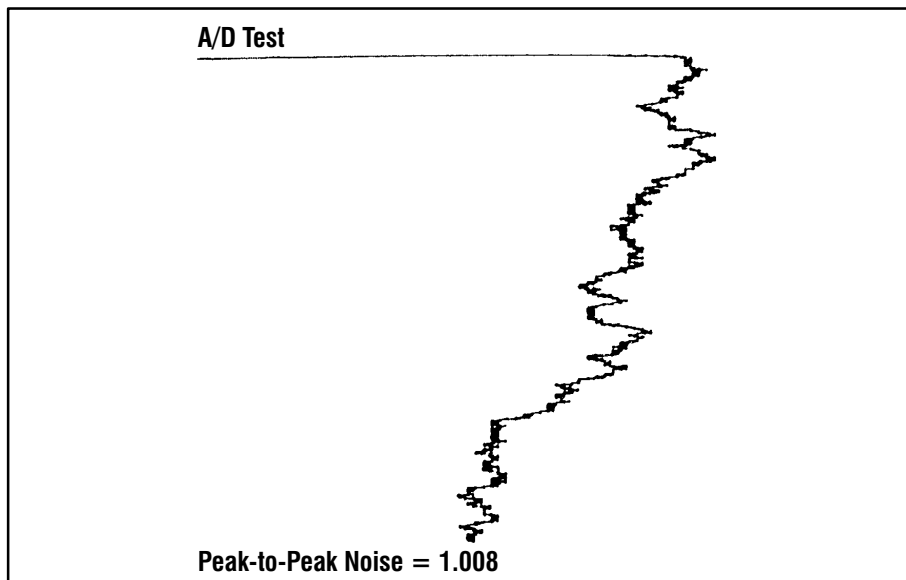

Figure 7-2. A/D Test Results

(L) P/P Test (Print/Plot Test)—This test will print out four lines of the entire HP 3396 character set. The first two lines will be in large font, and the second two lines will be in small font; then, a diagonal line and a horizontal line will be plotted across the full width of the paper. The printout can be checked visually for any irregularities. (See example in figure 7-3.)

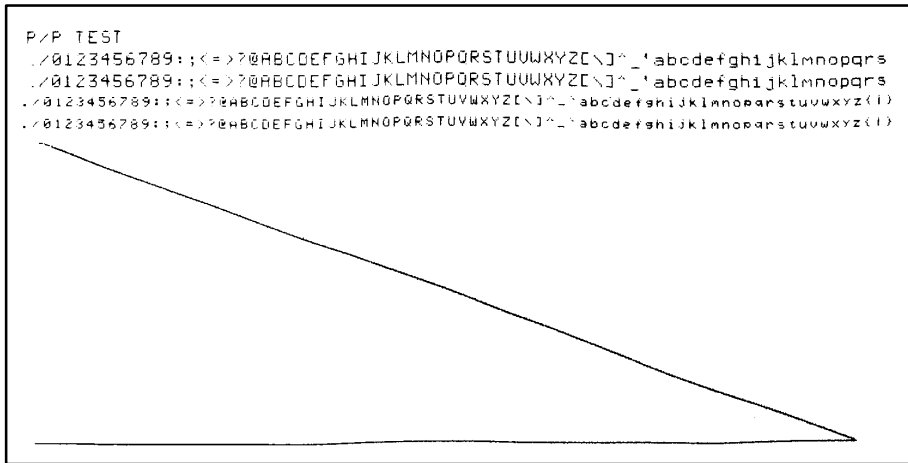

Figure 7-3. Example of Test L

- (K) Keyboard Test**—The keyboard test will verify that the keyboard is functional by printing the key presses.
- (N) High-Speed Printer**—One possible problem in the printer/plotter subsystem is slippage of the printhead motor. This would appear as a baseline offset in a real chromatogram. The test provides an excellent means for evaluating potential motor slippage because of the rigorous test plot with annotation. The test generates 10 seconds of square wave plot followed by 110 seconds of random noise, with annotation. The noise is followed by another 10 seconds of square wave. If slippage were to occur, it would probably occur during the noise plot because of the high torque requirements on the motor. Any motor slippage would be detected by observing the square waves. The distance from the left and right edges of the paper to the edges of the plot would vary depending on whether the motor slipped. (See figure 7-4.)

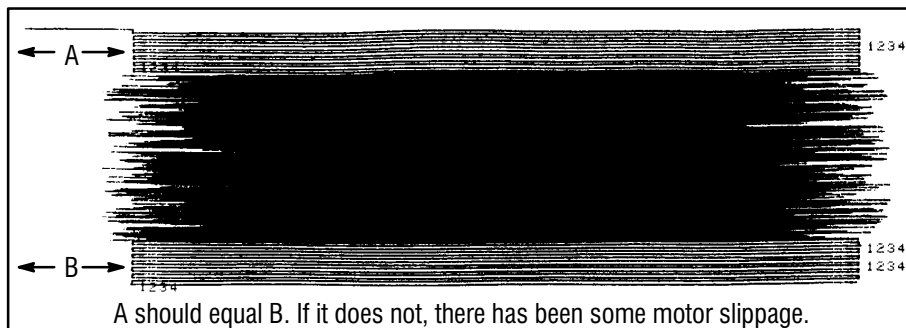

Figure 7-4. Example of Test N

After running at least one pass of the test, observe the distance from the edge of the plot to the edge of the first set of square waves. Compare this distance to the distance in the second set of square waves. If they are the same, the motor did not slip. In most cases, slippage indicates a defective motor.

- (O) P/P ROM and RAM Test**—This test checks the internal ROM of the print/plot processor using a CRC test similar to test 1. Both the print/plot internal RAM and external RAM are tested similar to test 2, the quick RAM test. Data is written into the RAM and then read back from the RAM for verification. Any errors would result in a test failure and an appropriate error message will be printed. Failure of this test at power-on will result in numbers (1 to 7) being printed instead of the internal character set (see figure 7-5).

Diagnostics
Diagnostic Procedures

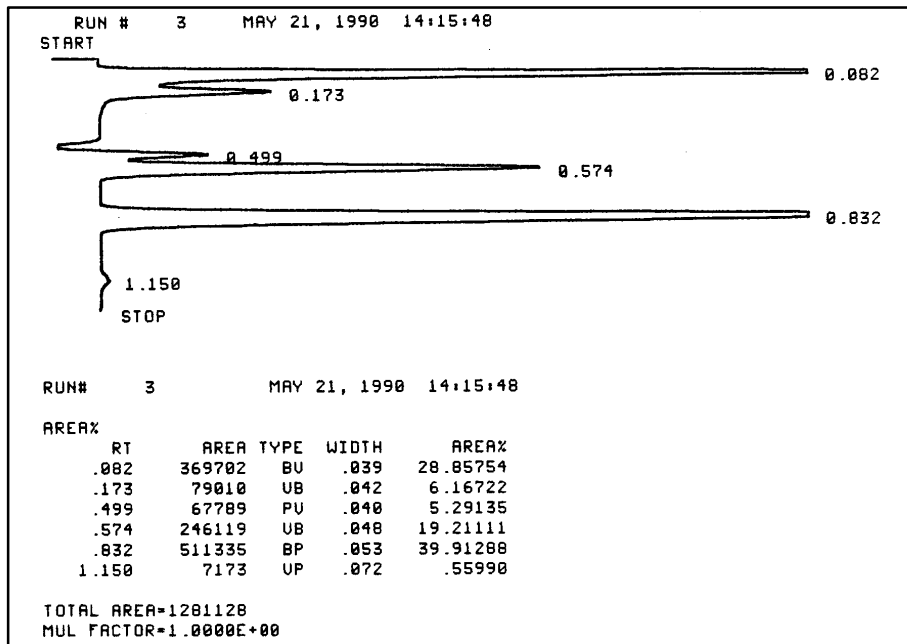

Figure 7-6. Example of Demo Chromatogram Test T

Performing Test T

1. Disconnect any HP-IL cables from rear of instrument.
2. After selecting test T, set [ATT 2 ^] to 4 and [CHT SP] to 4.
3. Press the [START] key to begin the chromatogram.
4. Press the [STOP] key to end the chromatogram after the peak marked with a retention time of 1.150 has been plotted. The demo chromatogram should resemble figure 7-6.

Keyboard status indicator sequence—Whenever a self-test is selected, it will run continuously until the unit is turned off. The keyboard status indicators (LEDs) will indicate which test is running, according to table 7-1. At the conclusion of the test, all indicators will blink, indicating a successful completion of the test. If a test fails, an appropriate error message will be printed. (See “Interpreting Diagnostic Test Failures” in this chapter.) At power-on the integrator runs tests 1, 2, 4, 5, and 0 as part of the power-on self-test.

Table 1–1. Keyboard Status Indicators Sequence

Test No.	KYBD	COMM	READY	RUN
1	Off	Off	Off	On
2	Off	Off	On	Off
3	Off	Off	On	On
4	Off	On	Off	Off
5	Off	On	Off	On
6	Off	On	On	Off
7	Off	On	On	On
8	On	Off	Off	Off
9	On	Off	Off	On
B	On	Off	On	Off
L	On	Off	On	On
K	On	On	Off	Off
N	On	On	On	On
0	On	On	Off	On

Table 1–2. Equipment Needed for Self-Test Diagnostics

Test Number	Equipment Needed	Installation Jack
6	Test connector HP part number 03396-60540	COMPUTER
7	HP-IL cable(s)	INSTRUMENT NETWORK
8	HP-IL cable(s) and device(s)	INSTRUMENT NETWORK
A	Test connector HP-IL cable(s)	COMPUTER INSTRUMENT NETWORK
T	None	

Before selecting tests 6, 7, 8, 9, B, and T, follow the appropriate instructions below.

- Test 6** Connect the test connector (HP part number 03396-60540) to the rear panel “RS232” jack.
- Test 7** Connect one or more HP-IL cables to the “INSTRUMENT NETWORK” jacks on the rear of the HP 3396.
- Test 8** Leave any HP-IL or INET devices connected to the HP 3396 via HP-IL cables.
- Test 9** Disconnect any remote control or sample number cables connected to the integrator before running the test.
- Test B** Before selecting this test:
1. Set the analog input switch to the 0-V (down) position with a small, straight-blade screwdriver.
 2. Make sure the unit has been powered-on for at least 30 minutes.

Running the Signal Tests

In addition to the self-test diagnostics, A/D signal problems can be detected using the 0-V and 1-V tests described in this section.

Caution

Save all BASIC programs, methods, and other files, if possible, on an external disc drive or expansion card before starting the 0-V and 1-V input tests.

The SSET ANALOG Command

The SSET ANALOG command is used to change the A/D reference voltage for the following tests:

ONE-VOLT INPUT TEST;

ONE-VOLT PLOT TEST;

ZERO-VOLT INPUT TEST;

ZERO-VOLT PLOT TEST.

The current analog input setting is shown with every SYSTEM command. The last line printed by the HP 3396 after a SYSTEM command is:

ANALOG INPUT IS NORMAL AND IS ACTIVE

If the reference voltage has been changed, the response to the SYSTEM command will reflect the change.

The reference voltage can be changed either from the system prompt (*) or from the BASIC prompt (<). It can be set for 0 or 1 volts. To set the reference voltage to 1V, type:

SSET ANALOG R1 [ENTER]

The HP 3396's response to a SYSTEM command now ends:

ANALOG INPUT IS 1V REF AND IS ACTIVE

Diagnostics
Diagnostic Procedures

To change to a 0 volt reference, type:

```
SSET ANALOG R0
```

The last line of the SYSTEM command response is now:

```
ANALOG INPUT IS 0V REF AND IS ACTIVE
```

After conducting the test you must return the system to NORMAL operating mode using the SSET ANALOG command again. Type:

```
SSET ANALOG RN
```

If the SSET ANALOG command is used improperly, the HP 3396 prints the following error message:

```
SSET ANALOG WANTS VALUE "R0", "R1", OR "RN"
```

If you start a run with the analog input set to 0 or 1 with the SSET ANALOG command, the run header is appended to as a warning that the reference input was plotted. The following message appears.

```
* RUN # 1   JAN 1, 1901   00:01:02           ANALOG INPUT R0
```

You should set the analog input to NORMAL, and then repeat the run.

Zero-Volt Input Test

The zero-volt input test reports the value of a 0-V input signal as measured by the HP 3396. The reported value can be inspected to ensure that it is within acceptable limits.

1. Use the **SSET ANALOG** command to set the analog voltage to zero. Allow the input to stabilize for several minutes.

Then press

[LIST] [ZERO]

The HP 3396 prints

LIST: ZERO = *xx, yyyy.yyy*

where *xx* is the plot position of the printhead as a percentage of full-scale deflection, and *yyyy.yyy* is the value (in millivolts) of the 0-V input signal as measured by the HP 3396.

The *yyyy.yyy* value must be 0 ± 4 mV.

One-Volt Input Test

The one-volt input test reports the value of a 1-V input test signal measured by the HP 3396.

1. Use the **SSET ANALOG** command to set the analog voltage to one. Allow the input to stabilize for several minutes.

Then press

[LIST] [ZERO]

The HP 3396 prints

```
LIST: ZERO = xx, yyyy.yyy
```

where *xx* is the plot position of the printhead as a percentage of full-scale deflection, and *yyyy.yyy* is the value (in millivolts) of the zero input signal as measured by the HP 3396.

The *yyyy.yyy* value should be between 800 and 1084.

2. Repeat **[LIST] [ZERO]** several times. The voltage measured should be consistently between 800 and 1084.

Diagnostic Procedures

Measuring dc Supply Voltages

The power supply module, HP part number 0950-1884, provides three regulated voltages to the main PC board. These voltages are used either directly by circuits on the board or are converted to other voltages for special purposes. The 5-V supply is used for CPUs, memory, general logic circuits, and paper motor drive. The +12-V supply is used for the print carriage motor drive, ink dot firing, and A/D converter. The -12-V supply is used for RS-232-C communication and printer analog circuits.

The dc supply voltages can be measured under three conditions: isolated, idle load, and full load. When checking these voltages, be sure that you match the test limits on the supply with the conditions of the test. Refer to table 7-4 for the test limits for each voltage under each of these conditions. The supply test points can be located at the left rear corner of the main PC board. See tables 7-3 and 7-5 and figure 7-9 for detail identifying the test points.

Equipment required:

- Voltmeter, at least 3-1/2 digits resolution
- 15-ohm 2-watt resistor (HP part number 0698-3605)

Follow the instructions in this chapter and disassemble the unit through “Remove the Print Mechanism.”

WARNING

IT IS DANGEROUS AND UNNECESSARY TO PROBE THE POWER SUPPLY VOLTAGES AT THE POWER SUPPLY END OF THE DC CABLE. HIGH VOLTAGES EXIST ON THE HEAT SINKS AND OTHER COMPONENTS OF THE POWER SUPPLY MODULE.

Idle Load Measurement

To measure the voltages at idle load conditions, do the following:

1. Disconnect motor cables from P8 and P3.
2. Apply power to the unit.
3. Measure dc voltages at the P2 test points.
4. Turn off power.

Full-load Voltage Drop Measurement

The full-load test is performed differently when looking at the 5-V supply or the +12-V supply. To test the 5-V supply at full load, do the following:

1. Connect the paper motor at P8.
2. Disconnect the print carrier motor P3.
3. Disconnect paper sensor cable at P7.
4. Connect voltmeter leads to test pins at P2.
5. Apply power to the unit.

The initial reading should be near the idle measurement, but as the confidence test proceeds (after about 9 seconds), the voltage should drop. The lowest reading obtained before the keyboard LEDs go out should be used to verify the full-load drop.

6. Turn off power.

To test the +12-V supply at full load, do the following:

1. Disconnect the paper sensor cable from P7.
2. Disconnect the paper motor from P8.
3. Connect the print carriage motor to P3.

4. Remove the print cartridge.
5. Apply power and observe the power supply voltages during the high-speed motions of the print carriage during the confidence test interval. Use the lowest reading to calculate observed full-load voltage drop.
6. Turn off power.

Isolated Measurement

This measurement must be made with an approximately 15-ohm load on the +5-V supply.

If a load resistor is not available, either print mechanism motor can be used as a load for the +5-V supply. Use two 24-AWG solid or tinned stranded jumper wires to connect pins 3 and 9 of the dc cable to pins 1 (red) and 2 (brown) of either motor. This will provide a 14-ohm load for this test.

1. Find the dc supply cable that passes through the main sheet metal bracket and remove it from main board connector P1. (See figure 7-11 for detail on removing this connector).
2. Obtain a 15-ohm 2-watt resistor (HP part number 0698-3605) with at least 3/4-in.-long leads. Bend the leads at right angles to the body to form a U shape.
3. Insert the resistor leads directly into the dc cable between pins 3 and 9.
4. Apply power to the unit. The voltages should then be checked by probing the exposed contacts on the top of the connector body.
5. Turn off power.

Table 1–3. Test and Interconnect Points

Item	Shown in Figure	Description	Test Point
1	7-9	DC Secondary Connection	P1
2	7-9	DC Test Points	P2
3	7-9	Optical Sensor Connection	P4
4	7-9	Paper Drive Connection	P8
5	7-9	Print Carriage Connection	P3
6	7-9	Out-of-Paper Sense Connection	P7
21	8-1	AC Primary Connection	J1
8	7-9	Print Cartridge Connection	J3

Table 1–4. The dc Voltage Measurement Limits

Supply	Isolated	Idle Load	Voltage Drop Full Load
+5 V	5.16 to 5.26	5.10 to 5.19	40 to 100 mV
+12 V	10.75 to 13.75	11.30 to 13.62	50 to 200 mV
–12 V	–10.5 to –14.5	–10.98 to –14.1	Not Applicable

Table 1–5. The dc Voltage Test Points

Supply	Isolated	Idle, Full Load
Common	DC Cable pin 3 or 8	P2 pin 5
+5 V	DC Cable pin 4 or 9	P2 pin 7
+12 V	DC Cable pin 7 or 2	P2 pin 3
–12 V	DC Cable pin 6 or 1	P2 pin 1

Measuring Motor Windings

This procedure is used to test for internal shorts in either the print carrier or the paper drive motor. The same procedure is used for both motors.

The equipment required is an ohmmeter with sensitive low ohms range (200 ohms or less).

Turn off power.

Follow the disassembly instructions up to and including “Remove the Top Cover.”

Do the following for each motor:

1. Disconnect the motor from the main PC board from P8 or P3.
2. Probe the exposed crimp contacts on the top of the connector.
3. Compare the readings obtained to the limits in tables 7-6 and 7-7 for that motor.

Table 1–6. Print Carriage Motor Winding Resistances

Red to Brown	12.6 to 15.4 ohms
Blue to Yellow	12.6 to 15.4 ohms
Note: The motor has two white wires. The following measurements will show an OPEN CIRCUIT to one white wire and show indicated value to the other white wire.	
Red or Brown to White	6.3 to 7.7 ohms
Blue or Yellow to White or Black	6.3 to 7.7 ohms

Table 1–7. Paper Drive Motor Winding Resistances

Red to Brown	13 to 15.8 ohms
Blue to Yellow	13 to 15.8 ohms
Note: The motor has two white wires. The following measurements will show an OPEN CIRCUIT to one white wire and show indicated value to the other white wire.	
Red or Brown to White	6.5 to 7.9 ohms
Blue or Yellow to White	6.5 to 7.9 ohms

Partitioning Failures

All diagnostic tests are for circuitry on the main PC board as described in chapter 5. A failure of any of these tests (resulting in an 'ERROR=' message) strongly indicates an electronic failure on this circuit card. If the Power-On Confidence Tests do not run at all, then the problem can be on the main PC board or the power supply module. Paper or pen motion failures in the confidence test or any diagnostic might indicate a printer problem but more likely a main PC board problem.

Before performing any of the troubleshooting procedures detailed below, do the following:

1. Remove any cables from the rear panel.
2. Disassemble the unit through "Remove the Top Cover."
3. Remove the print cartridge.

Module Level Troubleshooting

The following troubleshooting tree is based on symptoms that are observed during the power-on confidence tests. Each observable symptom is followed by several potential causes. For each cause there is an action listed that will confirm the cause and indicate the recommended repair. If the cause is not confirmed, continue with the next potential cause. When you reach the last cause for the symptom, no confirmation is required. Please refer to chapter 5 for a description of the proper behavior of the power-on confidence tests. If the instrument fails to execute these tests, find the appropriate symptom from the following charts. Follow the recommended actions in the order indicated.

SYMPTOM: LEDs do not light at power-on.

Cause	Action
Improper ac Connection	<ol style="list-style-type: none">1. Check fuse and line power connections. Correct if necessary.2. Check for ac line voltage at ac module J1, pins 5 and 7. If line voltage is absent, double-check the fuse and line connections; replace ac module if connections are good.
Z-80 CPU Kernel Problem	<ol style="list-style-type: none">3. Check dc voltages at main PC board test points, P2. If voltages are good, replace main PC board.
DC Voltage Problem	<ol style="list-style-type: none">4. Carefully check main PC board and both printer motors for overheating. The power supply is capable of providing enough excess power to make an overloaded circuit heat obviously. If there are no signs of an overload, the power supply is probably defective. Replace the power supply.
Overload on Main PC Board	<ol style="list-style-type: none">5. If both print mechanism motors do not overheat (they dissipate about 7 watts during print and plot modes) and there is an overheated circuit on the main PC board, replace the main PC board.
Overload on Print Mechanism	<ol style="list-style-type: none">6. Disconnect the overheated motor. Refer to table 7-6 or 7-7 and measure the winding resistances. If the motor is beyond this range, replace the motor or the print mechanism. If both windings of the motor are within the specified resistance range, proceed.
Internal Main PC Board Failure	<ol style="list-style-type: none">7. Replace the main PC board.

**SYMPTOM: LEDs remain on continuously after power-on.
Print carriage motion may be erratic.**

Cause	Action
Power Supply Problem	<ol style="list-style-type: none">1. See table 7-5 and measure the +5- and +12-V supplies under isolated conditions. Replace the power supply module if out of range, as per test limits in table 7-4.2. Measure +5- and +12-V supply at idle and full load. If voltage drop is greater than the specified amount in the table, replace the power supply.
Defective Paper Drive Motor	<ol style="list-style-type: none">3. Disconnect paper drive motor from P8 and reapply power. If LEDs go out after several seconds and indicate confidence test activity, the paper drive motor is shorted internally. Replace the motor or the print mechanism.
Z-80 Kernel Problem	<ol style="list-style-type: none">4. Replace the main PC board.

SYMPTOM: Print carriage does not move or it chatters and moves erratically. Paper feed may or may not be normal. LEDs indicate proper confidence test activity.

Cause	Action
Power Supply Problem	<ol style="list-style-type: none">1. See table 7-5 and measure the +12 and –12-V supplies under isolated and idle conditions. Check the test limits from table 7-4 and replace supply module if out of range.2. Measure +12-V supply at full load. If voltage drop is greater than the specified amount, replace the power supply.
Print Carriage Motor Is Defective	<ol style="list-style-type: none">3. Turn off power. Remove paper drive motor from P8. Remove print carriage motor from P3. <i>Slowly</i> move print carriage to center of mechanism. Reconnect print carriage motor to P8. Leave paper sensor connected to P7. Apply power to unit. After several seconds, the print carriage should make three or four motions to the left for a total of about 1.35 inches. If it does not move, moves erratically, or makes excessive noise, the motor is probably defective. Replace the motor or print mechanism. Alternatively refer to table 7-6 and measure the print carriage motor winding resistance. Replace the motor or the print mechanism if out of range.
Drive Electronics Are Defective	<ol style="list-style-type: none">4. Replace the main PC board.

**SYMPTOM: Paper does not feed or feeds slowly or erratically.
Print carriage motion appears normal.**

Cause	Action
Blocked Paper Path	<ol style="list-style-type: none">1. Check paper path for obstructions.2. Check that the paper separator is installed properly.3. If Z-fold paper was in use, switch to roll paper unless a Hewlett-Packard paper stand was used.
Paper Drive Motor Defective	<ol style="list-style-type: none">4. Disconnect power from unit. Remove print mechanism. Set the print mechanism down on the board and rotate it so that the paper drive motor is to the rear and its shield is resting on the instrument's rear panel. Connect paper motor to P3. Connect out-of-paper sense cable to P7. Connect the optical sensor cable to P4. Apply power to unit. The paper feed grit wheels should immediately rotate "backward" for a fraction of a second and then reverse and feed smoothly for about two seconds. It will then hesitate slightly as the motor slips. Switch the power off and on again and observe the <i>initial</i> motion again. The initial two seconds of motion in both directions should be quiet and smooth. If the paper feed wheels do not move, move erratically, or make excessive noise, the motor is probably defective. Replace the motor or print mechanism. Alternatively refer to table 7-7 and measure the paper motor winding resistance. Replace motor or print mechanism if out of range.
Paper Drive Electronics Defective	<ol style="list-style-type: none">5. Replace main PC board.

Interpreting Diagnostic Test Failures

This section will help you to understand the results of some of the self-test diagnostics.

Several diagnostic tests can identify specific defective socketed components for replacement. Table 7-8 lists these tests, the ERROR and INFO data that are printed for a failure of the test, and the action to correct the problem.

For any other diagnostic test failure, replace the main PC board.

Table 1–8. Diagnostic Error Messages for Socketed Components

Test	ERROR = INFO =	Action
(1)	ERROR = 01H INFO = xxyyH	If xx = FF or 00 through 08, replace U68.
	ERROR = 03H	ROM version error. Check U62 for compatibility.
(4)	ERROR = 22H or 23H	Replace U27.
	ERROR = 42H or 43H	Replace U17.
	ERROR = 44H	Replace U68. (Application EPROM)
(0)	ERROR = 0DH INFO = 003xH	If x = 1, 2, or 3, replace the print/plot processor U50.

Two of the diagnostic tests can be performed with accessory hardware to verify the unit with a greater confidence level. These tests are the remote and sample number test and the RS-232-C port test. Both tests should be performed with the instrument fully assembled.

Remote and Sample Number Test

Equipment Required

- Three-inch length of 20-AWG solid or tinned stranded jumper wire

Test Procedure

1. Remove any connecting cables from the remote and sample receptacles on the rear panel.
2. Enter the self-test dialog and select test 9 and press **[ENTER]** to begin repetitive testing.
3. Connect the jumper wire to pin 9 on the sample number connector. Connect the other end of the wire as per table 7-9, and observe the printed error message. The **ERROR** part of the message should be ignored. Compare the **INFO =** value to those in the table. Only connect the jumper long enough to cause the error message to print.
4. Similarly, connect the jumper wire from pin 9 on the remote connector to other pins on the remote connector and check for **INFO =** values from table 7-10.

If no error message is printed for any pin combination listed, it may indicate a failure in U22 or U23. Replace the main PC board.

Table 1–9. Sample Connector Test

Sample No. Pin	INFO =
1	8002H
2	8008H
3	8004H
4	8001H
5	8100H
6	8800H
7	8400H
8	8200H
10	8040H

Table 1–10. Remote Connector Test

Remote Pin No.	INFO =
3	1080H
5	8010H
6	C000H
7	8020H
8	A000H

RS-232-C Cable Testing

The RS-232-C loopback test can be used to test the integrator alone or with a communications cable attached. By testing the instrument in both configurations, you can identify which element of the system is faulty and avoid unnecessary service charges.

Testing the instrument alone is described in chapter 2 of this manual under the heading “Running the Self-Test Diagnostics.” Connect jumper wires between the pins in table 7–11 depending on which connector you are using. If you are testing without a connector, jumper the 15-pin female on the instrument as per table 7–11.

Be sure to test it while the instrument is in good working order!

To test the instrument and its RS-232-C cable, first you have to locate a compatible loopback connector for the opposite end of the cable. This may be a 25-pin or a 9-pin connector, with male or female contacts. Obtain a proper mating connector and wire it for loopback as shown in table 7-11. Test the loopback connector on a known good cable before relying on it when a failure occurs.

Loopback connectors for standard connector sizes are available from computer supply and accessory distributors. If the advertised wiring includes the connections shown in table 7-11, then it should be suitable for the diagnostic test. Additional connections, such as pins 6 to 20 in the 25-pin connector, will not affect the test.

Run Diagnostic Test 6 with the RS-232-C cable connected to the integrator and the 25- or 9-pin loopback connector on the other end. If this test fails after passing with the 15-pin alone, the cable is defective.

Note: The hardware handshake signals CA and CB are not wired in the DCE cables (HP part numbers 03396-50520 and 03396-60530); thus, the test cannot pass without an error message. When testing either one of these cables with a loopback connector, an ERROR = 24H indicates that the cable passes the continuity test of the transmitted data and received data lines. If ERROR = 25H is printed, it indicates a failure of these lines.

Table 1–11. Loopback Connector Wiring

Connector Size	Connect Pins
9-pin Male	2 to 3
15-pin Male	1 to 13 and 2 to 14
25-pin M/F	2 to 3 and 4 to 5

Disassembly and Reassembly Instructions

Equipment Required

- Small size 1 pt Pozidriv screwdriver
- Large size 2 pt Pozidriv screwdriver
- Pry tool (HP part number 8710-1347)
- Small 1/8-in. flat-blade screwdriver
- Replacement self-tapping screws (HP part number 0624-0427)

WARNING

DISCONNECT AC POWER SOURCE BEFORE OPENING THE CASE.

Remove Power from the Unit

1. Turn the unit off by depressing the line switch located in the left rear of the instrument.
2. Remove the power cord.

Remove the Paper

1. Tear the paper at a serration before the point where it enters the print mechanism, open the printer window, lift the bail arms forward, and pull the remaining paper up and out of the mechanism.
2. Remove the roll from the paper hangers (if installed).

Remove the Paper Hangers (if Installed)

1. Apply slight pressure to the locking tabs on the bottom of the hangers and pull up.

Remove the Printer Window

1. Lift the window up.
2. With the thumb and forefinger, apply slight pressure to the left-hand side of the window to release the window from the locking tab and lift the window up. Notice that the tab on the left-hand side is slotted.

Remove the Paper Separator

1. Pull forward and lift up.

Remove the Keyboard

1. Insert the pry tool between the top of the keyboard and the case on the right-hand side, and apply slight downward pressure until the locking tab releases. Repeat the process in the middle and on the left side, and lift the keyboard up.
2. While holding the keyboard with one hand, grasp the ribbon cable with the other hand and carefully pull the cable out of the keyboard.

Remove the Top Cover

1. With the large Pozidriv, remove the two self-tapping screws in the front of the unit under the keyboard. The middle hole is not used.
2. With the large Pozidriv, remove the two self-tapping screws located under the printer window.
3. With the large Pozidriv, remove the two self-tapping screws in the square openings in the rear of the unit.
4. Lift the top cover off.

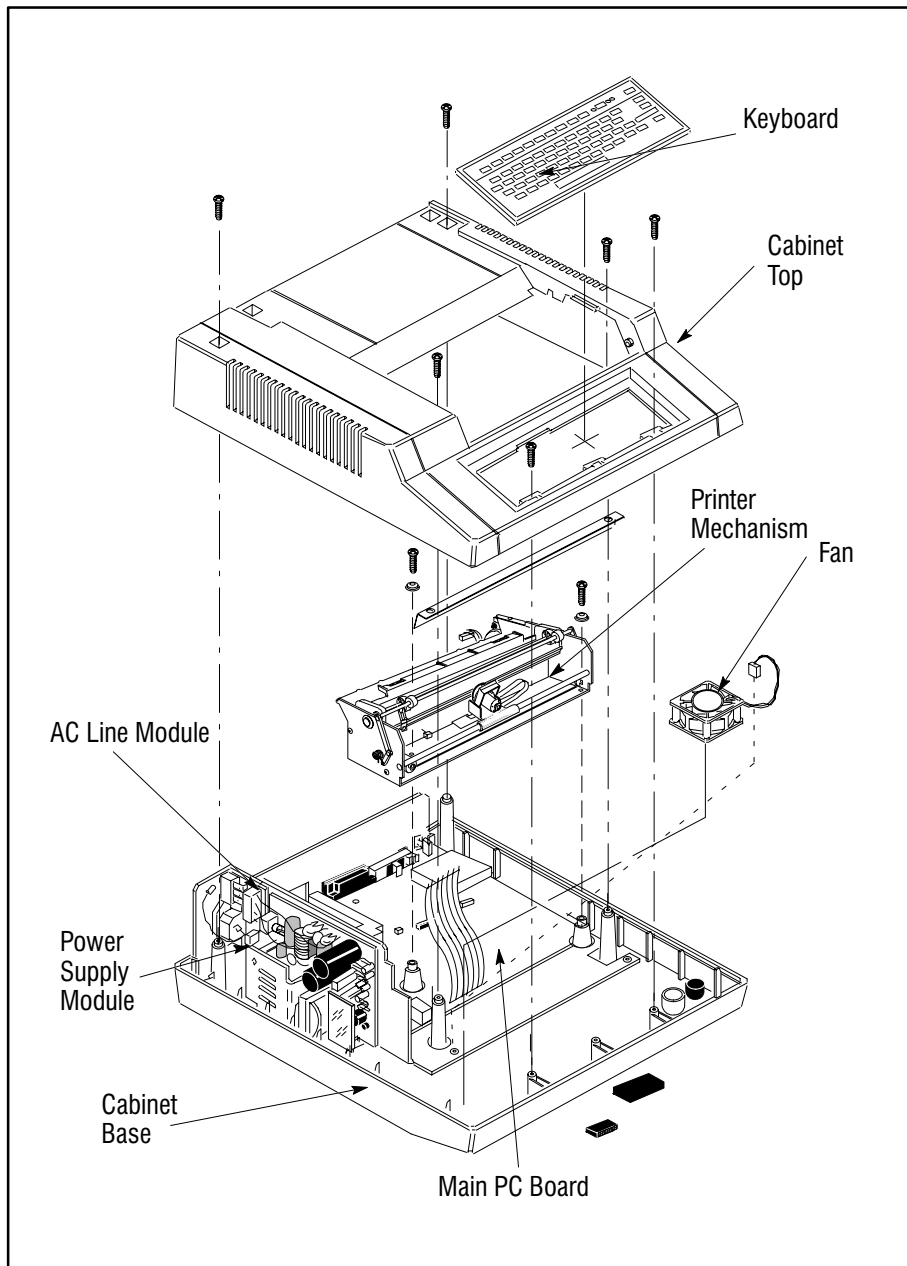

Figure 7-8. Instrument View with Printer Removed

Remove the Print Mechanism

1. Remove the aluminum shield from the two posts in front of the print mechanism.
2. With the large Pozidriv, remove the two self-tapping screws in the front of the mechanism that secure the mechanism to the case. Be careful not to lose the cupped washers.
3. Turn the unit around so that you are facing the rear panel.
4. See figure 7-9 and tables 7-3 and 8-1 to identify and remove the following printer cables. Remove the print carriage motor cable from connector P3. Remove the optical sensor cable from connector P4. Remove the flexible print cartridge cable from J3, noting that it only makes contact on one side. Remove the out-of-paper sensor cable from connector P7. Remove the paper drive motor cable from connector P8.

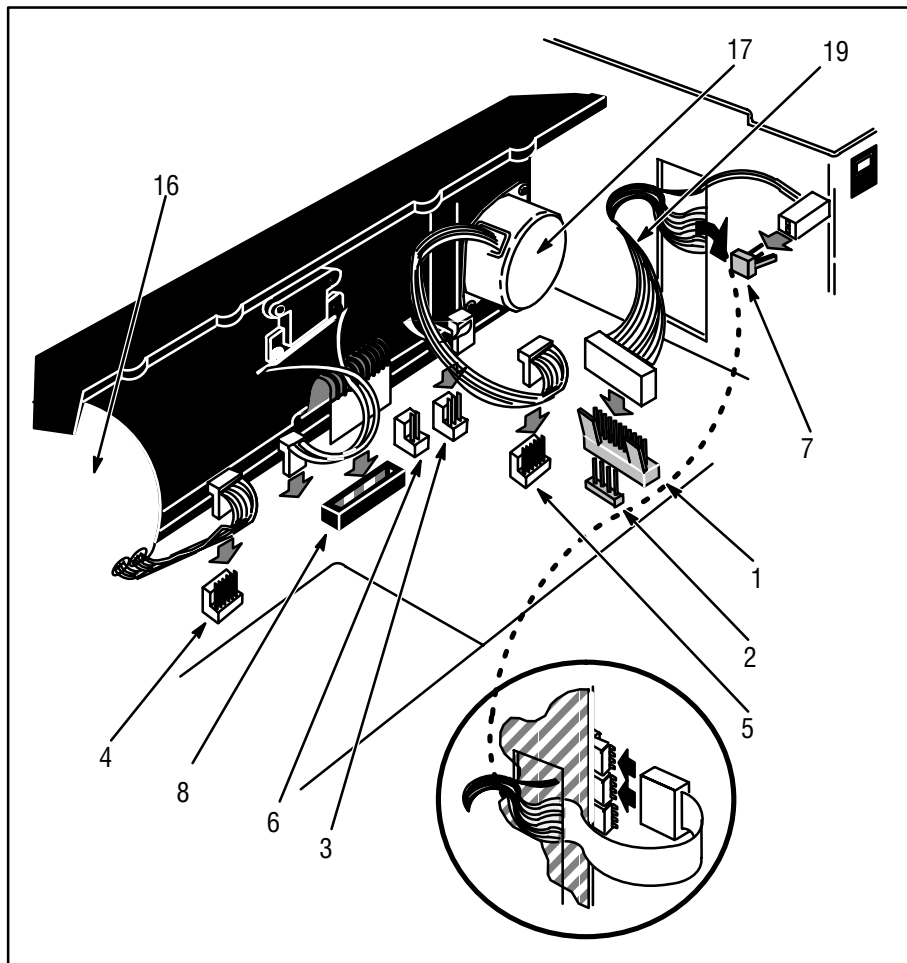

Figure 7-9. Print Mechanism Cable Connections and Test Points
(See tables 7-3 and 8-2 for parts identification.)

5. Lift the mechanism out of the unit.

Remove the Power Supply Board

1. Remove the cable that connects the power supply to the main board at connector P1 following this procedure.
 - a. Grasp the connector, *not the cable*, and with the small flat-blade screwdriver pull back one of the locking tabs. While holding back the locking tab, pull up slightly until that side of the connector clears the locking tab.
 - b. Refer to figure 7-10. Insert the screwdriver between the connector and P1, and twist to loosen the connector. Remove the connector.

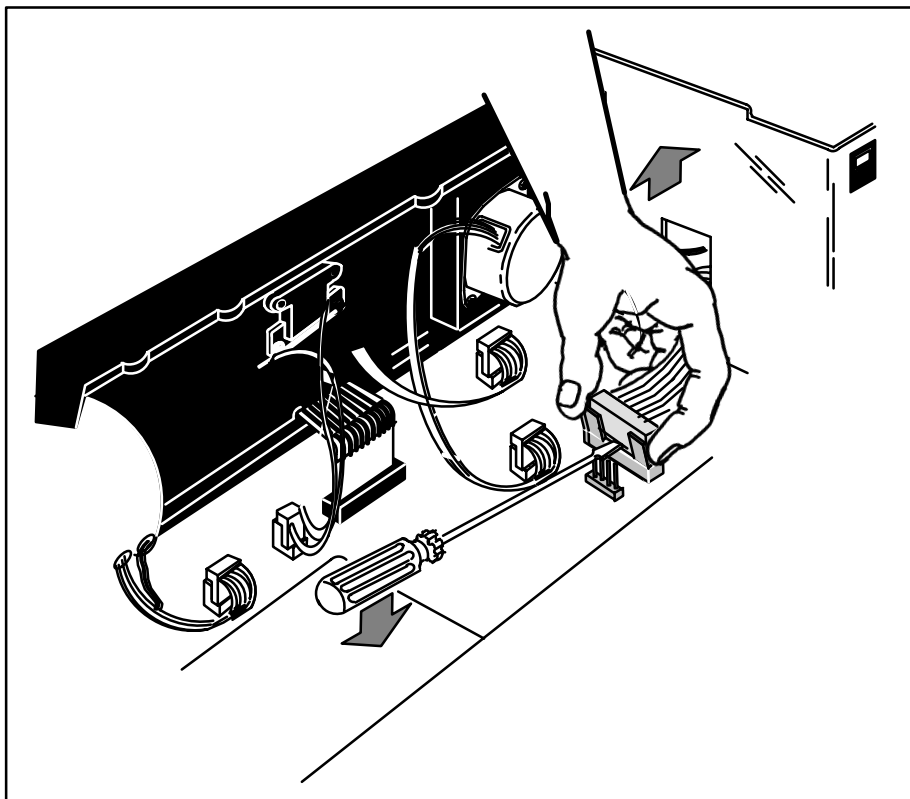

Figure 7-10. DC Cable Removal Detail

2. Remove the ac primary cable that connects the power supply to the line module at connector J1 by releasing the locking tab and pulling out the cable.
3. With the small Pozidriv, remove the two screws that secure the power supply to the metal shield. They are located at the top of the board.
4. Lift the power supply board out of the unit, carefully feeding the cable through the hole in the shield.

Remove the Line Module

1. With the small Pozidriv, remove the two screws that secure the line module to the metal shield. They are located on each side of the power cord socket.
2. With the small Pozidriv, remove the screw attaching the green safety ground wire to the rear panel.
3. Lift the line module out of the unit.

Remove the Cooling Fan

1. Remove the fan cable from the connector on the main PC board by applying slight pressure to the top of the connector to release the locking tab and pull out.
2. Grasp the fan and apply pressure toward the front of the unit and up until the fan clears the locking tabs.
3. Lift the fan out of the unit.

Remove the Main Board

1. Remove the six screws that secure the main PC board to the case and the metal shield. There are three pan-head screws in the rear and four self-tapping screws, two in the front on either side, and two in the middle on either side. Use the small Pozidriv to remove the pan-head screws in the rear and the large Pozidriv to remove the self-tapping screws.
2. Lift the board up from the front and lift it out of the unit being sure to clear the connectors in the rear from the shield.

LIFT THE METAL SHIELD OUT OF THE UNIT.

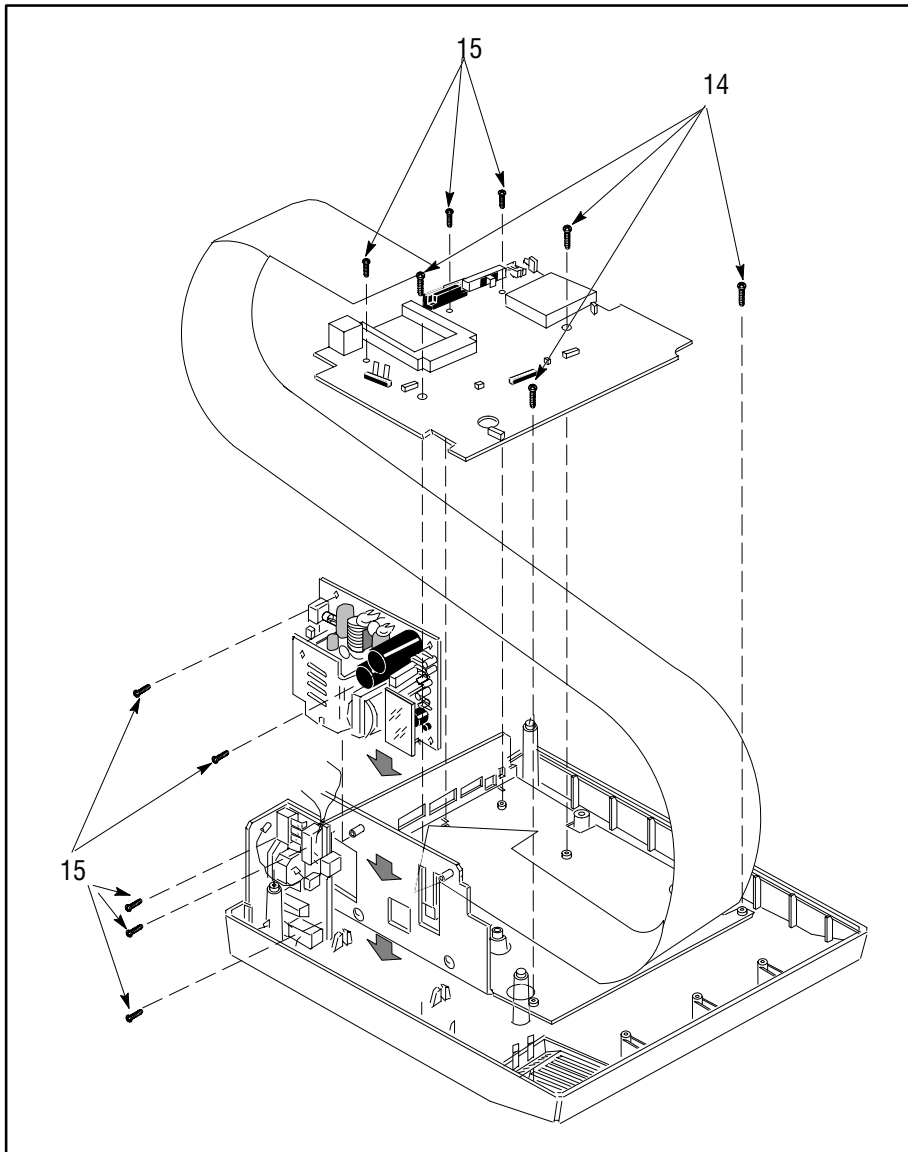

Figure 7-11. Instrument View with Main PC Board Removed
(See table 8-2 for parts identification.)

Diagnostics
Diagnostic Procedures

The unit is now completely disassembled. To reassemble the instrument, follow this procedure in reverse. Refer to figures 7-9, 7-11, and 8-1 for parts and cable placement details. All self-tapping screws should be replaced with new screws.

Diagnostics
Diagnostic Procedures

Replacement Parts 8-2

Cables for Obsolete HP Instruments 8-4

Cable Diagrams 8-5

Power Cable 8-23

Parts and Cables

Parts and Cables

Replacement Parts

Table 1–12. Socketed Components

Item No.	Shown in Figure No.	Description	Reference Description	Part Number
1	8-1	Z-80 ROM	U68	03396-80401
2	8-1	INET ROM	U17	03396-80311

Table 1–13. Other Replacement Parts

Item No.	Shown in Figure No.	Description	Part No.	Quantity
	8-1	Main PC Board	03396-60116	1
8	8-1	Power Supply Module	0950-1884	1
9	8-1	AC Module Assembly	03394-60030	1
10	8-1	Printer Mechanism	03394-61040	1
11	8-1	Keyboard for HP 3396B	03396–60635	1
		Keyboard for HP 3396C	03396–60636	1
		Keyboard for HP 3397	03396–60637	1
12	8-1	Fan	35900-60520	1
13	8-1	Cup Washer	02225-00017	2
14	7-11, 8-1	Screw, Self-Tapping	0624-0427	12
15	7-11	Screw, Machine	0515-0912	8
16	7-9, 8-1	Paper Drive Motor	3140-0787	1
17	7-9, 8-1	Print Carriage Motor	3140-1076	1
–	Not shown	Window	03394-40100	1

Creating the Little Falls Look
German Components

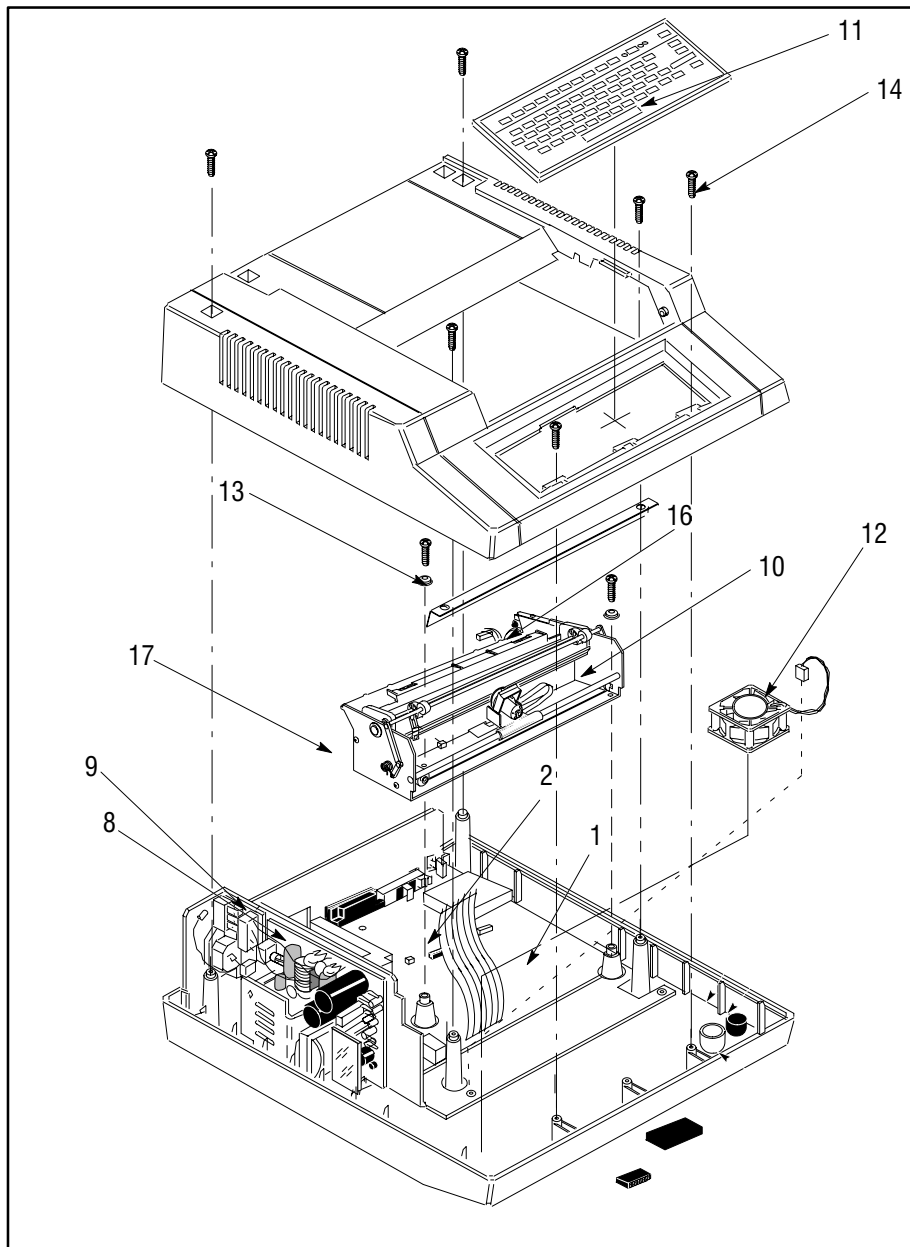

Figure 8-1. Instrument View with Printer Removed (See tables 8-1 and 8-2 for parts identification.)

Cables for Obsolete HP Instruments

Description	Signal Cable	Remote Cable
HP 5710/5730 GC and HP 1081 UV	35900–60620	03396–60620
HP 5880A GC	35900–60570	03394–60540
HP 5790A GC	35900–60590	03396–60620
HP 1040M diode array detector	35900–60600	03396–60650

Reference the HP 3396 Series II Integrator *Reference Manual*, Chapter 8, for the diagrams and pin outs for the cables listed above.

Cable Diagrams

Analog Signal Cables

HP part number 35900-60600 HP 1090A/L LC and HP 1040A Diode Array Detector

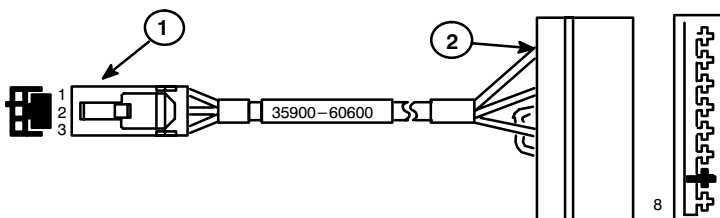

Connector 1—HP 3396	Signal Name	Wire Color	Connector 2—HP 1090 and HP 1040
1	Shield	Orange	1
2	Signal -	Black	5
3	Signal +	Red	3
	Jumper		4,6

HP part number 35900-60610 HP 5890A Gas Chromatograph

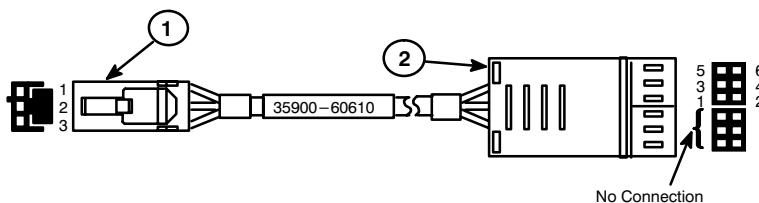

Connector 1—HP 3396	Signal Name	Wire Color	Connector 2—HP 5890
1	Shield	Orange	5
2	Signal -	Black	1
3	Signal +	Red	3

Creating the Little Falls Look
Using this document as an Interleaf template

HP part number 35900-60630 for General Purpose
 Use—Spade Lugs

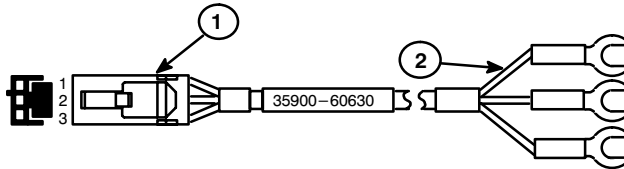

Connector 1—HP 3396	Signal Name	Connector 2—HP 5880 Wire Color
1	Shield	Orange
2	Signal -	Black
3	Signal +	Red

HP part number G1530-60570 for use with
 HP 3395B, 3396C/M, 3397A to HP 6890

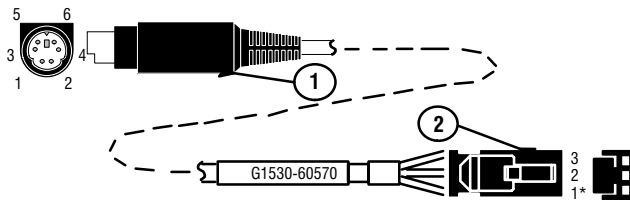

*1 next to triangle etched on connector

Connector 1	Signal name	Color	Connector 2
4	1 V	black	3
2	Common	white	2
Shell	Ground	orange	1

Creating the Little Falls Look
German Components

HP part number 35900-60640
 for Special Purpose Use Square Pins

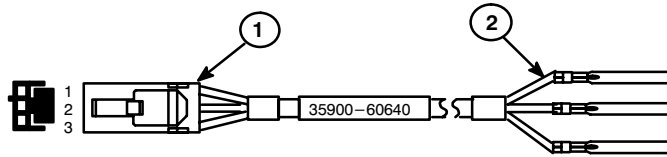

Connector 1—HP 3396	Signal Name	Connector 2 Wire Color
1	Shield	Orange
2	Signal -	Black
3	Signal +	Red

HP part number 35900-60750 HP 1050 Series LC and HP 1046A
 Fluorescence Detector

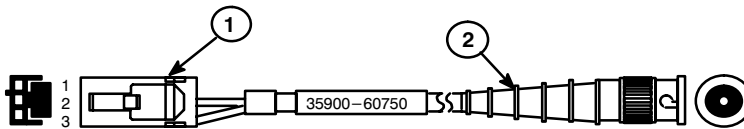

Connector 1—HP 3396	Signal Name	Wire Color	Connector 2—HP 1046
2	Signal -	Black	Shield
3	Signal +	Red	Center

Remote Control Cables

HP part number 03394-60540 HP 3396A/B and HP 3395A
 for General Purpose Use—Spade Lugs

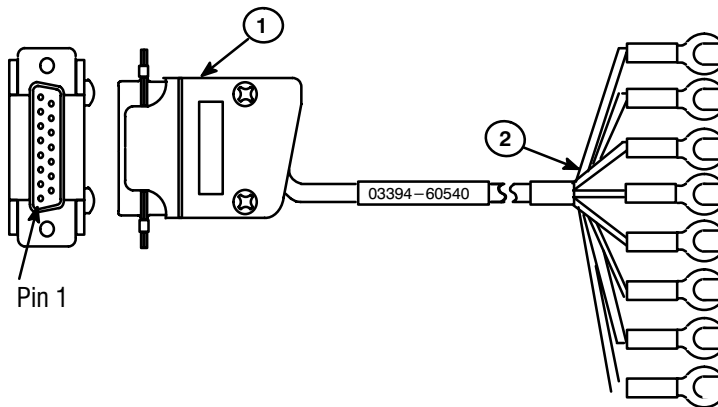

Connector 1 – HP 3396	Signal Name	Connector 2
1	S01	Black
3	START	Green
5	RDY IN	Red
6	STOP	White
13	S02	Orange
14	RDY OUT	Blue
15	GND	Brown
N.C.	DRAIN	Clear

Creating the Little Falls Look
German Components

HP part number 03396-61030 for HP 3396 Series III
 (3396C/M, 3397A, 3395A) for General Purpose Use—Spade Lugs

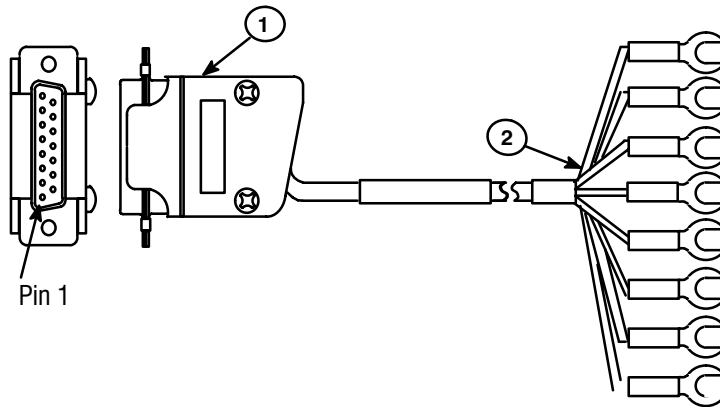

Connector 1 – HP 3396	Signal Name	Connector 2
1	S01	Black
3	START INPUT	Green
4	STOP2	Yellow
5	RDY IN	Red
6	STOP	White
9	GND	Violet
13	S02	Orange
14	RDY OUT	Blue
15	GND	Brown
N.C.	DRAIN	Clear

Creating the Little Falls Look
Using this document as an Interleaf template

Signal Name	Signal Description	Input/Output
SO1	Start Oven 1	Output
START	Start HP 3396	Input
RDY IN	Indicates readiness of system to HP 3396	Input
STOP	Stop HP 3396	Input
SO2	Start Oven 2	Output
RDY OUT	Indicates readiness of HP 3396 to system	Output

SO1 and SO2 are normally open relay contacts that provide a one-second contact closure to start external devices when START is pressed on the HP 3396 Series III.

The proper configuration to start an external device is:

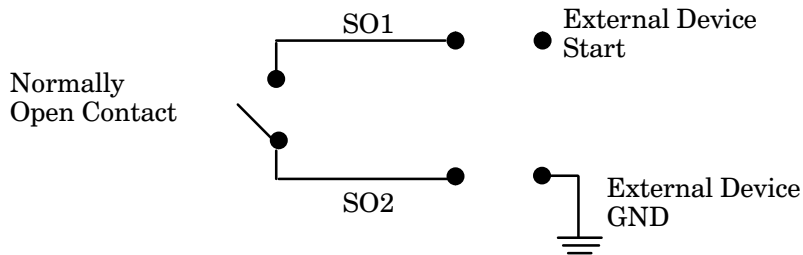

Creating the Little Falls Look
German Components

HP part number 03396-61020
 Cable Pin-Outs, HP 6890A to HP 3396A/B/L Integrator

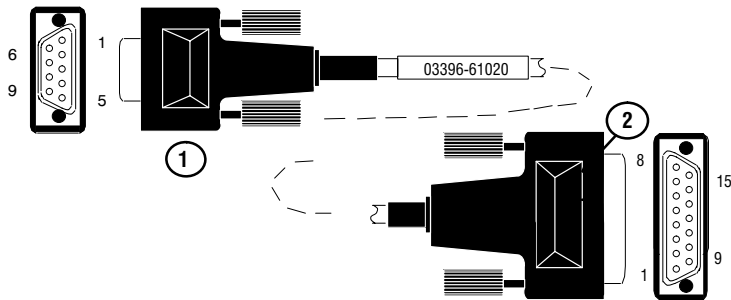

HP 3395A/HP 3396B APG RSS		
Connector 1—9 pin (male)	Signal Name	Connector 2—15 pin (male)
1	GND	9—Ground
2	Prepare	*NC
3	Start	3—Start in
4	Shut down	*NC
5	Reserved	*NC
6	Power on	*NC
7	Ready	14—Ready out
8	Stop	*NC
9	Start request	*NC
*NC = no connect		

Creating the Little Falls Look
Using this document as an Interleaf template

HP part number 03396-61010
 Cable Pin-Outs, HP 6890A to HP 3395B, 3396C/M, and 3397A Integrator

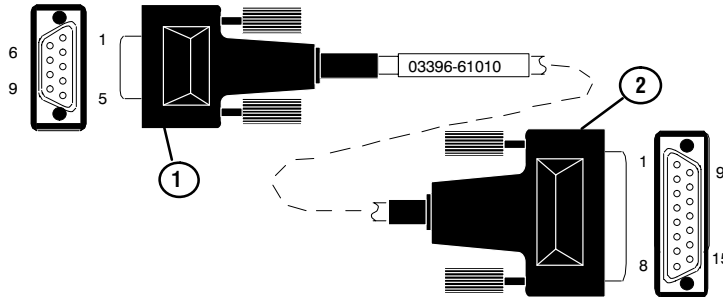

HP 3395B/HP 3396C APG RRS		
Connector 1—9 pin male	Signal Name	Connector 2—15 pin male
1	GND	9—Ground
2	Prepare	*NC
3	Start	3—Start in
4	Shut down	*NC
5	Reserved	*NC
6	Power on	*NC
7	Ready	14—Ready out
8	Stop	4—STOP2 in
9	Start request	*NC
*NC = no connect		

Creating the Little Falls Look
German Components

HP part number 03396-60650
 HP 1090A/L LC and HP 1040A Diode Array Detector

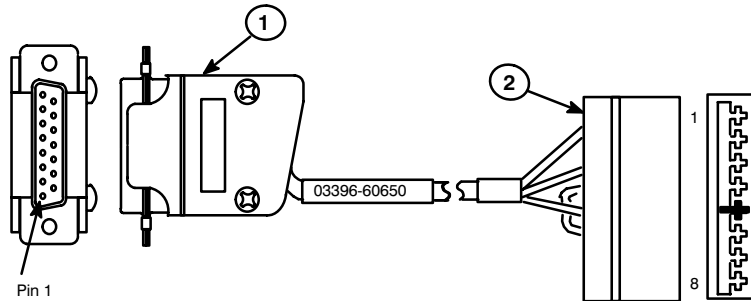

Connector 1—HP 3396	Signal Name	Wire Color	Connector 2—HP 1090
3	START	Red	4
6	STOP	Green	6
15	GND	Black/Orange	1, 8
14	READY	White	3

Creating the Little Falls Look
Using this document as an Interleaf template

HP part number 03394-60560 HP 5890A Gas Chromatograph

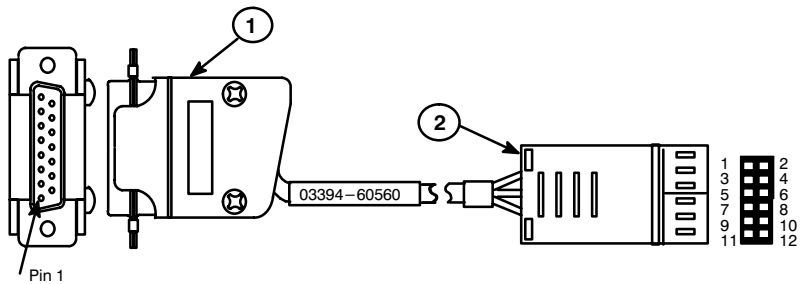

Connector 1—HP 3396	Wire Color	Signal Name	Connector 2—HP 5890
1	Black	SO1	2
3	Green	START	7
5	Red	RDY IN	5
9	Brown	GND	8
13	Orange	SO2	1
15	Clear	GND	N.C.

Creating the Little Falls Look
German Components

HP part number 03394-60600 HP 1046A Fluorescence Detector (APG)

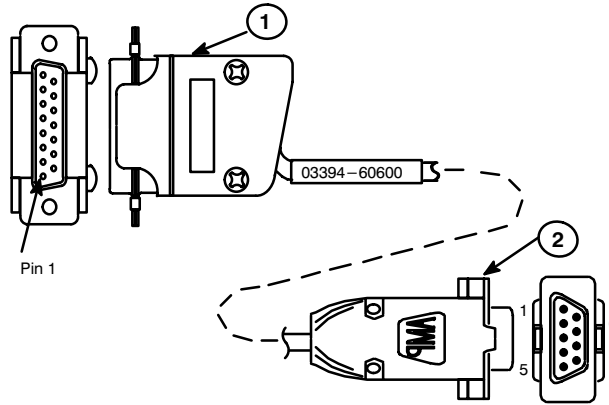

Connector 1—HP 3396	Wire Color	Signal Name	Connector 2—HP 1046
N.C.	Black	<u>START REQ</u>	N.C.
1, 3	Green	<u>START/SO1</u>	3
5, 14	Red	<u>RDY</u>	7
6	White	<u>STOP</u>	8
9	Brown	<u>SIG GND</u>	1
13, 15	Brown/Jumper	<u>SO2, GND</u>	N.C.
N.C.		<u>DRAIN</u>	(To Shell Only)

Creating the Little Falls Look
Using this document as an Interleaf template

HP part number 03396-60550 HP 7673A/B Remote Start/Stop

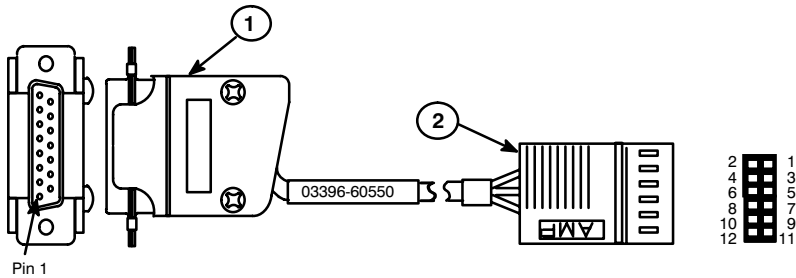

Connector 1—HP 3396		Wire Color	Connector 2—HP 7673	
Pin	Signal Name		Pin	Signal Name
1	SO1	Black	2	GND
3	START IN	Green	7	START OUT 1
5	RDY IN	Red	5	RDY OUT
9	GND	Brown	8	GND
13	SO2	Orange	1	START IN
14	RDY OUT	White	12	RDY IN
15	GND	Drain	3	JMPR TO NO. 4
		Blue	4	JMPR TO NO. 3
		Blue	6	JMPR TO NO. 10
		Brown	10	JMPR TO NO. 6
		Brown		

Creating the Little Falls Look
German Components

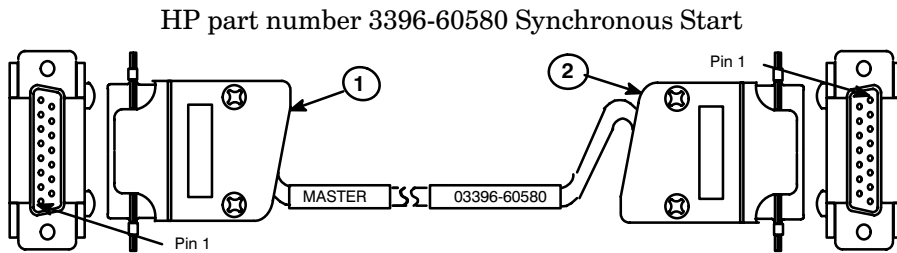

Connector 1—HP 3394/96 Master	Signal Name	Wire Color	Connector 2—HP 3394/96 Slave
1	S01	Black	3
3	START	Green	1
5	RDY/IN	Red	14
9	DRAIN	Clear	9
13	S02	Orange	15
14	RDY/OUT	Blue	5
15	GND	Brown	13

Sample Number Cable

HP part number 03396-60500 General Purpose

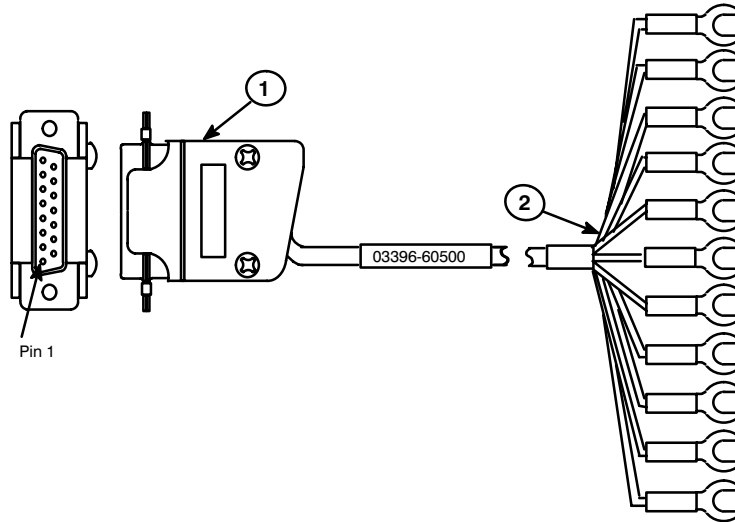

Connector 1-HP 3396	Signal Name	Connector 2—Wire Color
1	BCD 20	Yellow
2	BCD 80	Purple
3	BCD 40	White
4	BCD 10	Orange
5	BCD 1	Brown
6	BCD 8	Green
7	BCD 4	Gray
8	BCD 2	Red
9	GND	Black
10	HITR (High True)	Blue
N.C.	SHIELD	Clear

Connecting pin 10, HITR (high true), to pin 9 (GND) will change the BCD signal from high true to low true.

Creating the Little Falls Look
German Components

HP part number 03396-60560 HP 7673 BCD Sample Cable

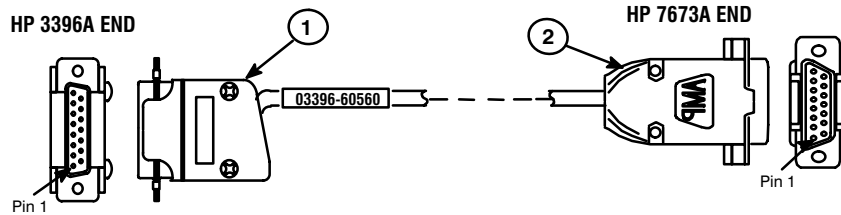

Connector 1—HP 3396	Signal Name	Wire Color	Connector 2—HP 7673
1	BCD 20	Green	1
2	BCD 80	Violet	2
3	BCD 40	Blue	3
4	BCD 10	Yellow	4
5	BCD 1	Black	5
6	BCD 8	Orange	6
7	BCD 4	Red	7
8	BCD 2	Brown	8
9	GND	Gray	9

Creating the Little Falls Look
Using this document as an Interleaf template

HP part number 03396-60580 HP 1090 BCD Sample Cable

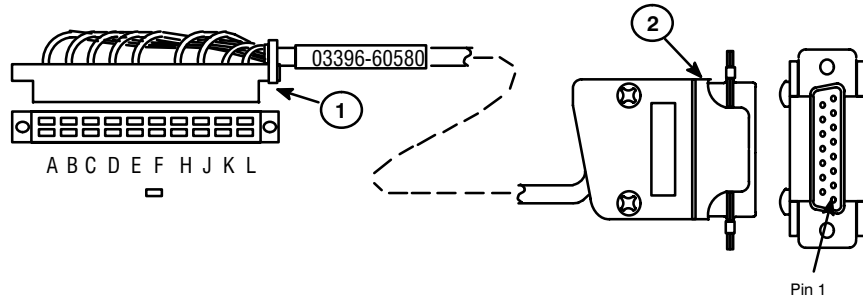

Connector 1—HP 1090	Signal Name	Wire Color	Connector 2—HP 3396
A	GND	Black/Drain	9
B	BCD 80	Violet	2
C	BCD 40	White	3
D	BCD 20	Yellow	1
E	BCD 10	Orange	4
F	KEY	—	—
H	BCD 8	Green	6
J	BCD 4	Gray	7
K	BCD 2	Red	8
L	BCD 1	Brown	5
—	HITR (High True)	Blue	10

Connecting pin 10, HITR (high true), to pin 9 (GND) will change the BCD signal from high true to low true.

RS-232-C Cables

HP part number 03396-60520 DCE Female (25-Pin)

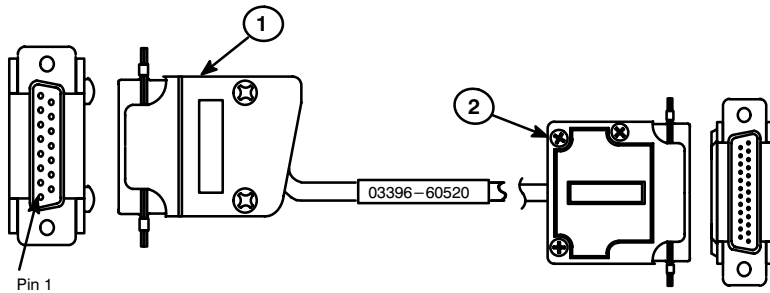

Connector 1—HP 3396	Signal Name	Wire Color	Connector 2— RS-232 Device
1	RLSD	Blue	8
2	RX DATA	Red	2
4, 5	—	Brown Jumper	N.C.
9	SIG. GND	Brown	7
14	TX DATA	Green	3
15	—	White	N.C.
N.C.	RTS/CTS		4, 5
N.C.	DSR/DTR		6, 20
N.C.	PROT. GND		1

Creating the Little Falls Look
Using this document as an Interleaf template

HP part number 03396-60510 DTE Male (25-Pin)

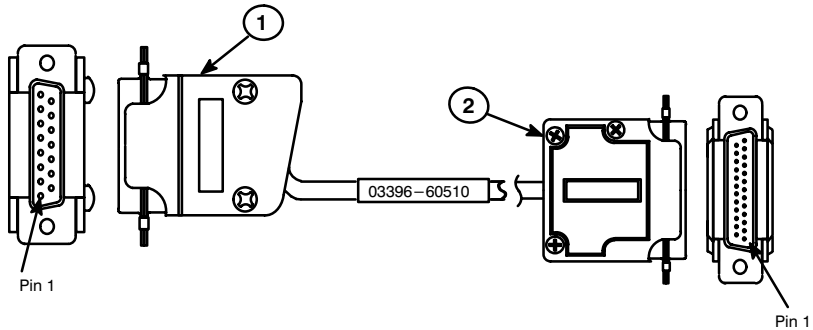

Connector 1—HP 3396	Signal Name	Wire Color	Connector 2— RS-232 Device
1	RTS	Blue	4
2	RX DATA	Red	3
4, 5	—	Brown Jumper	N.C.
9	SIG. GND	Brown	7
13	CTS	Orange	5
14	TX DATA	Green	2
15	—	White	N.C.
N.C.	PROT. GND		1

Creating the Little Falls Look
German Components

HP part number 03396-60530 DCE Female (9-Pin)

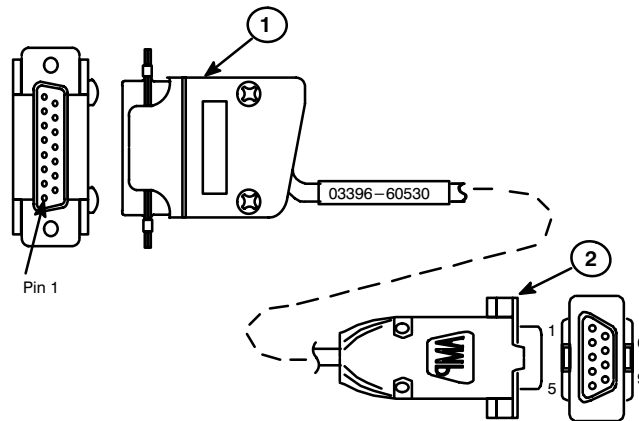

Connector 1—HP 3396	Signal Name	Wire Color	Connector 2— RS-232 Device
1	RLSD	Red	1
2	RX DATA	Green	3
4, 5	—	Brown	N.C.
9	SIG. GND	Black	5
14	TX DATA	White	2
15	—	White/Yellow	N.C.
N.C.	RTS/CTS		7, 8
N.C.	DSR/DTR		6, 4
N.C.	PROT. GND		N.C.
			(To Shell Only)

Power Cable

Part Number	Source Voltage	Voltage Setting	Predominant Country of Usage
8120-1378	120 V ac 100 V ac 220 V ac	115 115 230	USA and Canada Japan Israel
8120-1369	240 V ac 220 V ac	230 230	Australia New Zealand
8120-1689	220 V ac	230	European Continent
8120-1351	240 V ac	230	United Kingdom

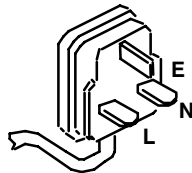
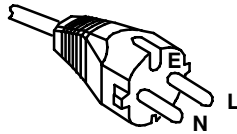
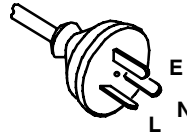
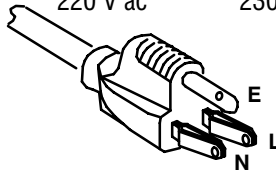

Creating the Little Falls Look
German Components

Part Number	Source Voltage	Voltage Setting	Predominant Country of Usage
8120-0698	240 V ac	230	USA and Canada
8120-2104	220 V ac	230	Switzerland
8120-2956	220 V ac	230	Denmark, Greenland
8120-4211	240 V ac	230	India, South Africa

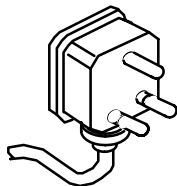
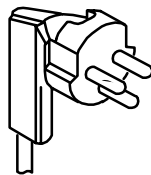
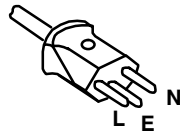
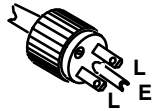

Creating the Little Falls Look
Using this document as an Interleaf template

What Devices Communicate with the Integrator? 9–2

Using Non-INET Analytical Instruments 9–3

Communicating
with Other Devices

Introduction

What Devices Communicate with the Integrator?

The HP 3396 integrator communicates with a variety of devices through its back panel receptacles.

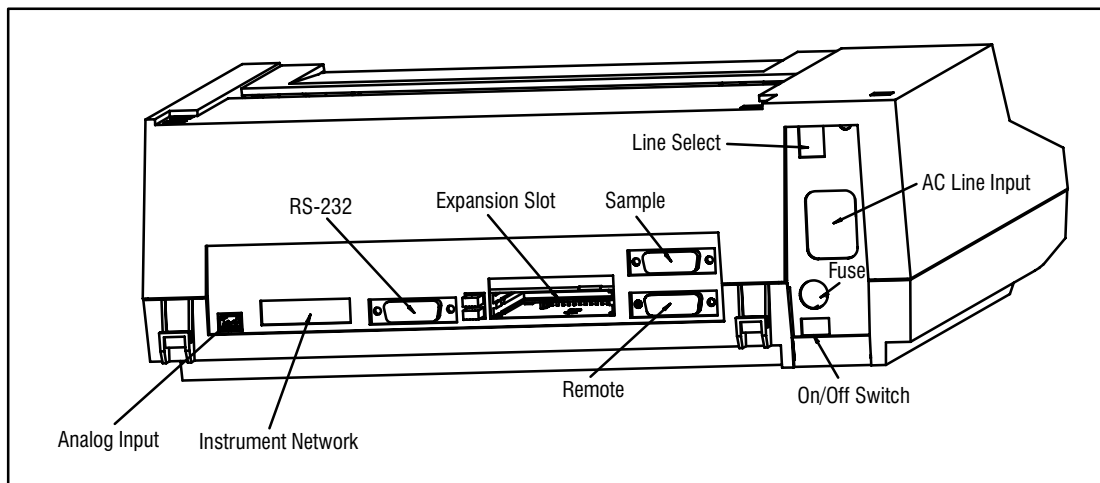

Device Type	Interface Type	Back Panel Receptacle	See Chp
HP networking analytical instruments	INET	INSTRUMENT NETWORK	10
Non-INET analytical instruments	Analog	ANALOG INPUT	9
	TTL	REMOTE	9
	BCD	SAMPLE	9
Disk drives	HP-IL and HP-IB*	INSTRUMENT NETWORK	10,11
HP-IL/HP-IB Interface (HP 82169A)	HP-IL	INSTRUMENT NETWORK	10
Host computer	RS-232-C	RS-232-C	12
Modem	RS-232-C	RS-232-C	12

*Requires HP 82169A HP-IL/HP-IB Interface

Using Non-INET Analytical Instruments

The HP 3396 integrates analog input between -10 mV and $+1000$ mV.

Use the appropriate Analog Signal cable to connect an analytical instrument not part of Hewlett-Packard's instrument network to the analog input receptacle of the HP 3396. See the *Reference Manual* for installation information.

NonINET analytical instruments must be started and stopped manually unless the Remote Control cable is used. Sample numbers are transmitted from nonINET instruments through the Sample Number cable.

Using the Remote Control Cable

A Remote Control cable allows the integrator

- to start other instruments
- to be started and stopped by other instruments
- to provide readiness status to other instruments.

Since remote control signals are exchanged over the Instrument Network (INET), a Remote Control cable is not usually needed when INET is installed.

Note: Since both INET and the Remote Control cable supply readiness status, any instrument connected to the HP 3396 via INET should not directly or indirectly connect its READY output to the HP 3396's READY input via the Remote Control cable.

The Remote Control cable start output is connected to the start input of an analytical instrument such as a gas chromatograph (GC). The READY line in the cable may be connected to a signal from the GC that indicates oven readiness. In this case, when you press **[START]** on the HP 3396, the integrator is started, and so is the oven program on the GC. If the oven or the integrator is not ready, the message “not ready” is printed at the start of the run. The integrator processes the signal anyway; the message serves only to caution you that something is not ready.

See the HP 3396 *Reference Manual* for related information.

Using the Sample Number Cable

The Sample Number cable allows the HP 3396 to accept binary coded decimal (BCD) sample (bottle) number data from an automatic sampler or sequencer. Since sample number data are exchanged over INET, a sample number cable is usually not needed when INET is installed. See chapter 10, *Using the Instrument Network* for a more detailed explanation.

Further information about how to automate a series of analyses using the Sample Number cable can be found in the *Automating Analyses* chapter of the HP 3396 *Operating Manual*.

See the Installation and Service sections of this manual for related information.

What is the Instrument Network?	10-2
Starting and Stopping INET	10-3
Checking for Instrument Readiness	10-5
Listing INET Devices	10-6
Controlling INET Instruments with the HP 3396	10-9
Controlling the HP 6890	10-16
Understanding INET	10-17

Using the Instrument Network

Using the Instrument Network

What is the Instrument Network?

Hewlett-Packard's analytical Instrument Network (INET) provides a data, parameter, and command path for analytical instruments to communicate with each other. The Hewlett-Packard Interface Loop (HP-IL) provides a path for this communication. The following table lists the INET instruments that are compatible with the HP 3396 at the time of this printing.

INET Instruments Compatible with the HP 3396

Device Type	Model Number	Comments
INET GC	HP 5890A HP 6890A HP 5890 Series II	Rev C or later software.
INET LC	HP 1090L HP 1050	Rev B2616 or later software is compatible with the HP 3396.
INET Sampler	HP 7673	Automatic sampler.
INET Sampler/Event Control Module (S/ECM)	HP 19405A	Used with nonINET Samplers, HP 7670/71/72A and to control automated GC valving.
INET INTEG Event Control Module (IECM)	HP 19405B	Used with INET instruments to control external events.

Starting and Stopping INET

When INET is enabled, runs may be started from any INET instrument by pressing [**START**]. All INET instruments will start at the same time, coordinated by communication over the network. When starting sequences on INET, the HP 7673 will begin its pre-run activity before starting the HP 5890 or HP 6890 and the associated integrator.

Pressing [**STOP**] on any INET instrument stops the current run, and aborts a sequence if one is running.

When the HP 6890 GC is part of the instrument configuration, the HP 6890 and HP 3396 communicate over INET, but the HP 6890 and the HP 7673 Sampler communicate over RS-232. The HP 3396 does not communicate with the HP 7673 Sampler; the sampler is controlled by the HP 6890.

When the HP 5890, HP 7673, and HP 3396 are configured, they all communicate over INET and the HP 3396 controls the sampler.

See *Automating Analysis*, in Chapter 9 of the HP 3396 *Operating Manual* for related information.

Hewlett-Packard's Instrument Network (INET)

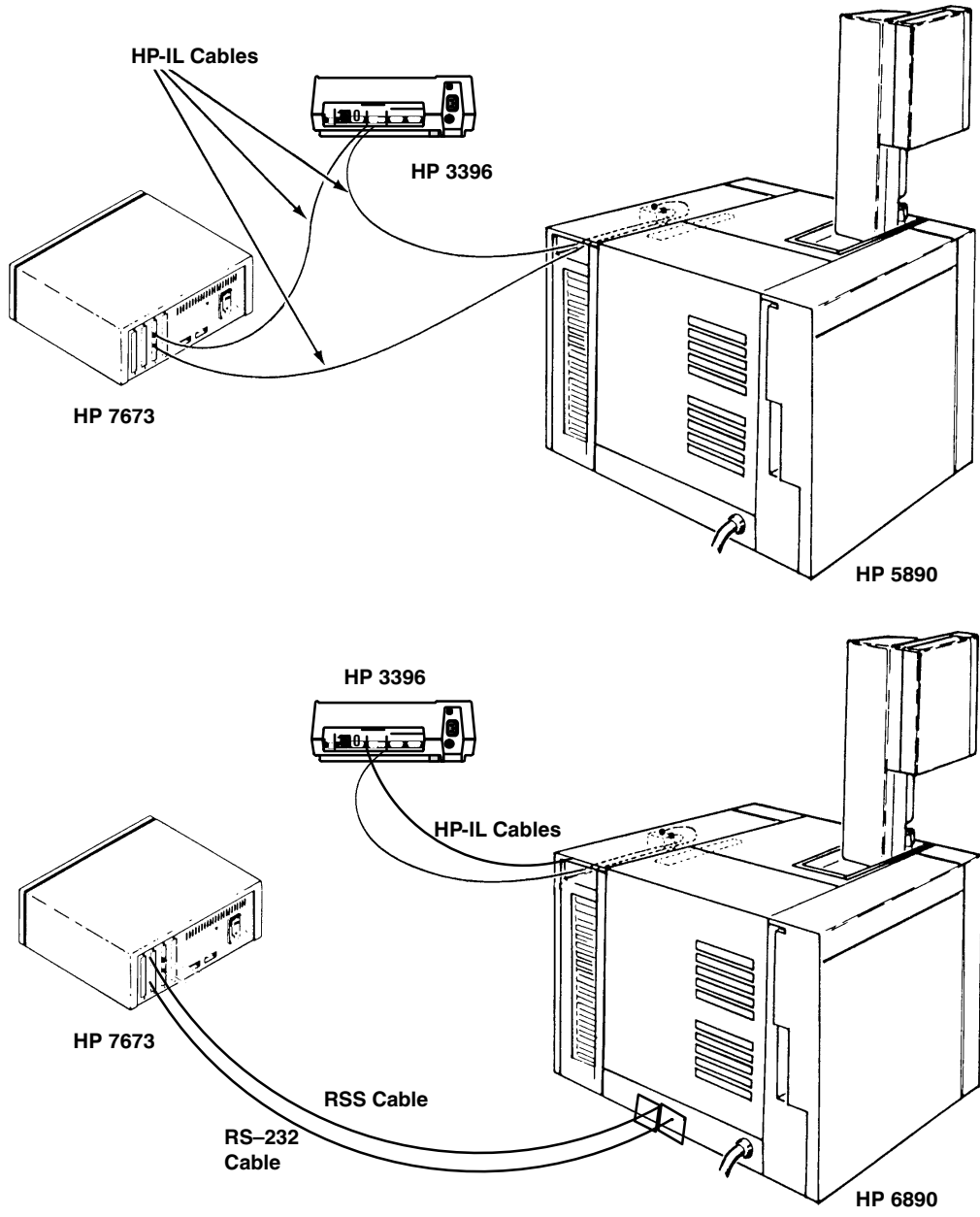

Checking for Instrument Readiness

All INET instruments, the HP-IL disk drives, and instruments that use the READY line in the Remote Control cable can be checked for readiness by the HP 3396.

The green READY indicator on the keyboard indicates readiness for the HP 3396 and all INET instruments that are connected and turned on.

1. Type [R] [E] [A] and press [ENTER] to check system readiness.

If the HP-IL loop is “UP” (all cables connected, all instruments switched on), and if all INET instruments and HP-IL disk drives are ready, the HP 3396 prints `SYSTEM IS READY`. (The HP 3396 checks the readiness of the disk drives only when file storage is enabled via option 2 or option 5.)

The Remote Control cable ready line is also checked for a ready state if it is being used.

If the HP-IL loop is “DOWN” (a broken connection, or instruments powered OFF), the HP 3396 assumes you are not using it, and reports that all is ready as above. To avoid being misled if you don’t know whether the loop is down, use the **SYSTEM** command [S] [Y] [ENTER]. The HP 3396 will print `Loop is down` instead of the `LOOP CONFIGURATION TABLE` if the loop is not active.

During sequence operation the readiness check is performed automatically, and the HP 3396 waits for system readiness before starting each run in the sequence. However, when you start a run manually, the HP 3396 will not automatically check readiness. When the system is not ready and a run is started manually, the run will proceed after warning you that the system is not ready by printing `START; not ready`.

Listing INET Devices

With the HP 3396 in system command mode, a user can get a listing of the INET Configuration Table. This command can be abbreviated by its first two characters.

1. **Type [I] [N] and press [ENTER] to get a listing of the INET Configuration Table.**

The routing of INET data from producers to consumer is referred to as a *data path* in the table. Data paths are automatically configured when the instrument is switched on, but may also be changed manually from the HP 3396 keyboard.

Example

```
*      I  N      [ENTER]
LIST, EXIT, CHANGE, OR HELP [L/E*/C/H]:      L      [ENTER]
                INET CONFIGURATION

```

<u>ENTRY</u>	<u>MODEL</u>	<u>ADDR</u>	<u>DATA PATH</u>	<u>STATUS</u>
1	3396C	0	C1 CONS CH 0	ACTIVE
2	6890A	8	C1 PROD CH 0	ACTIVE
3	6890A	8	C1 PROD CH 1	IDLE
4	3396C	0	K0 PROD CH 0	ACTIVE
5	6890A	8	K0 CONS CH 0	ACTIVE
6	3396C	0	R0 CONS CH 0	ACTIVE
7	6890A	8	R0 PROD CH 0	ACTIVE
8	6890A	8	R0 PROD CH 1	IDLE
9	6890A	8	R0 PROD CH 2	ACTIVE
10	3396C	0	S0 CONS CH 0	ACTIVE
11	6890A	8	S0 PROD CH 0	ACTIVE
12	6890A	8	S0 PROD CH 1	IDLE

```
LIST, EXIT, CHANGE, OR HELP [L/E*/C/H]:      [ENTER]
```

Creating the Little Falls Look
German Components

The configuration table below is a typical listing with an HP 19405B IECM and HP 6890 on the INET loop; the HP 6890 is configured to an HP 7673 with an RS-232 cable. Your configuration table may be slightly different. The DESCRIPTION column explains what data each path transmits.

<u>ENTRY</u>	<u>MODEL</u>	<u>ADDR</u>	<u>DATA_PATH</u>	<u>STATUS</u>	<u>DESCRIPTION</u>
1	3396B	0	A0 CONS CH 0	ACTIVE	HP 3396 receives external event data run annotation.
2	D3C-IECM	10	A0 PROD CH 0	ACTIVE	IECM produces external event run annotation.
3	3369C	0	C1 CONS CH 0	ACTIVE	HP 3396 receives signal data.
4	6890A	8	C1 PROD CH 0	ACTIVE	GC signal 1 produces signal data.*
5	6890A	8	C1 PROD CH 1	IDLE	GC signal 2 produces signal data.*

Only one signal producer can be active at a time. The channel that is not active is buffered, and can be analyzed using the Dual Channel Applications Program, or the ANALYZE Q: command. See *The Buffered Channel*, in the Appendix.

6	3396C	0	I1 PROD CH 0	ACTIVE	HP 3396 tells the IECM when to open or close a switch.
7	D3C-IECM	10	I1 CONS CH 0	ACTIVE	IECM receives information on switches.
8	3396C	0	K0 PROD CH 0	ACTIVE	HP 3396 receives command data.
9	6890A	8	K0 CONS CH 0	ACTIVE	GC produces command data.
10	3396C	0	R0 CONS CH 0	ACTIVE	HP 3396C receives report annotation data.
11	6890A	8	R0 PROD CH 0	ACTIVE	GC produces front bar code data for reports.*
12	6890A	8	R0 PROD CH 1	IDLE	GC produces rear bar code data for reports.*
13	6890A	8	R0 PROD CH 2	ACTIVE	GC produces run log data for reports.

Creating the Little Falls Look
Using this document as an Interleaf template

14	3396C	0	S0	CONS	CH 0	ACTIVE	HP 3396 receives sample number data.
15	6890A	8	S0	PROD	CH 0	ACTIVE	GC produces front injector sample number data.*
16	6890A	8	S0	PROD	CH 1	IDLE	GC produces rear injector sample number data.*
17	D3C-IECM	10	S0	PROD	CH 0	IDLE	IECM produces sample number external event data.

*The front and rear assignments for bar code information and sample number data, and signal 1 and signal 2 positions for signal data, are shown in this table in their default positions. The default positions can be changed by the user; see the Appendix.

Controlling INET Instruments with the HP 3396

The HP 5890, HP6890, and HP 7673 series samplers can execute commands sent from the HP 3396 using K0 data path transactions. Each of these instruments has a set of response messages that are returned to the HP 3396 as a result of executing a command.

The HP 5890 has a keycode corresponding to each key on its keypad. By combining keystrokes on the keypad of the HP 3396, command strings can be sent as if the commands were entered on the keypad of the HP 5890.

The HP 7673 series samplers use abbreviations to control each parameter. The abbreviated words are entered with the alphanumeric keys on the HP 3396. Some commands are common to all HP 7673 samplers. There is an expanded command set for the HP 7673C to accommodate its greater functionality.

The tables on the following two pages show the abbreviations and keycodes for these instruments.

Because it is a much more sophisticated instrument, the HP 6890 has a more elaborate command set and uses a different logic to implement it. See the HP 6890 *Programmers Manual* for complete information.

Example To enter an oven temperature of 250°C at the HP 5890's keypad, you would press **[OVEN] [TEMP] 250 [ENTER]**

The command string for this set of key sequences is **KEY:G250@** where **KEY:** is the command for keypad entries.

1. **Press [OP()] [6] [ENTER] to send a K0 command string.**

This dialog may also be accessed through section 8 of the **[EDIT] [METH]** dialog. Whichever way the dialog is accessed, the syntax for entering commands remains the same and the HP 3396 responds with

DEVICE ADDRESS:

2. **Press [10] [ENTER] to enter the loop address of the HP 5890.**

This address is printed in the INET Configuration Table which is accessed by pressing **[I] [N] [ENTER]**. After entering the address of the intended consumer, the HP 3396 will prompt for a command string with

COMMAND STRING:

3. **Type KEY:G250@ to set the oven temperature on the HP 5890 to 250°C.**

The command string entered at this point depends on the instrument receiving the command and your purpose. A partial list of commands, which represent set points for the HP 7673, can be found on the next two pages.

See *Understanding INET* later in this chapter for related information.

INET_I/O Commands for HP 5890A and HP 5890 Series II

HP 5890 Key	Keycode	HP 5890 Key	Keycode
STOP	=	CLEAR	?
START	^	0	0
OVEN TEMP	G	1	1
INIT TEMP	H	2	2
INIT TIME	I	3	3
RATE	J	4	4
FINAL TEMP	K	5	5
FINAL TIME	L	6	6
INJ A TEMP	M	7	7
INJ B TEMP	N	8	8
DET A TEMP	O	9	9
DET B TEMP	P	.	.
OVEN MAX	Q	-	-
EQUIB TIME	R	gold key	/
SIG 1	V	TABLE	/H
SIG 2	W	ADD	/I
RANGE	X	DELETE	/J
ZERO	Z	PREVIOUS	/K
ATTN	Y	NEXT	/L
DET	>	INJ A PRES	/M
ON	E	INJ B PRES	/N
OFF	F	OVEN TRACK	/O
A	A	AUX TEMP	/P
B	B	FLOW PARAM	/S
COL COMP 1	C	CRYO PARAM	/S
COL COMP 2	D	STORE	/V
FLOW	S	LOAD	/W
PURGE	U	TCD SENS	/>
TIME	T	to check ROM version	;
ENTER	@	super clear	:

HP 7673 INET_I/O Commands

HP 7673 Command	Command Abbreviation
INJECTIONS/BOTTLE	INJ
FIRST BOTTLE	FIRST
LAST BOTTLE	LAST
SAMPLE WASHES	WASH
PUMPS	PUMP
VISCOSITY	VIS
INJECTION VOLUME	VOL
A WASHES	AWASH
B WASHES	BWASH
PRIORITY SAMPLE	PRI
ON-COLUMN	ONCOL
BOTTLE	BOT
POSITION	POS
MOVE	MOV
MANUAL SEQUENCE	MAN
AUTO SEQUENCE	AUTO
RETURN BOTTLES	RET
TURRET	TUR
RESET	RES
VERSION	VER
ERROR	ERR
TRAY	TRY
BAR CODE READER	BCR

Controlling the HP 5890 through BASIC

The following BASIC program uses the **INET_IO** command and the command string listed above to set the oven temperature to 250°C at the HP 5890 located at INET address 8. For this program to execute properly, the HP 3396 must be configured as a K0 producer and the HP 5890 as a K0 consumer. See *Understanding INET* later in this chapter for instructions on how to change the INET Configuration Table.

```
10 !This program sets HP 5890 GC OVEN TEMP to 250
20 !First dimension a command string (GCOP$) for the
   appropriate
30 !keystrokes and a response string (GCRESP$) for the GC's
   response
40 DIM GCOP$(22), GCRESP$(80)
50 !Enter the command string
60 GCOP$ = "KEY:G250@"
70 !Transmit the command to device address via INET
80 INET_IO 8, GCOP$, GCRESP$
90 PRINT GCRESP$
100 END
```

This program directs the HP 3396 to print the instrument's response to the command sent to it. The response printed by the HP 3396 might look like this:

```
AOVEN      TEMP      50      250
```

In this case, the "A" indicates that the HP 5890 has acknowledged the new oven temperature set point. The current value of the oven temperature is listed next, followed by the new set point. Attempting to set the oven temperature to 500° C, however, elicits the following response:

OVEN LIMIT = 400

Any combination of keys that is valid on the keyboard can be replicated using the INET_I0 command. When an invalid key sequence is entered, the CLEAR keycode must be sent to clear the error and go on, just as it is done at the instrument keypad. Refer to the Operator's Quick Reference Card and the HP 5890 *Reference Manual* for a list of valid key sequences for the HP 5890.

Controlling the HP 7673 through BASIC

When the HP 7673 is part of the INET configuration, commands are sent via INET to control in the same way they are sent to the HP 5890. However, since the HP 7673 does not have a keypad, the sampler commands duplicate all the set points accessible through the HP 3396 sequence dialog. Unlike the HP 5890, the HP 7673's message strings are composed of a set point keyword and a value for either or both the front and rear injectors. A complete list of keycodes for the HP 7673's sampler parameters are located earlier in this section. The syntax for each sampler command is the same. The table below uses the INJECTIONS/BOTTLE command to illustrate the sampler command syntax.

Command String Syntax for the HP 7673

Command String Syntax	Action Taken by HP 7673
INJ	Returns current set points
INJ2,3	Injector 1 will do 2 injections per bottle. Injector 2 will do 3 injections per bottle.
INJ,1	Injector 1 will use its current setting. Injector 2 will do 1 injection per bottle.
INJ3	Injector 1 will do 3 injections per bottle. Injector 2 will use its current setting.

When the HP 7673 acknowledges a set point, the HP 3396 prints the current set point values separated by a comma, for the front and rear injectors. If only one injector is installed, the set point will be repeated twice. If only one injector's set point is changed, the previous set point value for the other injector is retained and printed. When the sampler command string causes an error, then the sampler will print "N" and an error message. If a keycode is sent to a different instrument at the wrong address, the HP 3396 may print:

```
ADDRESS IS NOT ON LOOP OR DOES  
NOT SUPPORT K0 DATA PATH
```

Example

The BASIC program below illustrates how to send commands to a dual injector HP 7673 to control the number of pumps done by the front and rear injectors. The HP 3396 must be configured as a K0 producer and the HP 7673 as a K0 consumer. See *Understanding INET* later in this chapter for instructions on how to change the INET Configuration table. The HP 7673 in this example is at INET address 9.

```
10 !Set HP 7673A front injector to do 5 pumps per sample and
20 !the rear injector to do 2 pumps per sample
30 !SAMPOP$ = command string
40 !SAMPRESP$ = response string
50 DIM SAMPOP$(22), SAMPRESP$(80)
60 !Enter the command string
70 SAMPOP$ = "PUMPS5,2"
80 INET_IO 9, SAMPOP$, SAMPRESP$
90 PRINT SAMPRESP$
100 END
```

This program directs the HP 3396 to print the INET sampler's response to the PUMP command string. If the sampler accepts the new set point, it might respond with:

```
A 5, 2
```

If, however, the command is rejected by the sampler, it responds with:

```
N error message
```

Controlling the HP 6890

The HP 6890 can be controlled using the K0 data path, and through BASIC, in the same manner as the HP 5890. The command structure is different. For further information, see the *HP 6890 Programmers Manual*.

Understanding INET

HP-IL, the Hewlett-Packard Interface Loop, is a serial two-wire connection and a software protocol that allows printers, storage devices, and analytical instruments to communicate with each other. INET instruments are Hewlett-Packard samplers and gas chromatographs that operate with the HP 3396 on the HP-IL. INET devices use HP-IL protocol to exchange information.

INET is a communications application of HP-IL that controls analytical instrumentation. Where HP-IL protocol allows printers and disk drives to communicate with the HP 3396A, INET provides a data and command path for analytical instruments to operate effectively together. Implicit in the network are protocol and data structures that allow a group of instruments comprising a controller, data producers, and data consumers to function as a single system. Each INET device is an HP-IL device with an extra layer of software for more sophisticated operation. INET is controlled locally by the HP 3396 or remotely controlled by a host computer when an integrator is not used.

Since INET instruments use the HP-IL interface, much of the physical operation is also the same as HP-IL. The HP-IL-based network has one controller and a number of talkers and listeners. The HP 3396 is the HP-IL controller. Producers send messages over the loop and consumers receive messages. INET's producers and consumers are divided further into "objects" (or instrument functions) that produce and consume different types of chromatographically meaningful data.

Each INET instrument stores its own set points and parameters and also makes them available to the HP 3396, for listing and remote storage. The collection of these storage areas is the active workspace of the HP 3396 system. The active workspace will expand and contract as instruments are added or removed from the network. However, while the HP 3396 is being operated, the active workspace always appears to be a single, contiguous, yet distributed piece of information.

A typical INET system is illustrated below.

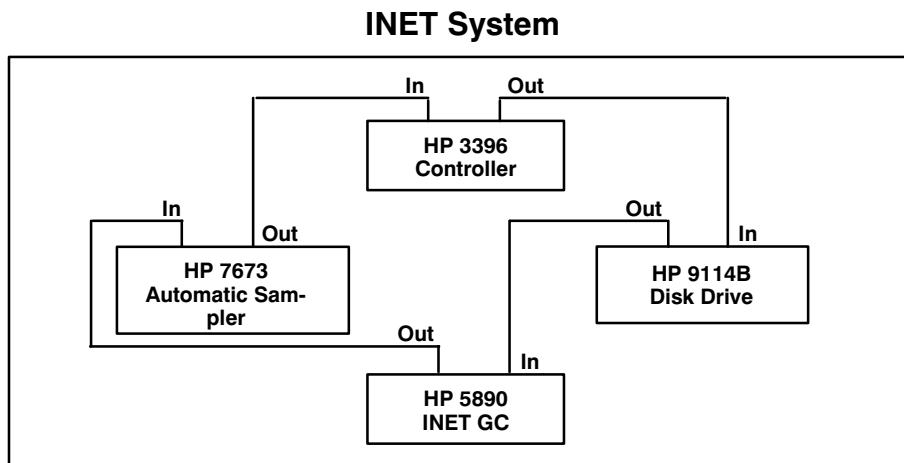

As stated before, INET adds another layer of software protocol to HP-IL so that analytical instruments can communicate with each other as well as with other HP-IL devices. Since INET devices must conform to HP-IL standards, both types of instruments are compatible on the same loop with one HP 3396 acting as controller for both analytical and HP-IL devices.

Controlling INET Devices

The HP-IL interface and INET protocol allow the HP 3396 to receive and control INET instrument set points. The set points are encoded ASCII character strings and are grouped in blocks in the active workspace with the INET (loop) address of the instrument to which they belong. These strings are transmitted to the HP 3396 over the HP-IL/INET link during configuration. The HP 3396 can also pass set points between INET instruments (including itself) and local or computer storage. For example, the **[STORE] [METH]** key sequence initiates the passing of set point blocks from the network instruments to the HP 3396. Once these keys are pressed at the HP 3396 keyboard, all set point traffic is automatic.

If the network is broken and then reconnected in a different order, the address of a particular instrument may change. However, since the HP 3396 tries to load set points to the loop using model numbers as addresses, each instrument will still get the correct set point block as long as there are no other instruments with the same model number on the loop.

The HP 3396 only discriminates between instruments with the same model number by their physical location. Set points from a method saved prior to the break may be sent to the wrong instrument. If two instruments with identical model numbers are on the same loop and their positions are switched *after* a method has been stored, each will receive the set points intended for the other when the method is reloaded into the active workspace. However, INET instruments will not accept set points with parameter value errors (e.g. an HP 19405B will reject HP 5890 parameters).

In addition to accepting keyboard entry for its own set points, in certain cases the HP 3396 provides keyboard entry of set points for other INET devices. The **[PREP] [SEQ]** dialog allows set points to be chosen for the HP 7673 sampler when an HP 5890 is configured, or the HP 19405B IECM (INTEG Event Control Module). The HP 7673 sampler and HP 5890 GC set points may be entered via option 6, the **[PREP] [METH]** dialog, or through INET_I0 statements in a BASIC program. The HP 3396 may alter set points before or after a run but not while a run is in progress. Specific instructions for how to enter set points for INET instruments from the HP 3396 are described in earlier in this chapter.

INET Operating States

As the instruments exchange commands under the direction of the HP 3396, INET moves through its five distinct operating states.

INET Operating States

Network State	Typical HP 3396 Mode or Activity
Inactive	Waiting for commands
Prerun	Waiting for sampler to find bottle, doing pumps, washes, etc.
Run	Integration mode
Postrun	Calculation and report generation
“Run may not begin”	Plot mode, BASIC mode, during an ANALYZE , an open dialog, or threshold measurement. Also if the host computer explicitly requests the “run may not begin” state, or during a column compensation run on the HP GC.

INET states are characterized by the type of HP 3396 activity as well as the kinds of data transmissions that are taking place. The steps outlined below illustrate how an HP 3396 and an active sampler would typically proceed through different network states as they carry out a sequence of runs.

1. **Inactive state:** The network instruments are ready; the user then presses [**SEQ**] [**START**] on the HP 3396 keyboard. The HP 3396 issues a command to change the network state to the Prerun state.
2. **Prerun state:** The sampler begins searching in its sample tray for the bottle specified in its sequence. When it finds the bottle, it makes an injection and issues a command for INET to enter the Run state.

3. **Run state:** The HP 3396 enters INTEGRATION mode. When the run ends (for example, when a Timetable STOP command occurs), the HP 3396 sends a message on the network to change the network to the Postrun state.
4. **Postrun state:** During this state, the HP 3396 calculates the result of the previous run and prints its report. It calls for any report annotations other instruments wish to add, and it appends them to the end of the report. (The report may be printed or written to a file.) The HP 3396 also stays in the postrun state while the HP 6890 is executing any postrun programs.
5. The next state change depends on the sampler. If the sampler is finished, it directs the network to the Inactive state (1). If it is not finished with its sequence, it directs the network to the Prerun state (2). The sampler advances to the next sample to be injected and INET operation continues from there.

Automatic Network Configuration

Data paths connect data producers to data consumers of matching type and format. INET automatically configures data paths among all of the instruments on the loop. Certain objects allow only one consumer or producer, while other data types may allow multiple consumers and producers.

When an active data producer puts data out on the loop, the active consumers of that type of data accept it automatically. For example, an active INET sampler (e.g. HP 7673 when configured to an HP 5890 GC) produces sample numbers on the loop. The HP 3396 is an active consumer of sample numbers. It prints the sample number from the sampler in the upper right hand corner of the report for that run and also searches its sample table for a match to the sample number.

Before the configuration process is begun, the HP 3396 determines whether to initiate a cold- or warm-start configuration. The HP 3396 initiates a cold-start configuration when:

- the [CTRL] [DEL] keys are pressed simultaneously;
- a **RECONFIGURE** command is executed from system command mode;
- a power failure occurs for a length of time greater than the battery life or memory backup time of any INET instrument on the loop;
- INET instruments are added to the HP 3396 after it has been operating in a stand-alone condition only since cold-start.

The HP 3396 initiates a warm-start configuration, reverting back to its last active state, when :

- the loop is broken and reconnected in the same place;
- an HP-IB instrument is added or removed;
- an HP-IL instrument is added to the INET loop in such a way that no INET instrument addresses are changed;
- INET or HP-IL instruments are added to or removed from a working INET loop in a way that changes the address of one or more INET instruments;
- a RECONFIGURE statement is executed from a BASIC program;
- power failure occurs for a length of time shorter than the battery life or memory backup time of any one of the INET instruments;
- the power fails on the HP 19405B;
- a method or sequence file is loaded into the active workspace.

The last case does not occur as part of the HP-IL reconfiguration, as do the other cases. The “Configuring, Wait ...” message does not appear and INET addresses on the loop do not change. The HP 3396 reconciles the INET data path information in the INET Configuration Table with the current hardware and configuration, linking producers and consumers as required by the method or sequence. If the file contains set points for instruments that are not on the network, those set points will not be used, and an error message will be printed. However, the loop will generally still function for devices that do have a set point match; missing devices will be ignored.

The configuration process proceeds as follows:

1. The HP 3396 first determines if the configuration is a cold-start or warm-start. When the configuration is a cold-start, the HP 3396 instructs INET instruments to set their configuration parameters to the cold (power-up) status. Otherwise, under warm-start conditions, configuration parameters remain active and unchanged.
2. The HP 3396 uploads configuration parameters from the INET devices in loop-address order to determine the current state of the devices and data paths.
3. The HP 3396 then modifies the configuration parameters it has received based on whether the configuration is a cold- or warm-start and on the configuration constraints listed earlier in this chapter.
4. The HP 3396 then downloads the modified parameters back to the INET devices and checks to see that the modified parameters are accepted by each device on the loop.

Establishing and Changing INET Data Paths

INET protocol allows INET instruments to exchange a number of different types of data. Because each instrument on INET is actually a collection of functions housed together, INET addresses these functions separately as “objects”. Objects are instrument functions that act as producers or consumers of particular data types. Producers generate one data type and transmit it onto the loop for a corresponding consumer or consumers to use. The HP 3396, acting as an INET controller, routes data from producers to matching consumers. The data route from producer to consumer is defined as a “data path”. The HP 3396 controller keeps track of

- the model numbers of all producers and consumers,
- the types of data being exchanged,
- the number of data-producing sources, or channels, in use with each data path,
- the status of each data path.

All of this information is listed in the INET Configuration Table; see *Listing INET Devices* earlier in this chapter.

INET Data Types

Various types of data are transmitted between INET instruments. The data types are qualified by a format #, a digit from 0 to 9. Format numbers allow instruments to choose among formats for expressing the standard data types, preventing erroneous automatic configuration with instruments using different formats.

Common data types in use with the HP 3396 are listed in the table below.

INET Data Types

Data Type	Name	Description
A0	Run Annotation (Format 0)	Data records of printable ASCII strings with a maximum of 42 characters for annotating the plot during a run.
B0	B0 (Format 0)	Reserved.
C1	Chromatographic Signal (Format 1)	20 Hz signal points are represented by a 32-bit binary signed number. The HP 6890 has a 37-bit range. The 32-bit range that the HP 3396 accepts can be selected from any 32 contiguous bits out of the 37 produced by the HP 6890. See Using Methods in the HP 3396 <i>Operating Manual</i> for details on selecting the range. Since the HP 5890 FID dynamic range is 32-bits, it is completely covered
I0	Immediate Data (Format 0)	Sampler parameter data.
I1	Immediate Data (Format 1)	External events timetable data.
K0	Device Dependent Commands (Format 0)	Analytical instrument set point data or keyboard dialogs.
R0	Report Annotation (Format 0)	Printable ASCII data appended to reports. This may include bar code information, run logs, and external event notations.
S0	Sample Number (Format 0)	Three digit ASCII sample numbers ranging from 0 to 999 used in postrun report calculations.

INET Data-Type Configuration Constraints

Data Type Constraints	INET State(s) During Data Transmission
A0 Multiple active producers and active consumers allowed.	Run or Plot
B0 Reserved; status cannot be changed.	Not applicable
C1 Multiple active consumers, one active producer allowed.	All
I0 One active producer and one active consumer allowed. HP 3396 activates the I0 consumer in the instrument that is the active S0 producer.	All
I1 One active producer and one active consumer allowed.	All
K0 One active producer and multiple active consumers allowed.	All, except for Run
R0 Multiple active consumers and active producers allowed.	Postrun, Idle, and "Run may not begin"
S0 One active S0 producer, multiple active S0 consumers allowed.	Immediately after Postrun

In general during INET configurations, instruments with lower addresses have priority in getting their objects activated. This is not true, however, when the HP 19405A and another INET sampler (e.g., the HP 7673) coexist on the same INET loop. In this case the HP 7673 will take priority as the active sampler (S0 producer) irrespective of its address.

The configuration process generates an INET Configuration Table, which has at least one entry for each INET device on the network. For simple devices, that entry may contain only the address and model number of the device. For more complex instruments, the table has an entry for each object or separate data-consuming function within the instrument.

With the HP 3396 in system command mode, a user can get a listing of the INET Configuration Table. This command can be abbreviated by its first two characters

[I] [N] [ENTER]

The routing of INET data from producers to consumer is referred to as a *data path* in the table. Data paths are automatically configured at power-on, but may also be changed manually from the HP 3396 keyboard. A typical INET Configuration Table is illustrated below.

INET Configuration Table

* I N [ENTER]
LIST, EXIT, CHANGE, OR HELP [L/E*/C/H]: L [ENTER]

INET CONFIGURATION

<u>ENTRY</u>	<u>MODEL</u>	<u>ADDR</u>	<u>DATA PATH</u>	<u>STATUS</u>
1	3396C	0	C1 CONS CH 0	ACTIVE
2	6890A	8	C1 PROD CH 0	ACTIVE
3	6890A	8	C1 PROD CH 1	IDLE
4	3396C	0	K0 PROD CH 0	ACTIVE
5	6890A	8	K0 CONS CH 0	ACTIVE
6	3396C	0	R0 CONS CH 0	ACTIVE
7	6890A	8	R0 PROD CH 0	ACTIVE
8	6890A	8	R0 PROD CH 1	IDLE
9	6890A	8	R0 PROD CH 2	ACTIVE
10	3396C	0	S0 CONS CH 0	ACTIVE
11	6890A	8	S0 PROD CH 0	ACTIVE
12	6890A	8	S0 PROD CH 1	IDLE

LIST, EXIT, CHANGE, OR HELP [L/E*/C/H]: [ENTER]

Changing the INET Configuration Table

INET Configuration Table setpoints are stored in a method or sequence file when the **[STORE] [METH]** or **[STORE] [SEQ]** functions are executed. All HP 5890 and HP 6890 Gas Chromatograph data paths are stored in the method file. All HP 7673 Automatic Sampler data paths are stored in the sequence file. When an HP 6890 and HP 7673 are configured, the sampler data paths are also stored as part of the method. Other instruments on the network have their paths divided between the method and sequence files. When method and sequence files are loaded, the system automatically tries to implement the INET configuration implied by these files.

For typical INET systems comprising an HP 3396, an HP 7673, and an HP 6890, the automatic configuration will be acceptable in most cases. However, it is possible to make configuration changes manually using the **INET_CONFIGURATION** command. This command provides a way to alter the loop configuration through an interactive dialog at the HP 3396 keyboard. To enter this dialog, press

[I] [N] [ENTER]

After the INET configuration is listed (see previous page), the HP 3396 prompts

EXIT, CHANGE, OR HELP [E*/C/H] :

Press **[ENTER]** to exit the dialog and return to the system command mode. **[H] [ENTER]** will explain the abbreviations used in the INET Configuration Table and list some precautions to take when changing the status of an entry manually. Entering **[C] [ENTER]** allows one to alter the configuration of the loop manually. When **[C] [ENTER]** is pressed, the HP 3396 responds

CHANGE ENTRY NUMBER :

The only information listed in the INET Configuration Table that may be changed through this dialog is the status of a data path. Active producers and consumers can be deactivated, and inactive ones can be activated. The configuration of a particular data type is subject to the constraints listed earlier in this chapter.

If an INET data path is listed as IDLE and you wish to activate it, enter the number of the entry to be activated. To deactivate an entry number, enter its number with a [-] key before it. For example, to use the analog input for the HP 5890 instead of INET data, the C1 data path in the listing above must be deactivated. Entering [-][4] and [-][5] accomplishes this. When the INET configuration is listed again, this path is shown as IDLE. See the figure below.

When making Configuration Table changes, be sure that each data path has at least one active producer and one active consumer. The HP 3396 will deactivate data paths configured incorrectly, e.g., where there are too many or too few producers or consumers. Some INET instruments may also reject a configuration change themselves, e.g., if an option is not installed. After making changes, it is a good idea to list the INET Configuration Table again to verify them.

The table on the next page lists all the INET data types used in the HP 3396 and the INET instruments that produce and consume these data types.

INET Instruments as Data-Type Producers and Consumers

INET Instruments	Data Types								
	A0	B0**	C1	IO***	I1	K0	R0	S0	
HP 3396	C	C	C	P	P	P	C	C	
HP 6890	-	-	P	-	-	C	P	P	
HP 5890	-	-	P	-	-	C	-	-	
HP 7673*	-	P	-	C	-	C	-	P	
HP 19405A	P	-	-	C	C	-	-	P	
HP 19405B	P	-	-	-	C	-	-	-	
HP 1050L	-	-	-	-	-	-	P	P	
HP 1090L	-	-	-	-	-	-	P	P	

C = CONSUMER P = PRODUCER

* When in an INET configuration with the HP 5890 GC. When configured with the HP 6890 GC, the HP 7376 is not on INET. B0 data path is not in use.

** B0 data path is not in use.

*** IO data is coupled to SO data and is not listed separately in the INET Configuration Table.

Run and Report Annotation Data (A0 AND R0)

Run annotation is performed by the HP 3396 in response to its internal demands, such as retention time printing and to demands from Run annotation producers on the Instrument Network. The HP 3396 consumes Format 0 Run Annotation data which consists of printable ASCII characters sent by a producer during the Run or Plot states. The HP 19405B is a Format 0 Run Annotation Data Producer. This instrument sends the characters “EX” to the HP 3396 whenever any of their relays switch due to an External Events Timetable entry. Because multiple A0-producers are permitted, the HP 3396 may overprint simultaneous annotations.

Normally active, the A0-producer may be deactivated to prevent cluttering of the plot with annotations. For example, an annotation might overprint an important retention time, making it unreadable. To deactivate an A0-producer, first list the INET Configuration Table. Find the HP 3396 A0-consumer and deactivate it (the last consumer of a particular data type must be deactivated before the last producer may be deactivated). Then deactivate the A0 producer.

As an A0-producer, the HP 19405B IECM prints “EX” on the chromatogram each time an external event is executed. After the A0-producer is deactivated, the External Events Timetable entries will still be executed by the sampler during runs, but “EX” is no longer printed on the plot.

When all consumers on one data path are deactivated, the HP 3396 automatically deactivates the resulting unmatched producers, printing the message

UNMATCHED PRODUCERS DEACTIVATED

In the example above, the A0-producer is explicitly deleted. The HP 3396 finds no unmatched producers, and so no automatic deactivation is necessary. Either deactivation method is acceptable, but the former saves a few keystrokes in cases when all objects of a particular data path are to be deactivated. Of course, if you want to deactivate just some but not all of the producers on a data path, each must be deleted explicitly. If there are multiple active producers of a particular data type and format #, you need not deactivate the consumers before deactivating a producer. However, before deactivating the last active producer on a data path, you must deactivate all the consumers on that data path.

Report annotation is similar to run annotation in that, once the data path is activated, the printing occurs automatically. R0-producers, however, send their ASCII strings during the Postrun state to be printed on the HP 3396 and/or stored with the result file as part of the report for each run. R0-producers are polled in order of descending INET/HP-IL address, starting with the highest device address. An R0-producer may also request permission from the the HP 3396 to use its printer to print set points, for example, during the “Idle” and “Run may not begin” states. The HP 6890 is an R0 producer of run log information. A barcoder uses an R0 data path to produce sample information.

Producers and consumers of the report annotation data are activated and deactivated as described above for run annotation data consumers and producers.

B0 Data (B0)

When an HP 7673 is part of INET, the INET Configuration Table will list the sampler as a producer of B0 data and the HP 3396 as its consumer. However, this data path is not in use and cannot be activated from the HP 3396 keyboard.

Chromatographic Data (C1)

The HP 3396 is a consumer of Format 1 chromatographic data. Instruments such as the HP 6890 Gas Chromatograph, with INET compatibility, may send their digitized output signals to the HP 3396 using INET rather than the analog signal lines. The active C-producer continuously sends data to the active consumer, so one can list the signal level ([LIST] [ZERO] [ENTER]) or do an automatic threshold determination ([THRESH] [ENTER]) at any time. The HP 3396 can either plot the data ([PLOT]) or integrate the data and produce a report ([START]), just as with the analog voltage signal from the rear panel input. If it is an active C1 consumer, the HP 3396 plot of C1 data will automatically start when an HP 5890 GC column compensation run begins. The HP 6890 can perform compensation runs during the post-run state. The HP 3396 accepts the postrun state, and will not plot runs that occur during that time.

Only one Format 1 chromatographic data producer may be active at any time. When more than one HP GC is on the INET system, C1-producers can be deactivated as shown in *Changing the INET Configuration Table* above. Just deactivating the C1 consumer will shut off the Format 1 Chromatographic data producer. The HP 3396 will then use the signal applied to its analog voltage input as the signal to integrate. To activate a desired C1-producer, enter its entry number, and then reactivate the C1-consumer.

Immediate Data (I0 AND I1)

The immediate data formats supported by the HP 3396 are Format 0 for a portion of the [PREP] [SEQ] entries and Format 1 for [EXT()] key entries which may be entered directly via the SET EXT statements in BASIC, the external events timetable dialog, or through the [PREP] [METH] dialog.

When part of the INET loop (that is, when configured to an HP 5890 GC), the HP 7673 sampler or HP 19405A sampler controller uses the I0 data path to send prompts to the HP 3396 printer and to get response messages from the HP 3396 keyboard. When the HP 19405A or HP 19405B are used as external event controllers, they use the I1 data path to send prompts and get responses in the same way. In any network with only an INET sampler, and either an HP 19405A or an HP 19405B, it will be automatically configured at power-on as a consumer of one or both formats of Immediate data. The HP 3396 configures itself as the producer of the two data formats, thus establishing control over the sampler or sampler controller.

Note that the sample data type (S0, described below) and the immediate data format, I0, are coupled in the HP 3396. The I0 data path is automatically activated when the S0 data type is activated, but the I0 data path is not listed separately in the INET Configuration Table. Immediate data formats may be transmitted during any INET state.

To depart from the power-on network configuration for I1 data, use the [I][N] [ENTER] key sequence. The constraints for immediate data are given in the table above. Even in a single sampler system there may be reasons to deactivate the I1 data path. For example, deactivating the path prevents casual users from inadvertently changing the External Event Timetable, perhaps causing an undesired external event. The HP 19405B IECM can control eight external events. If you need more than eight external events, another HP 19405B can be added to the system. In this case the [I][N] dialog selects which HP 19405B is online to the EXT() commands via the I1 path.

Device Dependent Commands (K0)

The HP 6890, the HP 5890, and the HP 7673 (when part of the INET loop) are consumers of K0 commands. The K0 data path allows the HP 3396 as a K0 producer to send command strings changing the set points of these instruments, or cause certain other actions to be taken, as long as a run is not in progress. Fundamentally, a single K0 transaction consists of the HP 3396 sending a message to an INET device and the INET device sending a response back to the HP 3396. To enter these commands from the HP 3396 keyboard, Option 6, the [PREP] [METH] dialog, or the INET_I0 command in BASIC, may be used. Entering commands is explained in the section called *Controlling INET Instruments Through BASIC* earlier in this chapter.

The K0 data path producer (the HP 3396) and all consumers are automatically configured as ACTIVE when power is switched on. Although K0 consumers can be deactivated, there is no reason to deactivate them since the indicated device address determines which instrument is the active consumer of a particular command string.

Sample Data (S0)

At power-on configuration, the HP 3396 is configured as an active S0-consumer and the INET sampler is the active producer of sample data. S0 data describes the sample most recently analyzed and may represent bottle numbers or an ID code. Typically the S0 data is the bottle number of the most recently injected vial. Since I0 data is coupled to S0 data, the HP 3396 is configured as an active I0-producer and the INET sampler is the active consumer of I0-data at power-on.

As an S0 consumer, the HP 3396 uses the sample number (bottle number) as an index into the sample table for calibrated reports (ESTD, ISTD, and NORM). The HP 3396 also prints the sample number in the upper right hand corner of the report. If the Sample Number cable is used as the source of this information, the HP 3396 S0 consumer object should be IDLE.

To deactivate the active S0-producer, you must first deactivate all active S0-consumers (typically only the HP 3396). When the S0-consumers are deactivated, the HP 3396 automatically deactivates the matching S0-producers. At this point, no sample data will be transmitted to the HP 3396.

To switch from one active producer to another (if several of one type are connected to INET), enter “C” for the change dialog after listing the INET Configuration Table. Deactivate all the matching consumers, then deactivate the current producer and activate the desired one. Finally, reactivate the desired consumer(s). See the configuration constraints listed above.

HP 3396 Background Tasks

As the INET controller, the HP 3396 manages the interactions of analytical equipment as described in the preceding subsections. In addition to the operation and data structures described, INET performs several functions that are apparent only by their indirect effects on the instruments.

Among these functions are readiness, status polling, and error detection. The HP 3396 continuously polls each of the following:

- HP-IL addresses (INET only) in address order for readiness and status.
- HP 3396 keyboard.

After each status poll cycle the INET controller conducts an INET “readiness to begin a run” poll if in the Idle or Postrun state. In addition, pressing **[R] [E] [A] [ENTER]** causes an immediate poll of INET devices, including the most recent host computer readiness return, and prints the results on the printer/plotter.

The network state determines the response to **[START]** key presses from INET instruments and the host computer. The status indicators (LEDs) on the HP 3396 keyboard are set to reflect the state of the network (READY, RUN, KEYBD) and the host computer (COMM), if one is connected. Unless a sequence of runs is being started, any start message or keystroke starts a run immediately, with the HP 3396 printing

```
START; not ready
```

if it is not ready to start a run. If a sequence of runs is being started from a program or if the **[SEQ] [START]** keys were pressed, the network will wait for all instruments to become ready before starting any run. The HP 3396 will print the message

Waiting for System Readiness

and hold off the actual start of the run.

During the Prerun, Run, and “Run may not begin” INET states, the ready polling is suspended. If the Instrument Network is in any of these states, it has already accepted a start signal or intentionally ignored a start signal, so by definition, it is not ready. No polling is necessary until the network proceeds to the Postrun state.

The HP-IL status polling also allows instruments on INET to print warning and error messages on the HP 3396 printer/plotter.

Creating the Little Falls Look
Using this document as an Interleaf template

Compatible Disk Drives 11-2
Using Disk Drives 11-7
Understanding HP-IL and HP-IB 11-12

Using Disk Drives

Using Disk Drives

Compatible Disk Drives

You can elect to save HP 3396 files, data, and BASIC programs externally on disk drives or in a host computer system. You can also save them on the data storage extension cards of an HP 3396 Series III. For more information about extension cards, see *Saving Integrator Data* in the HP 3396 *Operating Manual*.

The HP 9153 Disk Drive contains a hard or fixed disk. The other drives listed use flexible, or “floppy”, disks.

Disk Drives Compatible with the HP 3396

Disk Drive Model Number	Notes
HP 9114A or B	HP-IL, battery-operated, floppy drive
HP 9122C or D	HP-IB device ²
HP 9153A or C ¹	10 Megabyte Winchester, HP-IB device ²

Note: The HP 3396 is only compatible with double-sided *subset 80* command set disk drives.

¹When used with the HP 3396 Series II, the HP 9153C 10 megabyte disk drive should be divided into the maximum number of volumes. This will keep disk directory listings on the HP 3396 to a reasonable length. See the HP 9153C *Getting Started* manual for instruction on setting the configuration switch to determine the number and size of volumes.

²Requires use of an HP 82169A HP-IL/HP-IB Interface.

Hewlett-Packard's Peak-96 Information Manager allows easy storage of integrator files at a host computer.

Listing Devices on the Loop

Compatible disk drives use the Hewlett-Packard Interface Loop or Hewlett-Packard Interface Bus.

1. **Press [S] [Y] [ENTER] to list all the devices currently active on the loop.**

This is a typical listing for the system with an HP 9122 HP-IB disk drive and two SRAM extension cards.

ADDRESS	DEVICE ID	ACCESSORY ID & CLASS
8	HP82169A	43H INTERFACE
1-7	RESERVED FOR HPIB DEVICES	
SLOT1		2MB-SRAM
SLOT2		512KB-FLASH

DISC NAME	ADDRESS	DRIVE#	VOLUME ID	MEDIA
A	7		EPA1	
B	7		WATER	
C	SLOT1		CLWAT	SRAM
D	SLOT1		METHOD	SRAM
F	SLOT1		AUG	SRAM
G	SLOT1		SAVE	SRAM
I	SLOT2		TEMP	SRAM
J	SLOT2		TEMP2	SRAM

RS-232-C SWITCH SETTINGS

Baud 4800
Timeout 15 sec
Handshake Delay Disabled
Hardware Handshake Enabled

Example

2. **Press [R] [E] [A] [ENTER] to check system readiness.**

Autoconfiguration and Reconfiguration

After the cables are connected and all instruments are switched on, the HP 3396, as controller, configures the loop. Configuring includes

- recognizing the types and internal functions of the devices in the network,
- assigning addresses.

When assigning addresses, the HP 3396 always assigns address 0 to itself. Addresses 1 to 7 are reserved for HP-IB devices and are set by switches on the HP-IB devices themselves. Addresses 8 to 31 are assigned in order around the loop starting with the device connected to the controller's HP-IL output receptacle. Data or commands destined for a device on the loop often include the address of that instrument. When the order of instruments in the loop is changed, the system must be reconfigured so that the HP 3396 is aware of the new address for each device. The HP 3396 cannot detect the removal of an HP-IB device unless the system is reconfigured by

- breaking the loop,
- resetting the HP-IB interface (by pressing the reset button),
- executing a RECONFIGURE command in BASIC or system command mode.

At the direction of the controller, the loop automatically reconfigures under the following circumstances:

- recovery from a power failure,
- recovery from a break in the loop (e.g., breaking the loop to add a device, or a power failure at a remote device),
- executing a RECONFIGURE command from BASIC or system command mode.

1. **Press [R] [E] [C] [ENTER] to reconfigure the system when instruments are added or moved on the loop.**

If there are more than 31 devices on the loop, the HP 3396 prints TOO MANY HP-IL OR HP-IB DEVICES.

When the loop is broken, the HP 3396 prints

```
LOOP DOWN: TIMEOUT
```

When the loop is restored, the HP 3396 will configure again as described above.

Once the configuration is done, the **SYSTEM** command may be used to list the addresses of the devices on the loop. For example, it is necessary to know a printer's address when using option 5 (postrun report option) or when sending a listing of a Method file to an external printer via the **XADDRESS** command. **[S] [Y] [ENTER]** will list HP-IL and INET devices on the loop and their addresses. The current settings for the RS-232-C switches are also printed below the device listings. HP-IB printers are not identified in this table.

On HP-IL, after devices have transmitted data to the HP 3396 as the system controller, the integrator sends the data it received back around the loop. When there is a discrepancy between data sent out by the transmitting device and the data sent back by the HP 3396, the device will send the controller an End of Transmission Error message. When this message is received, the integrator prints

"ETE" ERROR

This error could be due to faulty electronics in one or more devices on the HP-IL loop or heavy electrical/radio interference preventing data from successfully traveling the HP-IL loop.

Using Disk Drives

See the HP 3396 *Reference Manual* for instruction about how to install disk drives with the HP 3396.

Accessing Disk Drives

Commands and key sequences that access disk drives are listed below. All commands listed below are discussed in the HP 3396 *Operating Manual* unless otherwise indicated.

Listing files on disk:	Operating Manual chapter...
[LIST] [CALIB] <i>filespec</i> [ENTER]	6
[LIST] [METH] <i>filespec</i> [ENTER]	8
[LIST] [SEQ] <i>filespec</i> [ENTER]	9

Listing files on disk to an external printer: this chapter

Note: The XADDRESS (external address) must be set to successfully list files to an external printer.

[CTRL][LIST] [CALIB] *filespec* [ENTER]
[CTRL][LIST] [METH] *filespec* [ENTER]
[CTRL][LIST] [SEQ] *filespec* [ENTER]

Storing files on disk:	Operating Manual chapter...
[STORE] [CALIB] <i>filespec</i> [ENTER]	6
[STORE] [METH] <i>filespec</i> [ENTER]	8
[STORE] [SEQ] <i>filespec</i> [ENTER]	9

Creating the Little Falls Look
Using this document as an Interleaf template

Loading files from disk:

[LOAD] [CALIB] <i>filespec</i> [ENTER]	6
[LOAD] [METH] <i>filespec</i> [ENTER]	8
[LOAD] [SEQ] <i>filespec</i> [ENTER]	9

Deleting files from disk:

[DEL] [CALIB] <i>filespec</i> [ENTER]	6
[DEL] [METH] <i>filespec</i> [ENTER]	8
[DEL] [SEQ] <i>filespec</i> [ENTER]	9

System commands: this chapter

READY
RECONFIGURE
SYSTEM

File and disk commands: Operating Manual
chapter...

COPY <i>filespec, filespec</i>	7
CREATE <i>filespec, size</i>	BASIC User's Manual
DIRECTORY <i>diskspec</i> or <i>filespec</i>	7
FORMAT <i>diskspec, volume, max files</i>	7
PACK <i>diskspec</i>	7
PURGE <i>filespec</i>	7
Option 2: Storing data from runs	7
Option 5: Listing post-run data	10

Refer to the HP 3396 *BASIC Language User's Manual* for information about file storage and retrieval from BASIC.

File System Commands

The table below lists the commands that control disk drives. More detailed descriptions of the system commands may be found in the HP 3396 *Operating Manual*. BASIC commands and statements are described in more detail in the *BASIC Language User's* and *BASIC Language Reference* Manuals. For more information on using extension cards with the HP 3396 Series III, see *Saving Integrator Data* in the HP 3396 *Operating Manual*.

File System Commands (M:disk or external disk drives)

System Command	Abbr	Syntax	Valid File Extensions
ANALYZE,I	--	ANALYZE <i>filespec</i> , <i>l</i>	.RAW, .BNC, .BNA
ASSIGN	AS	ASSIGN <i>keynumber</i> , <i>filespec</i>	.BAS
COPY	CO	COPY <i>filespec1</i> , <i>filespec2</i>	all
CREATE	CR	CREATE <i>filespec</i> , <i>size</i>	all
[CTRL] [LIST]		[CTRL] [LIST] [CALIB] <i>filespec</i>	.CAL, .MET, .SEQ
	^ [LIST]	[METH] [SEQ]	
[DELETE]	--	[DEL] [CALIB] <i>filespec</i>	.CAL, .MET, .SEQ
		[METH] [SEQ]	
DIRECTORY	DI	DIRECTORY <i>diskspec</i> or <i>filespec</i>	all
FORMAT	--	FORMAT <i>diskspec</i> , <i>volume</i> , <i>numberfiles</i>	n/a
[LIST]	--	[LIST] [CALIB] <i>filespec</i>	CAL, .MET, .SEQ
		[METH] [SEQ]	
[LOAD]	--	[LOAD] [CALIB] <i>filespec</i>	.CAL, .MET, .SEQ
		[METH] [SEQ]	
PACK	PA	PACK <i>diskspec</i>	n/a
PURGE	PU	PURGE <i>filespec</i>	all
READY	REA	READY	n/a
RECONFIGURE	REC	RECONFIGURE	n/a
RENAME	REN	RENAME <i>filespec1</i> , <i>filespec2</i>	all
[STORE]	--	[STORE] [CALIB] <i>filespec</i>	.CAL, .MET, .SEQ
		[METH] [SEQ]	
SYSTEM	SY	SYSTEM	n/a

n/a = not applicable

continued on next page

File System Commands (cont'd)

BASIC				
Command or Statement	Abbr	Syntax		Valid File Extensions
ASK # DATUM	--	ASK # channel:DATUM string variable		all
ASK # LENGTH	--	ASK # channel:LENGTH numeric variable		all
ASK # LIFTYPE	--	ASK # channel:LIFTYPE numeric variable		all
ASK # RECORD	--	ASK # channel:RECORD numeric variable		all
COPY	CO	COPY filespec1,filespec2		all
CREATE	CR	CREATE filespec, filesize		all
DEVICE\$	--	DEVICE\$ (HP-IL device address)		n/a
DIRECTORY	DI	DIRECTORY diskspec or filespec		n/a
FORMAT	--	FORMAT diskspec, volume, numberfiles		n/a
GET	G	GET filespec		.BAA or .BAS
GETCALIB	--	GETCALIB "filespec"		.CAL
GETMETH	--	GETMETH "filespec"		.MET
GETSEQ	--	GETSEQ "filespec"		.SEQ
JOIN	JO	JOIN filespec		.BAA
LOAD	LO	LOAD filespec		.BAA
PACK	PA	PACK diskspec		n/a
PURGE	PU	PURGE filespec		all
READ #	--	READ # channel:variable list		all
RELEASE REST	--	RELEASE REST # channel		n/a
RENAME	REN	RENAME filespec1,filespec2		all
RUN	R	RUN filespec		.BAA and .BAS
SAVE	SA	SAVE filespec		.BAA and .BAS
SET # MARGIN	--	SET # channel:MARGIN column number		all
SET # RECORD	--	SET # channel:RECORD numeric expression		all
SSET VOL	--	SSET VOL SLOT#, #volumes		n/a
SYSTEM	SY	SYSTEM		n/a

¹BASIC is installed with Option 100.
n/a = not applicable

Understanding HP-IL and HP-IB

The HP 3396 is compatible with various types of Hewlett-Packard Interface Loop, Hewlett-Packard Interface Bus, and Instrument Network devices.

HP-IL is a serial two-wire connection and a software protocol that allows printers, storage devices, and analytical instruments to communicate with each other. All INET devices are HP-IL-compatible.

HP-IB is a parallel bus link with its own protocol, equivalent to IEEE-488.

HP-IL supports up to 31 devices on the “loop”, reserving seven of these for HP-IB devices such as printers and disk drives. HP-IB is an entirely different type of instrument interface that connects devices in parallel and uses a different message protocol. HP-IB devices are integrated into the HP-IL through the HP 82169A HP-IL/HP-IB Interface.

More in-depth information about HP-IL may be found in the book *The HP-IL System: An Introductory Guide to the Hewlett-Packard Interface Loop* written by Kane, Harper, and Ushijima and published by OSBORNE/McGraw Hill.

How HP-IL Operates

HP-IL devices play one of three different roles: *controller*, *talker*, or *listener*. Each loop has one device that acts as a controller and devices that talk and listen. As the HP-IL controller, the HP 3396

- assigns addresses and talking and listening roles to each device,
- services device requests, and
- initiates the transfer of data from talkers to listeners.

The HP 3396 is capable of initiating actions at a remote device on the loop.

On the loop talkers are message senders and listeners are message receivers. Some devices, such as disk drives, function as both talkers and listeners, while printers are primarily listeners.

An illustration of a loop with HP-IL and an HP-IB device is shown below.

HP-IL System

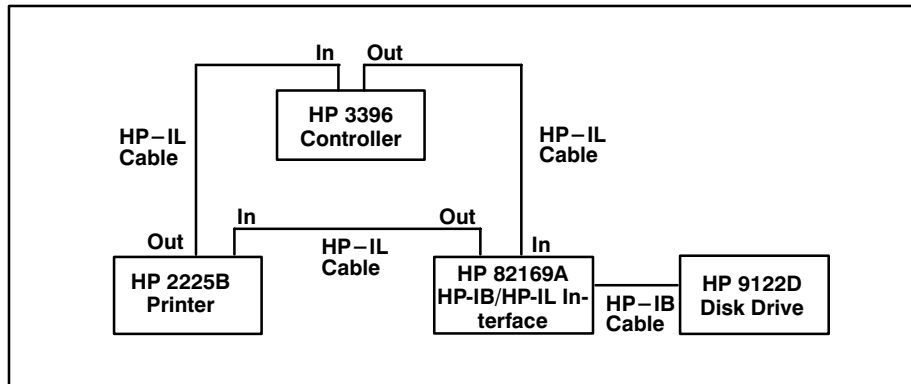

Creating the Little Falls Look
Using this document as an Interleaf template

What is the RS-232-C Interface?	12-2
Installing RS-232-C Devices	12-3
Choosing the Proper Cable	12-4
Connecting the Cable	12-8
The RS-232 Configuration Settings	12-9
Changing the RS-232 settings with the SSET RS232 command	12-10
Matching RS-232-C Protocol	12-15
Using External BASIC	12-17
Using RS-232-C in Remote Mode	12-18

Using RS-232-C Devices

Using RS-232-C Devices

What is the RS-232-C Interface?

The RS-232-C link is a single-cable, bidirectional interface that conforms to Electronic Industries Association (EIA) standards. The HP 3396 can be connected via RS-232-C link to a computer and other external devices to send and receive data and commands.

An external terminal may be connected to the HP 3396 via RS-232-C for the purpose of writing and executing BASIC programs. Instructions on how to use the external BASIC capability are included in this chapter.

Communications between an HP 3396 and an external computing device require programs to be running on the host computer to operate the RS-232-C link. HP Peak-96 is the Hewlett-Packard product that allows an IBM-compatible personal computer to control the HP 3396. This chapter does not provide detailed operating and programming instructions for the range of other possible host computers. This information is contained in the *RS-232-C Programmer's Guide* (03396–90335).

Installing RS-232-C Devices

The RS-232-C hardware includes the “RS-232” connector on the rear panel, the configuration switches under the keyboard, and the choice of the DTE (male) cable, or the DCE (female) cable. The HP 3396 can be configured to be Data Terminal Equipment (DTE), the terminal end of the RS-232-C interface, or Data Communication Equipment (DCE), the modem end of the interface, whichever is appropriate. The cable determines the mode of operation.

Caution

The HP 3396 cannot function as a general purpose terminal.

RS-232-C Interface installation involves

2. Choosing the proper cable.
3. Connecting the cable.
4. Setting RS 232 parameters using the SET_SYS dialog.
5. Matching RS-232-C protocol.

Choosing the Proper Cable

The physical connection for the RS-232-C link is made by a cable with a 15-pin male connector to the RS-232 receptacle on the rear panel of the HP 3396. Since the HP 3396 can be configured as either Data Terminal Equipment (DTE) or Data Communications Equipment (DCE), two different cables may be used.

RS-232-C Cables

Cable Option # (Part Number)	Description	HP 3396 Mode
301 (03396-60520)	15-pin connector to 25-pin female "D" RS-232-C connector	DCE
302 (03396-60510)	15-pin connector to 25-pin male "D" RS-232-C connector	DTE
303 (03396-60530)	15-pin connector to 9-pin female "D" RS-232-C connector	DCE
304 (03396-60520) (HP 92224M)	15-pin connector to 25-pin female "D" RS-232-C male-to-male converter	DCE

The most straightforward way to connect two devices is to determine which device transmits its data on which connector pin. Then make sure the other device receives data on that pin. (In most cases only pins 2, 3, and 7 are used.)

The HP 3396 implements the RS-232-C functions shown below.

RS-232-C Functions Implemented on the HP 3396

Connector			Mnemonic	Description	Direction
25-pin (DTE)	25-Pin (DCE)	9-Pin (DCE)			
1	1	–	AA	Protective Ground (Shield)	--
2	3	2	BA	Transmitted Data	DTE → DCE
3	2	3	BB	Received Data	DCE → DTE
4	4	7	CA	Request to Send	DTE → DCE
5	5	8	CB	Clear to Send	DCE → DTE
–	6	6	CC	Data Set Ready	DCE → DTE
7	7	5	AB	Signal Common	→ --
–	8	1	CF	Received Line Signal Detector	DCE → DTE
–	20	4	CD	Data Terminal Ready	DTE → DCE →

Caution

Voltages applied to any RS-232-C connection must not exceed 25V peak with respect to signal common, or damage to the HP 3396 may result.

DTE or DCE?

The needs of the RS-232-C device being connected to the HP 3396 determine which cable and configuration are used. When a DCE device, such as a modem, is being connected, the HP 3396 is configured as DTE and uses the DTE cable. When the DCE cable is used, the HP 3396 looks like a modem to DTE devices.

The HP 3396 DTE cable has a male 25-pin “D” connector. When the HP 3396 has the DTE cable connected, it behaves as a DTE device. The

connected device must be a DCE device, transmitting on pin 3 (BA) and receiving on pin 2 (BB).

There are two DCE cables for the HP 3396. One (03396–60520) has a female 25-pin “D” connector. Use this cable to connect the HP 3396 to a DTE device, transmitting data on pin 2 (BB) and receiving on pin 3 (BA). The other DCE cable (03396–60530) has a female 9-pin “D” connector. Use this cable to connect the HP 3396 to a DTE device, transmitting data on pin 3 (BA) and receiving on pin 2 (BB).

By RS-232-C convention, all DCE devices should have a FEMALE 25-pin “D” connector associated with them, and all DTE devices should have a MALE 25-pin “D” connector associated with them. However, many manufacturers use custom connectors or, to avoid male bulkhead fittings, use female connectors on their DTE devices and provide a male-to-male cable. Therefore, just looking at the connector on the RS-232-C device is not a reliable way to determine which cable you should use. In addition not all RS-232-C devices clearly show whether they are DTE or DCE. Some may be switchable as well (such as the HP 3396).

Consult the reference material provided with your RS-232-C device to be sure that the HP 3396 cable you received is the appropriate one. The signals shown in the table on the previous page should match so that an output from the HP 3396 is connected to the appropriate input on the RS-232-C device and vice versa. The connectors should be of opposite gender. The HP 3396 and the RS-232-C device should operate properly if these two conditions are met.

If these conditions are not met and the output and input signals do not match or the connectors are not opposite in gender, customized cables, or adapters are required.

Customizing Cables

You may find that the signals with the same mnemonics in both instruments are matched input to output, but the connector gender is the same in both instruments (both male or both female); then you need a gender-changing adapter. Gender-changing adapters are either male-to-male or female-to-female adapters with the pins connected straight through (#1 to #1, etc.).

On the other hand, you may find that the signals with the same mnemonic in both devices are the same, i.e., both inputs or both outputs. You will need an adapter to cross-connect the devices. Such adapters for DTE devices (both devices transmitting data on Pin 2, both with male connectors) are called modem-eliminator or null-modem adapters. They cross-connect the commonly used DTE signals so that the needs of two DTE devices may be satisfied.

With the following set of adapters, you should be able to conquer almost any RS-232-C situation:

- male-to-male straight through (HP 92224M), to change gender,
- female-to-female straight through (HP 92224F), also to change gender,
- modem-eliminator or null-modem, usually female-to-female, to allow two DTE devices to be connected together.

It is also possible that you may need a combination of cross-connecting and gender-changing adapters. Similar adapters can be constructed or purchased for other combinations of connectors and device types.

Connecting the Cable

Caution

Connecting the HP 3396 RS-232-C cable to incompatible instruments may damage either the HP 3396, the external device, or both. Be sure that your computer or peripheral conforms to EIA Standard RS-232-C.

After you have determined that your external device meets EIA Standards for RS-232-C, follow the steps below to connect your cable.

1. **Choose the appropriate DCE or DTE RS-232-C interface cable.**
2. **Plug the DTE or DCE cable into the connector labeled “RS-232” on the rear panel of the HP 3396.**
3. **Plug the opposite end of the cable which has a 9- or 25-pin “D” connector into the RS-232-C input jack on the external device.**

The RS-232 Configuration Settings

The RS-232 default configuration switch settings are set at the factory. The eight switches are located under the keyboard of the HP 3396. The configuration parameters are:

- data rate (from 150 to 19,200 baud),
- hardware handshaking CA/CB (Request to Send, Clear to Send), and
- duration of handshake timeouts (short—15 seconds, or long—3 minutes).

The default settings can be changed by removing the keyboard and physically changing the settings. The instructions for changing the switch settings are on the next page. The operating parameters can be changed with the **SSET RS232** dialog without opening the cabinet (see below), and will remain in effect until a cold start occurs.

CONFIGURATION

UP

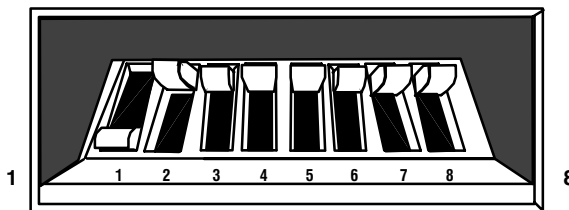

DOWN

Switch	RS-232-C Switch Settings		Function	Data Rate Table		
	UP	DOWN		Rates (BAUD)	Switch 1	Switch 2
1.	_____		Data Rate (see table)			
2.	_____		Data Rate (see table)	19200	UP	UP
3.	_____		Data Rate (see table)	9600	DOWN	UP
4.	Disable	Enable (CA/CB)	Hardware Handshake	4800	UP	DOWN
				2400	DOWN	DOWN
5.	Off	30 msec	Handshake Delay	1200	UP	UP
6.	15 sec	3 m in	Timeout	600	DOWN	UP
7.			Not Used	300	UP	DOWN
8.			Not Used	150	DOWN	DOWN

Changing the RS-232 settings with the SSET RS232 command

The RS-232 Configuration Switches

The RS-232 default configuration switch settings are set at the factory. The eight switches are located under the keyboard of the HP 3396. The configuration parameters are:

- data rate (from 150 to 19,2000 baud),
- hardware handshaking CA/CB (Request to Send, Clear to Send),
- duration of handshake time-outs (short—15 seconds, or long—3 minutes).

The default settings can be changed by removing the keyboard and physically changing the settings. The operating parameters can be changed with the SSET RS232 dialog without opening the cabinet (see below), and will remain in effect until a cold start occurs.

Changing the Default RS-232 Configuration Switches

1. Turn off and unplug the HP 3396.
2. Remove the keyboard by prying it off from the bottom. Be gentle with the keyboard. You can move it aside to locate the switches without unplugging the keyboard cable.
3. Locate the RS-232 switches. They are in a red panel at the lower right hand corner.
4. Set the switches to the desired configuration.
5. Replace the keyboard.

6. Plug in and turn on the integrator.
7. Check to be sure you have the settings you want by typing [S][Y][ENTER].

Changing the RS232 settings with the SSET RS232 command

The SSET RS232 keyboard dialog over-rides the RS-232 switch settings.

To change the settings in the SSET RS232 dialog, type SSET RS232 in system command mode. (You are in system command mode whenever the * prompt is present.) An example dialog is shown below.

* SSET RS232 [ENTER]

RS 232 PARAMETERS

BAUD [150/300/600/1200/2400/4800/9600*/19200]: **19200** [ENTER]

1. Press ENTER to retain the current setting of 9600; type in the numerals for any other setting and then press ENTER.

TIMEOUT...Long (180 sec), Short (15 sec) [L/S*]: **L** [ENTER]

2. Press ENTER to retain the current Short setting; type L and press ENTER to change the setting to Long.

HANDSHAKE DELAY. Enabled (30mS), OFF [E/O*]: **[ENTER]**

3. Press ENTER to retain the current setting of OFF; type E and press ENTER to change the setting to Enabled.

HARDWARE HANDSHAKE. Enabled, Disabled [E*/D]: **D** [ENTER]

4. Press ENTER to retain the current setting of Enabled; type D and press ENTER to change the setting to Disabled.

Remember that the settings will return to the default settings whenever a cold start occurs unless you change the physical settings of the switches (see instructions, above). BASIC can be used to change the parameters using PEEK and POKE. See the HP 3396 *BASIC Language Manual* for more information.

Listing the Switch Settings

You may list the current setting of the RS-232-C configuration switches by pressing

[S] [Y] [ENTER]

After printing the status of the INET loop, the HP 3396 will print the current values of these switches. Shown below is the HP 3396 listing of factory-set values for the RS-232-C switches.

```

RS-232-C           SWITCH SETTINGS
Baud               9600
Timeout           15 sec
Handshake Delay   Off
Hardware Handshake Disabled

```

Use the descriptions below and the manual for your RS-232-C device to decide if any configuration settings need to be changed.

Data Rate Switches 1, 2, 3

The data rate is the number of bits per second (or baud) transmitted by the link. Switches 1 to 3 allow you to select the rate your equipment can handle. For RS-232-C, the available rates are 150, 300, 600, 1200, 2400, 4800, 9600, and 19200 baud. The HP 3396 rate must be set equal to the rate that the external device is using. For applications in which only reports, processed peak data, setpoints, methods, sequences, and calibrations are to be transmitted, any transmission rate from 150 to 19200 baud is acceptable.

If you plan to transmit raw (unbunched) data directly from the HP 3396 to the external device, you must select a rate greater than or equal to 2400 baud.

Hardware Handshake Switch 4

Switch 4 enables or disables the hardware handshake—Request to Send/Clear to Send (CA/CB) for DTE operation of the HP 3396. Handshaking is a timing feature provided to allow external devices to hold off HP 3396 transmissions in conversation mode with signals on the CB line. Handshaking does not apply to BX (external BASIC) mode, DCE mode, or to I/O commands initiated from a BASIC program via the READ # and PRINT # statements.

If hardware handshaking is enabled, the HP 3396 turns CA ON before each buffer of data is to be transmitted. It then checks CB. If CB is ON, the HP 3396 transmits the data; otherwise it waits for the external device to turn CB ON before transmitting the data. The HP 3396 will wait only until the end of the timeout period, which is determined by switch 10, for the external device to turn CB ON. If the external device does not turn CB ON, the HP 3396 will timeout and revert to default protocol. However, the HP 3396 cannot itself disable hardware handshaking, so if the remote device continues to be unresponsive, the HP 3396 will timeout repeatedly. If the external device responds to the hardware handshake before the end of the timeout period, the HP 3396 turns off CA at the end of a data transmission and the process starts again.

If you wish to use this feature, you **MUST** use the DTE cable regardless of the device type of the external instrument. You may have to make an adapter to use the DTE cable and connect the correct RS-232-C signals together. (See *Customizing Cables* above.) Whenever the DTE cable is used, either the external device must implement the CA/CB handshake or you must disable the handshake or, again, the HP 3396 will timeout repeatedly when host communication is attempted.

Handshake Delay Switch 5

Switch 5 may be set to force the HP 3396 to wait 30 milliseconds after receiving each handshake response before actually transmitting. This provides for host computers which may acknowledge a handshake quickly but are not immediately ready to receive. This delay applies to all handshakes.

Timeout Duration Switch 6

Switch 6 may be set for short (15-second) or long (3-minute) timeouts, depending upon the response time of the computer to be connected. The HP 3396 aborts unfinished communications and returns to the default protocol if it receives no handshake response from the computer before the timeout period ends. One or more of the handshake options— hardware RS-232-C CA/CB (Request to Send/Clear to Send), Remote (ENQ/ACK), or Read Sequence—must be active for the timeout to be in effect.

The timeout only applies if a handshake response is expected in conversation mode and does not arrive within the timeout window. The HP 3396 will wait indefinitely for the host computer to send messages if the pause occurs when no handshake response is expected. Timeouts do not apply to BX (External BASIC) mode or to I/O commands initiated from a BASIC program via the READ # and PRINT # statements.

Switches 7 and 8 are not used

Matching RS-232-C Protocol

For RS-232-C communications to be completed successfully, the protocol for the remote device must match the HP 3396 protocol. Protocol is the set of conventions that determines the format and relative timing of the message exchange between the remote device and the HP 3396. When using the DTE cable, set up your remote RS-232-C device to match the HP 3396 default protocol. The default protocol is listed below:

Default RS-232-C Protocol

Default Parameter	Setting	Meaning
Parity	OFF	The parity bit in the character frame is set to zero for transmitted characters, and is not checked for received characters.
Echo	OFF	Characters received by the HP 3396 are not returned (echoed) back to the sender.
Local Handshake	ON	When the HP 3396 receives an Enquire (E_0) character, it transmits an Acknowledge (A_K) character.
Remote Handshake	OFF	The HP 3396 sends no Enquire and expects no Acknowledge character. Data are sent with no handshake, one line at a time.
Maximum Buffer Size	80	The maximum number of characters the HP 3396 can send or receive in a single transmission, excluding the conversation and stage mnemonics, checksum, handshake characters, and termination sequence.
Remote Device Capabilities	MUTE	The HP 3396 does not expect the remote device to respond to messages. The remote device may send configuration commands if it is able.
Local Termination Sequence		Messages from the HP 3396 will be terminated by a Carriage Return character followed by a Line Feed character. ($\text{C}_R \text{L}_F$)
Remote Termination Sequence		The HP 3396 expects messages from the host to be terminated by a Carriage Return character followed by a Line Feed character. ($\text{C}_R \text{L}_F$)
Read Sequence	NONE	The HP 3396 does not wait for a special character sequence during a read operation before transmitting.
Checksum	NONE	The HP 3396 will not include a checksum between the text and the termination sequence.

Using External BASIC

External BASIC allows the BASIC capabilities of the HP 3396 to be accessed from a remote terminal via RS-232-C.

To use external BASIC:

1. **Choose the appropriate DCE cable and connect your terminal to the HP 3396 using the instructions earlier in this chapter.**
2. **Type “BX” on the HP 3396 keyboard.**
3. **Enter programs from the remote terminal.**

These programs may be listed on the HP 3396 printer via the XLIST command while the XADDRESS is set to -2.

4. **Enter “EX” from remote terminal to return to HP 3396 keyboard entry.**

In “BX” mode any characters normally printed on the HP 3396 will be directed to the terminal display.

For more information about external BASIC see the HP 3396 *BASIC Language User’s Manual*.

Using RS-232-C in Remote Mode

In REMOTE mode control of communications and of the HP 3396 have been acquired by a host computer. While in REMOTE mode, the prompt changes to a # and the computer has access to all key sequences available to the user in LOCAL mode.

Operation in REMOTE mode gives the host potentially full control of the HP 3396. A host device may acquire control of the HP 3396 any time except when the HP 3396 is

- executing a command
- in the midst of a run
- printing
- in BASIC or external BASIC.

Once the HP 3396 is in REMOTE mode, the HP 3396 keyboard is locked except for the **[START]**, **[STOP]**, **[SEQ]**, **[CTRL]**, and **[BREAK]** keys. The amber COMM indicator will turn on and stay on to let you know the communication link is established.

The operation and programming requirements of remote RS-232-C devices vary. Because of the range of possible host computers, it is beyond the scope of this networking guide to give detailed operating or programming instructions for REMOTE mode. See the *HP 3396 RS-232-C Programmer's Guide* (03396–90335).

Appendix A

Standard Features

Data Storage

Built-in Electronic Disk:

Size:	220 K; dynamically allocated; available for method, report, calibration, sequence, signal data, and BASIC program storage
Backup Method:	0.47 F Super Capacitor
Sustaining Time:	Minimum: 5.8 hrs at +25 C; Typical: 150 hrs at +25 C

Expansion Card Electronic Disks:

Slot Type:	PCMCIA version 2.0
Number of Slots:	2 (1 Type I/II/III, 1 Type I/II)
Cards supported:	SRAM ROM Flash (ATA standard only, 5V programming) Magnetic Disk (ATA standard only)
Size:	Capacity of media, up to 400MB
File System:	LIF (Logical Interchange Format)
Volume Partitions:	16 maximum per card

Barcode characters two, three, and four determine the injection volume, calibration level, and number of injections. Because they must be coded and printed beforehand for the samples being analyzed, an on-demand barcode printer is highly recommended. Barcode characters five, six, seven, and eight have no effect on the analysis.

Calculations and Reporting

Maximum Retention Time	6900 minutes
Retention Time Resolution	0.001 min (0.06 sec)
Maximum Peak Storage Capacity	Approximately 1240 peaks
Detectable Peak Width Range	Approximately 0.3 sec to 10.0 min width at half height (typical depending on [PK WD] parameter)
Methods	Area%, Height%, Normalization, External Standard, External Standard%, Internal Standard, and Internal Standard%. All calculations can be based on areas or heights.
Multilevel Calibration	Up to 63 levels possible
Curve Fits Available	Single-point, point-to-point, linear regression (least squares), nonlinear (quadratic)
Reference Peaks	Multiple reference peaks possible
Retention Time Windows	Percent or absolute time

Printer/Plotter Characteristics

Printer Paper	8.5 in. x 11 in. sheets on roll or z-fold with 0.5 in. tractor margins.
Print Character Format	96 ASCII Characters (upper- and lowercase)
Printing Speed	150 characters/sec avg; bidirectional
Character Density	12 characters/in.
Plotting Sensitivity	Approx 63.7 $\mu\text{V}/\text{cm}$ at $\text{ATT } 2^{\wedge} = 0$ (analog)
Valid Plotting Range	Attenuation: $\text{ATT } 2^{\wedge} = -8$ to $+36$
With an Analog Input	1 mV full scale at $\text{ATT } 2^{\wedge} = 0$ 1 V full scale at $\text{ATT } 2^{\wedge} = 10$
Maximum Selectable Chart Speed	30 cm/min
Maximum Plotting Velocity	31.7 cm/sec
Plotting Acceleration	845 cm/sec ²

External Control and Data Communications

Rear Panel Connections	3, labelled: REMOTE, SAMPLE, and COMPUTER.
REMOTE (Remote Control)	Inputs: ■ START (TTL) ■ STOP (TTL) ■ READY (TTL) Outputs: ■ START—1-second relay contact closure between SO1 and SO2 (start oven 1 and start oven 2) ■ READY (TTL)—open collector
SAMPLE	Accepts TTL BCD (binary coded decimal) (Bottle Number Sense) signals; selectable high or low input levels; bottle numbers from 0 to 99.
RS-232 (Data Communications)	RS-232-C protocol with baud rates: 150, 300, 600, 1200, 2400, 4800, 9600, 19200.

EPRM-Based Programs

Postrun Baseline Drawing	Unlimited File Size
Automatic File Naming	Five-digit prefix, appended run number
Sequence Chaining	Unlimited number of methods
Postrun Program Scheduling	Up to 30 programs for realtime and buffered channels
Batch Reprocessing	Unlimited number of files

Specifications

Data Acquisition

Analog Input Circuitry:

Input signal voltage range	-10 mV to +1 V (for specified accuracy)
Maximum differential input	-10 V to + 10 V (with no damage to integrator)
Maximum common-mode voltage	± 100 V (relative to integrator chassis)
DC input impedance	Differential: 33 Mohms, typical 8 Mohms, minimum Common mode: 500 Mohms, minimum
Input noise	40 nV rms, typical (with input shorted) 150 nV rms, maximum (with input shorted)
Analog dynamic range	>140 dB, typical
Common mode rejection	140 dB minimum, dc to 100 Hz
Thermal drift (input shorted)	1 μ V per $^{\circ}$ C, typical (0 to 35 $^{\circ}$ C) 2 μ V per $^{\circ}$ C, typical (35 to 55 $^{\circ}$ C) 4 μ V per $^{\circ}$ C, maximum (0 to 35 $^{\circ}$ C) 8 μ V per $^{\circ}$ C, maximum (35 to 55 $^{\circ}$ C)

Analog/Digital Conversion:

Converter type	Continuously integrating dual slope, 100% area recovery
Area resolution	120 nV-sec per count ($\pm 3\%$)
Resolution	>24 bits @ 1 Hz typical
Conversion Rates	0.08 to 20 readings per second
Bandwidth	3 Hz
Differential nonlinearity	Monotonicity guaranteed
Integral nonlinearity	$\pm 0.02\%$ of Full Scale, maximum*

*Maximum deviation from a straight line connecting the 0.0V and 1.0V response values.

Note: Specifications apply after a 1 hour warm-up period at an ambient temperature of 20 $^{\circ}$ C to 30 $^{\circ}$ C.

Electrical:

Line Voltage Selections Provided	115 and 230 V ac
Line Voltage Tolerance	For either voltage: +15, -22%
Frequency Range	48 to 66 Hz
Power Consumption	50 VA maximum
Power Supply Fuse (not replaceable)	2A, 250VAC IEC 127 Type F (quick-acting) 5 × 20 mm

Physical Characteristics:

Height, Top to Bottom	4.92 in. (12.5 cm)
Width, Left to Right	13.8 in. (35.1 cm)
Depth, Front to Back (without paper)	14.7 in. (37.3 cm)
Weight	9.5 lb (4.31 kg) without paper loaded.
Mechanical Mounting	Benchtop installation on a hard, flat surface with 6-in. (14.7 cm) clearance in front, in back, and along both sides to allow for ample ventilation.

Environmental Conditions:

Average Heat Dissipation	less than 120 Btu/hr
Temperature Range (operating)	5°C to +40°C
Temperature Range (storage)	-20°C to +60°C
Humidity Range (operating)	10% to 90% (noncondensing)

Appendix B

Storing Your Integrator

Choose a clean environment not exceeding:

- 95% relative humidity.
- 25,000 feet above sea level in altitude.
- +60°C or below -20°C (-4° to +140°F),

If the printhead is not in front of the blotter,

- Make sure that the power is OFF.
- Manually move the carriage to this position.

When storage temperature will exceed +50°C, remove the print cartridge and store it in a normal room temperature environment (+25°C).

When removing the unit from storage after

- Less than 6 months, prime and clean the printhead. (See chapter 4 for printhead maintenance procedures.)
- 6 months or more, replace the printhead.

Appendix C

Dual Channel INET_CONTROL Commands

You can use the dual channel INET control commands to interrogate and control the Buffered INET board of the HP 5890 and HP 6890, even if you do not have the Dual Channel Applications Program. You access the command set with the OP() 6 dialog. Press **[OP()] [6] [ENTER]**. Enter the INET GC address at the prompt, then enter the command string.

Command String	Function	Response
! Bnnn	Define buffered signal bunch size on input to main buffer, where “n” = ascii decimal digit for the HP 5890, and “n” = 1, 2, 4, 10, 20, 40, 100, or 200 for the HP 6890. The actual size is 10^{-2} of the selected number.	“A” if OK; “N” if rejected
!I	Initialize buffer for store or read by integrator. Set buffer read and write pointers to the start of the buffer.	
!F	Begin/resume buffer filling (HP 5890 only).	“A” if OK; “N” if rejected
!H	Halt/suspend buffer filling (HP 5890 only).	“A” if OK; “N” if rejected
!Sn	For the HP 5890, define signal source for buffer to be SIGn (n=1,2). Overrides default choice. See Note. For the HP 6890, the buffered signal is the signal that is not live. If no live signal is selected, the buffered signal defaults to	“A” if OK; “N” if rejected

signal 1. The !S command can change the buffered signal to signal 2.

!R	Read a signal block; returns compressed signal block (< or = 118 bytes) (HP 5890 only)	“A{binary block}” sent in Hex Ascii. “N” = rejected.
!O	Returns buffer status	“A CCCCCC B ppp s PPP S” where: CCCCCC=#pts in bfr, B=C1 path blk’d status= 0/1, ppp=pkwd of data in buffer s=buffer data source=1 or 2, PPP=pkwd of next buffer, S=next buffer data source, N=rejected
!V	Returns model#, and dual channel firmware version.	“A 19242.00.03” “N” = rejected
!Cn	Disable/Enable active C1 production	“A” if OK; “N” if rejected where: n=0/1 to enable (if C1Px+)/disable C1 data
MVER	Returns MIO version number (HP 6890 only).	
SIG1 RANGE nn SIG2 RANGE nn	n=0–16; selects range (HP 6890 only).	“A” if accepted; “N” if rejected.

Note: !Sn is overwritten by the default buffer selection scheme.

Buffer Signal Assignment

The buffered analysis signal source selection (S1A) is updated either by:

- The default assignment scheme.
- The !Sn INET_CONTROL command (see pg. C-2) .

Default Assignment Scheme

The HP GC software selects the buffer signal source in the following way:

- If S1B is 2 (OFF), then S1A is 0 (CH0 -> Buffer).
- If S1B is 1 (CH1 -> Realtime), then S1A is 0 (CH0 -> Buffer).
- If S1B is 0 (CH0 -> Realtime), then S1A is 1 (CH1 -> Buffer).

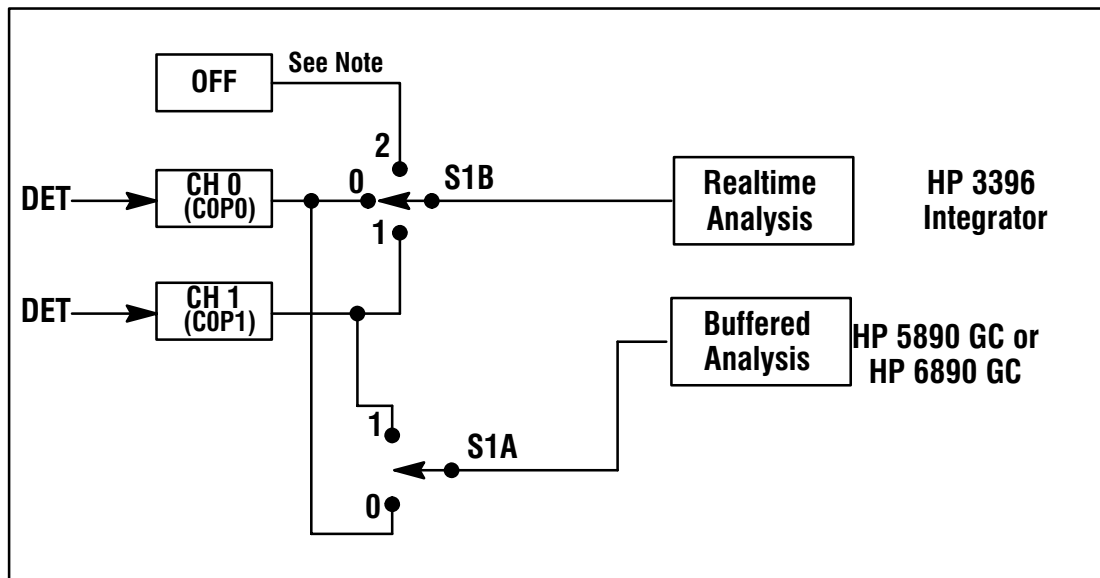

S1B can be operator defined using the 3396 INET_CONFIGURATION dialog. S1B is completely backed up.

The default buffer selection will be invoked by any of the operations listed below:

- A method is loaded.
- After a power fail recovery.
- After a loop break recovery.
- After an INET_CONFIGURATION command.

Each of these operations overrides the !Sn buffer signal selection.

Note: When S1B is set to OFF, the 3396 realtime signal source is the A/D converter.

Setting HP 3396 / HP GC Data Paths

The diagram on pages C-8 and C-9 represents a dual channel system consisting of the following components:

HP 18587 Barcode Reader

HP 7673 Automatic Sampler

HP 6890 or HP 5890 Gas Chromatograph (with INET buffered interface)

HP 3396 Integrator

This diagram illustrates how the data paths of a Dual Channel system can be controlled by various user inputs.

This page intentionally blank

Appendix A
title:1

```

* LIST: SEQ 8 @

7673A SAMPLER:
LOOP ADDRESS: 8

FRONT INJECTOR
...
...
PRIORITY SAMPLE (1=YES)
CAPILLARY ON-COLUMN      0

POSITION (1=FRONT, 2=REAR)
INET CHANNEL 1           1 → S3
INET CHANNEL 2           2 → A3
AUXILIARY CHANNEL       2 → B
    
```

```

* LIST: METH 9 @

HP 5890A GAS CHROMATOGRAPH
LOOP ADDRESS: 9

OVEN TEMP = 85   SETPT = 50 (OFF)
...
...
SIGNAL 1 = A → S2
INET FULL RANGE DATA ON → A
RANGE = 0
ZERO = 0.0
ATTN = 0

SIGNAL 2 = B → S2
INET FULL RANGE DATA ON → B
ZERO = 0.0
ATTN = 0
    
```

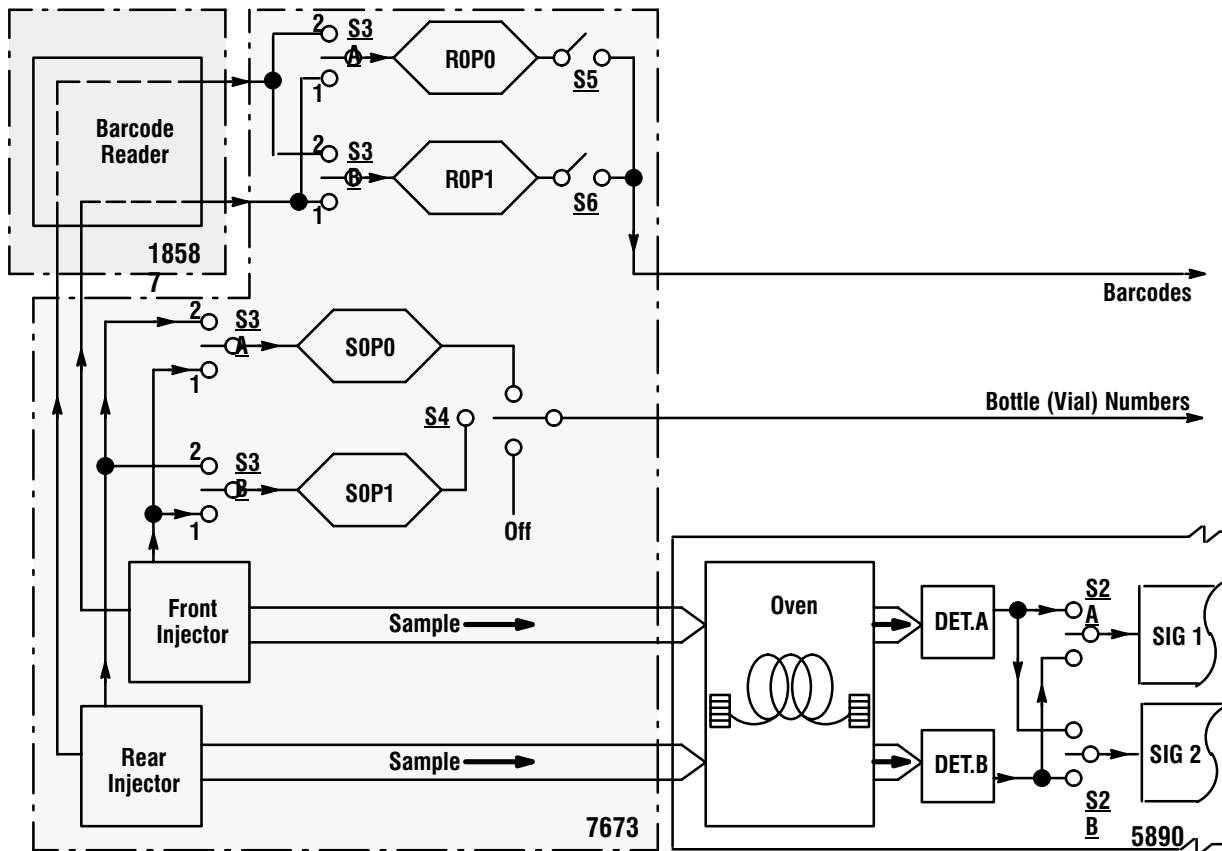

Appendix A
title:1

```

* OP # 6
REMOTE DEVICE ACCESS

DEVICE ADDRESS: 9
COMMAND STRING: !S1
A

DEVICE ADDRESS: 9
COMMAND STRING: !S2
A
    
```

} **S1
A**
See "default buffer
signal assignment"
on page C-4.

*IN						
INET CONFIGURATION						
ENTRY	MODEL	ADDR	DATA PATH		STATUS	
1	3396B	0	C1	CONS	CH 0	ACTIVE
2	5890A	9	C1	PROD	CH 0	ACTIVE
3	5890A	9	C1	PROD	CH 1	IDLE
4	3396B	0	K0	PROD	CH 0	ACTIVE
5	7673A	8	K0	CONS	CH 0	ACTIVE
6	5890A	9	K0	CONS	CH 0	ACTIVE
7	3396B	0	R0	CONS	CH 0	ACTIVE
8	7673A	8	R0	PROD	CH 0	ACTIVE
9	7673A	8	R0	PROD	CH 1	ACTIVE
10	3396B	0	S0	CONS	CH 0	ACTIVE
11	7673A	8	S0	PROD	CH 0	ACTIVE
12	7673A	8	S0	PROD	CH 1	IDLE

} **S1
B**

} **S5
S6**

} **S4**

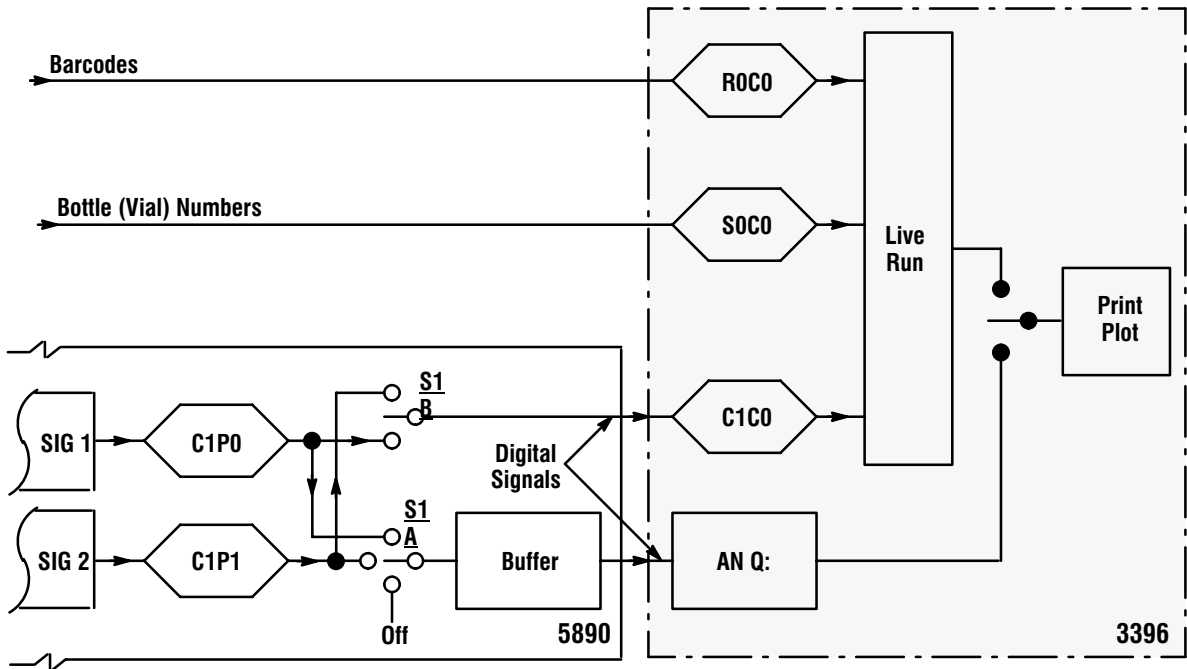

Index

A

- Addressing, HP-IL, 11–4
- Analog test, 7–15
- Applying power and running the self-test, 2–13
 - Initial turn on, 2–15
- Setting paper parameters, 2–17
- Setting the date and time, 2–19
- Verifying the voltage setting, 2–14

B

- Buffer signal assignment, C–3
 - Default assignment scheme, C–3

C

- Cable diagrams, 8–5
 - Analog signal cables, 8–5
 - Remote control cables, 8–8
 - RS-232-C cables, 8–21
 - Sample number cable, 8–18
- Cables for obsolete HP instruments, 8–4
- Calculations and reporting, A–2
- Changing the RS-232 settings with the SSET RS232 command, 12–10
 - Changing the default RS-232 configuration switches, 12–10

- Data rate switches 1, 2, 3, 12–12
- Handshake delay switch 9, 12–14
- Hardware handshake switch 4, 12–13
- Listing the switch settings, 12–12
- Switches 5, 6, 7, and 8 are not used, 12–14
- The RS-232 configuration switches, 12–10
- Timeout duration switch 10, 12–14

- Checking for instrument readiness, 10–5
- Choosing the proper cable, 12–4
 - Customizing cables, 12–7
 - DTE or DCE?, 12–5
- Compatible disk drives, 11–2
 - Autoconfiguration and reconfiguration, 11–4
 - Listing devices on the loop, 11–3
- Connecting HP-IL devices, 3–2
 - Installing an HP-IB disk drive, 3–7
 - Installing HP-IL and INET devices, 3–5
 - Installing the HP 19405B INTEG event control module (IECM), 3–6
 - Loop power-up, 3–8

- Connecting RS-232-C cables, 3–17
- Connecting the cable, 12–8
- Controlling INET instruments with the HP 3396, 10–9
 - Controlling the HP 5890 through BASIC, 10–13
 - Controlling the HP 7673 through BASIC, 10–14
- Controlling the HP 6890, 10–16

D

- Data acquisition, A–5
 - Electrical, A–6
 - Environmental conditions, A–6
 - Physical characteristics, A–6
- Data storage, A–1
- Description of self-test diagnostics, 7–6
 - 8051 interface tests, 7–6
 - 8051 ROM and RAM Tests, 7–6
 - A/D noise test, 7–7
 - Enable demo chromatogram, 7–11
 - Extended RAM test, 7–6
 - High-speed printer, 7–9
 - HP-IL/INET port & bus test, 7–7
 - Keyboard test, 7–9

-
- P/P ROM and RAM test, 7–10
 - P/P test, 7–8
 - PCMCIA socket test, 7–7
 - Quick RAM test, 7–6
 - Remote control and sample number input, 7–7
 - ROM CRC and bank select test, 7–6
 - RS-232-C port test, 7–6
 - Run all tests, 7–11
 - Diagnostic procedures, 7–19
 - Interpreting diagnostic test failures, 7–30
 - Measuring dc supply voltages, 7–19
 - Measuring motor windings, 7–23
 - Module level troubleshooting, 7–25
 - Partitioning failures, 7–25
 - Remote and sample number test, 7–31
 - RS-232-C cable testing, 7–32
 - Disassembly and reassembly instructions, 7–34
 - Remove power from the unit, 7–34
 - Remove the cooling fan, 7–40
 - Remove the keyboard, 7–35
 - Remove the line module, 7–40
 - Remove the main board, 7–41
 - Remove the paper, 7–34
 - Remove the paper hangers, 7–34
 - Remove the paper separator, 7–35
 - Remove the power supply board, 7–39
 - Remove the print mechanism, 7–37
 - Remove the printer window, 7–35
 - Remove the top cover, 7–35
 - Dual channel
 - INET_CONTROL commands, C–1
 - E**
 - EPROM-based programs, A–4
 - expansion cards, 2–20
 - Exterior cleaning, 4–2
 - External control and data communications, A–4
 - F**
 - Filling out the repair information form, 5–2
 - H**
 - HP service, 5–7
 - I**
 - Installing expansion cards, 2–20
 - Installing paper assemblies, 2–4
 - Installing the paper separator, 2–7
 - Installing the roll paper mechanism, 2–4
 - Installing the Z-fold paper mechanism, 2–6
 - Installing print cartridges, 2–8
 - Inserting the print cartridge, 2–11
 - Installing RS-232-C devices, 12–3
 - Installing sample/remote devices, 3–12
 - Connecting a remote control cable to Hewlett-Packard equipment, 3–14
 - Connecting a remote control cable to non-Hewlett-Packard units, 3–14
 - Installing the sample number (BCD) cable, 3–13
 - Installing signal cables, 3–9
 - Connections to Hewlett-Packard analytical instruments, 3–10
 - Connections to non-Hewlett-Packard analytical instruments, 3–11

Index

-
- Installing the prinng cartridges,
Priming the print cartridge, 2–10
- Installing the print cartridges,
Installing the blotter pad, 2–9
- L**
- Listing INET devices, 10–6
- Loading paper, 2–12
- M**
- Maintaining the printer, 4–5
- Checking the print cartridge, 4–6
- Cleaning the carriage contacts, 4–7
- Replacing the blotter pad, 4–5
- Matching RS-232-C protocol, 12–15
- O**
- One-volt input test, 7–18
- P**
- Power cable, 8–24
- Power Problems, COMM Indicator Light Blinks After Initial Turn On Tests Are Complete, 6–4
- Power problems, 6–2
- “Power failed” messages appear after working, 6–4
- Checking the fuse, 6–3
- No response at initial turn on, 6–2
- Printer/plotter characteristics, A–3
- Purpose of this section, 7–2
- R**
- RECONFIGURE command, how used. *See* System reconfiguration
- Recording important numbers, 1–4
- Removing/reloading paper, 4–3
- Reloading paper, 4–3
- Removing paper from the printer, 4–3
- Repacking your unit for shipment, 5–6
- Replacement parts, 8–2
- Returning your HP 3396 for repair, 5–5
- Running the automatic power-on tests, 6–14
- Running the self-test diagnostics, 7–3
- Running the signal tests, 7–15
- S**
- Safety information, 7–2
- Setting HP 3396/HP GC data paths, C–5
- Signal problems, 6–5
- Data represents a zero or signal baseline, or is pinned at maximum value with analog signal, 6–6
- Data represents a zero or straight baseline with INET instruments, 6–5
- Excessive noise or drift on chromatogram, 6–7
- Reported, processed, or raw data are not what you expected, 6–8
- Site requirements, 1–2
- SSET ANALOG, 7–15
- SSET RS232, 12–11
- Starting and stopping INET, 10–3
- Storing your integrator, B–1
- Symptom, 7–26
- LEDs do not light at power-on, 7–26
- LEDs remain on continuously after power-on, 7–27
- Paper does not feed or feeds slowly, 7–29
- Print carriage does not move or it chatters, 7–28
- System problems, 6–9
- “LOOP DOWN” message printed, 6–12

-
- External sample number is missing or inaccurate, 6–13
- HP 3396 does not communicate with RS-232-C device, 6–11
- HP 3396 does not start or stop an external device, 6–10
- Integrator cannot be started or stopped from an external device, 6–9
- System reconfiguration, automatic, 11–5
- T**
- The RS-232 configuration settings, 12–9
- U**
- Understanding HP-IL and HP-IB, 11–12
- How HP-IL operates, 11–13
- Understanding INET, 10–17
- Automatic network configuration, 10–21
- B0 data, 10–33
- Changing the INET configuration table, 10–29
- Chromatographic data, 10–34
- Controlling INET devices, 10–18
- Device dependent commands, 10–36
- Establishing and changing INET data paths, 10–24
- HP 3396 background tasks, 10–38
- Immediate data, 10–34
- INET data types, 10–24
- INET Operating States
- Inactive, 10–20
 - Postrun, 10–21
 - Prerun, 10–20
 - Run, 10–21
- INET operating states, 10–20
- Run and report annotation data, 10–32
- Sample data, 10–36
- Unpacking and inspecting your unit, 1–3
- Using disk drives, 11–7
- Accessing disk drives, 11–7
 - File system commands, 11–9
- Using external BASIC, 12–17
- Using non-INET analytical instruments, 9–3
- Using the remote control cable, 9–3
 - Using the sample number cable, 9–4
- Using RS-232-C in remote mode, 12–18
- V**
- Voltage test, 7–15
- W**
- What devices communicate with the integrator?, 9–2
- What is the instrument network?, 10–2
- What is the RS-232-C interface?, 12–2
- Z**
- Zero-volt input test, 7–17



Agilent Technologies

© Agilent Technologies, Inc.

08/97

Part Number

03396-90550